









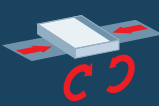

Transfer system

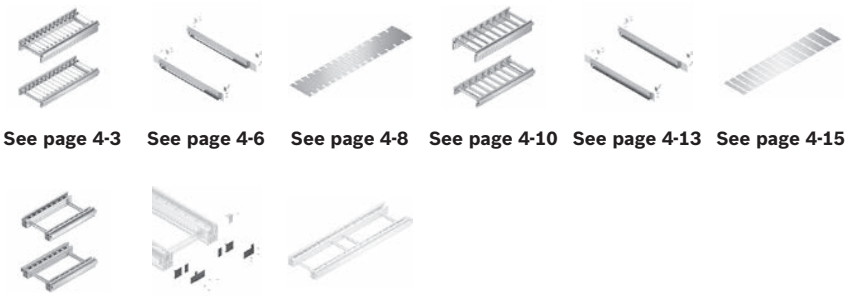
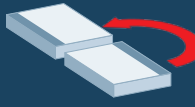
TS 5

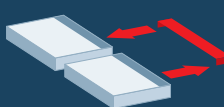
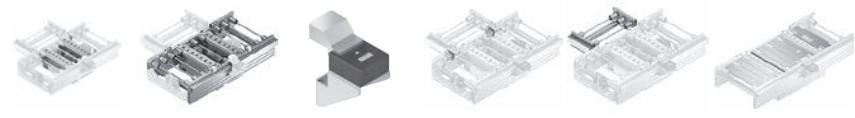
5.0

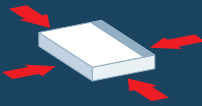
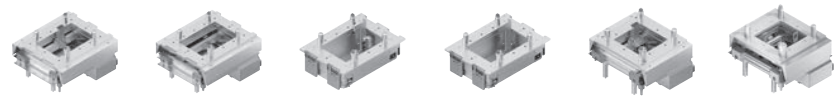
System overview TS 5

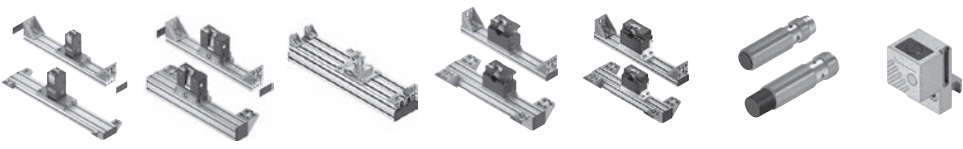
<p>Workpiece pallets</p> 	 <p>See page 2-4 See page 2-6 See page 2-10 See page 2-12</p>
<p>Drive unit</p> 	 <p>See page 3-4 See page 3-9 See page 3-14 See page 3-21 See page 3-28 See page 3-31</p>
<p>Longitudinal conveyor</p> 	 <p>See page 4-3 See page 4-6 See page 4-8 See page 4-10 See page 4-13 See page 4-15</p> <p>See page 4-17 See page 4-20 See page 4-22</p>
<p>Curves</p> 	 <p>See page 5-4 See page 5-8 See page 5-13 See page 5-18 See page 5-23 See page 5-27 See page 5-31</p>
<p>Transverse conveyor</p> 	 <p>See page 6-4 See page 6-7 See page 6-14 See page 6-16 See page 6-18 See page 6-20</p>
<p>Leg sets</p> 	 <p>See page 7-4 See page 7-6 See page 7-8</p>
<p>Positioning and orientation</p> 	 <p>See page 8-3 See page 8-6 See page 8-9 See page 8-12 See page 8-15 See page 8-18</p>
<p>Transportation control</p> 	 <p>See page 9-3 See page 9-6 See page 9-9 See page 9-12 See page 9-15 See page 9-19 See page 9-22</p>

Parameter

AO	Installation location
AT	Motor connection: K: with terminal box; S: with cable/plug
b	Track width
b_L	Track width in direction of transport (longitudinal conveyor)
b_Q	Track width in direction of transport (transverse conveyor)
b_{WT}	Width of workpiece pallet
BG	Bevel wheel material: 1: Plastic; 2: Sintered metal
CT	Protective cover: 0: without protective cover, 1: with protective cover
DD	Drive for drive module (OC): 1: on one side with 1 gear motor; 2: on two sides with 1 gear motor; 3: on two sides with 2 gear motors Drive for conveyor units (OC): 1: on one side; 2: on two sides Diverter direction: 1: left, 2: right
DP	Drive position / drive position, left (only for Open Center drive unit) / drive position, right (only for Open Center drive unit)
DSM	King shaft installation on main section: 1: left, 2: right
DST	King shaft installation on secondary section: 1: left, 2: right
f/U	Frequency/voltage
GM	Gear motor: 0: without (interface SW27); 1: with gear motor SW27; 2: without (interface to SEW connection, round shaft Ø20)
H	Transportation height
JD	Junction direction: 1: left, 2: right
KR	Curve direction: 1: left, 2: right
l	Length graduated according to the roller dimensions $l = p \times N$ (stored default values)
l_T	Length in direction of transport
l_{WT}	Length of workpiece pallet
LG	Lateral guide material: 1: Steel; 2: Plastic; 3: Aluminum
MA	Motor mounting: L: left; R: right
MT	Condition on delivery: 0: assembled; 1: not assembled
N	Number of rollers
OFD	Direction of the outfeed: 1: left; 2: right; 3: to both sides
p	Roller spacing (pitch): 130 mm; 195 mm; 260 mm; 325 mm
SC	Protective cover: 1: without protective cover; 2: with protective cover
TR	Roller material: 1: Steel, galvanized; 2: Steel, nitrocarburized
v_N	Nominal speed (m/min)

Symbols



Profile slot width (for attachments to profile slot)

...	Material number	Indicate the desired parameters on the order
...	3 842 998 786	
	b = ... mm	
	l = ... mm	
	SC = ...	

Ordering information

Explanation

Packing unit = minimum order quantity (📦 : here 20 units)

Example: Packing unit contains 20 units, material number 3 842 548 865, i.e. the order quantity must at least equal the specified quantity or a multiple of it; differing quantities will be rounded up.

Order examples:

Order 1x 3 842 548 865 = delivery 1x minimum order quantity 3 842 548 865 = 20 items

Order 35x 3 842 548 865 = delivery 2x minimum order quantity 3 842 548 865 = 40 items

Transfer system TS 5	1
Workpiece pallets	2
Drive unit	3
Longitudinal conveyor	4
Curves/diverters/rotary units	5
Transverse conveyor	6
Leg sets	7
Positioning and orientation	8
Transportation control	9
Identification systems	10
Tools	11
MTpro planning software	12
Technical data	13
Material number overview	14
Index	15





Transfer system TS 5

1

TS 5 – a premier-class roller conveyor	1-2
Operating principle	1-3
TS 5 features	1-5
Ambient conditions	1-6
Energy efficiency – Rexroth 4EE	1-9
Explanation of parameters b and l_r	1-10
Layout design – selection of modular units	1-11



TS 5 – a premier-class roller conveyor

The transfer system TS 5 transports loads of up to 400 kg and more. For planning and realization, a comprehensive modular system is available: drive modules, workpiece pallets, roller sections, curves, diverters, lift transverse units, positioning units and components for transportation control. Everything is designed for modular flexibility and pre-assembled and can be combined as needed using a single interface.

Driven by high-quality technology: the king shaft

The transfer system TS 5 with king shaft offers you considerable advantages compared to the usual chain drives:

- ▶ Low maintenance
- ▶ Noise-free operation
- ▶ High energy efficiency through effective performance with low drive power requirements
- ▶ Friction can be adjusted by hand
(after removing the protective cover on the king shaft)

New possibilities in all directions

In contrast to a chain-driven conveyor system, the TS 5 with its king shaft installation can be used without any limitations. Its drive concept gives you a great amount of planning freedom. You can, for example, branch the system off to the right or to the left. This is very economical because no additional drive modules are needed in many system layouts.

Flexible planning, simple set-up, fast commissioning

As a system supplier for all areas of automation, we offer you an extensive, industrially manufactured modular product line-up. The new transfer system TS 5 is also based on a flexible system of modular components. As a Rexroth customer, this offers you many advantages, including the fact that you will be operating in a familiar environment right from the start of assembly – with everything proceeding quickly and smoothly. As the components for the TS 5 are included in our *MTpro* planning software, the parts list is generated automatically, which considerably simplifies the entire planning process.

A choice of transport types

Different products require different types of conveyor sections. Accordingly, you can choose whether to transport your goods on a workpiece pallet or directly on a continuous roller track.

Advantages at a glance

- ▶ Fast, cost-effective system planning and expansion: The conveyor section design allows branching in both directions. And because the assembly space required for the drive is lower than the conveyor height, you can choose to have the drive mounted on either side. As always, all components are available in the *MTpro* planning tool.
- ▶ Reliable construction and fast commissioning: Industrially manufactured modular system with standardized components, resulting in short delivery times.
- ▶ High availability of the system thanks to the low-maintenance drive concept of the king shaft. Advantage: No more need for lubrication and greasing.
- ▶ Sturdy construction: Suitable for particularly harsh production environments and heavy loads.
- ▶ Everything from a single source: Easy ordering thanks to compatibility with the entire *MT* program.

Operating principle

Choice of system

To ensure the most economical operation possible, an assembly line requires precise forward planning. Later conversions must be as simple and cost-effective to execute as possible in order to be able to respond to future market demand. The key factors when selecting a suitable transfer system are the weight and quality of the workpieces to be conveyed as well as the particular production environment.

The flexible modular transfer system TS 5 from Rexroth covers a very wide range of requirements: With the wide range of mutually compatible modular units and macro modules permit a large variety of layouts with manual and automatic processing stations to be created. Solutions for maximum positioning accuracy or for especially heavy workpieces can be implemented easily using standard components. The future-proof transfer system TS 5 are designed for high availability, even under the harshest conditions.

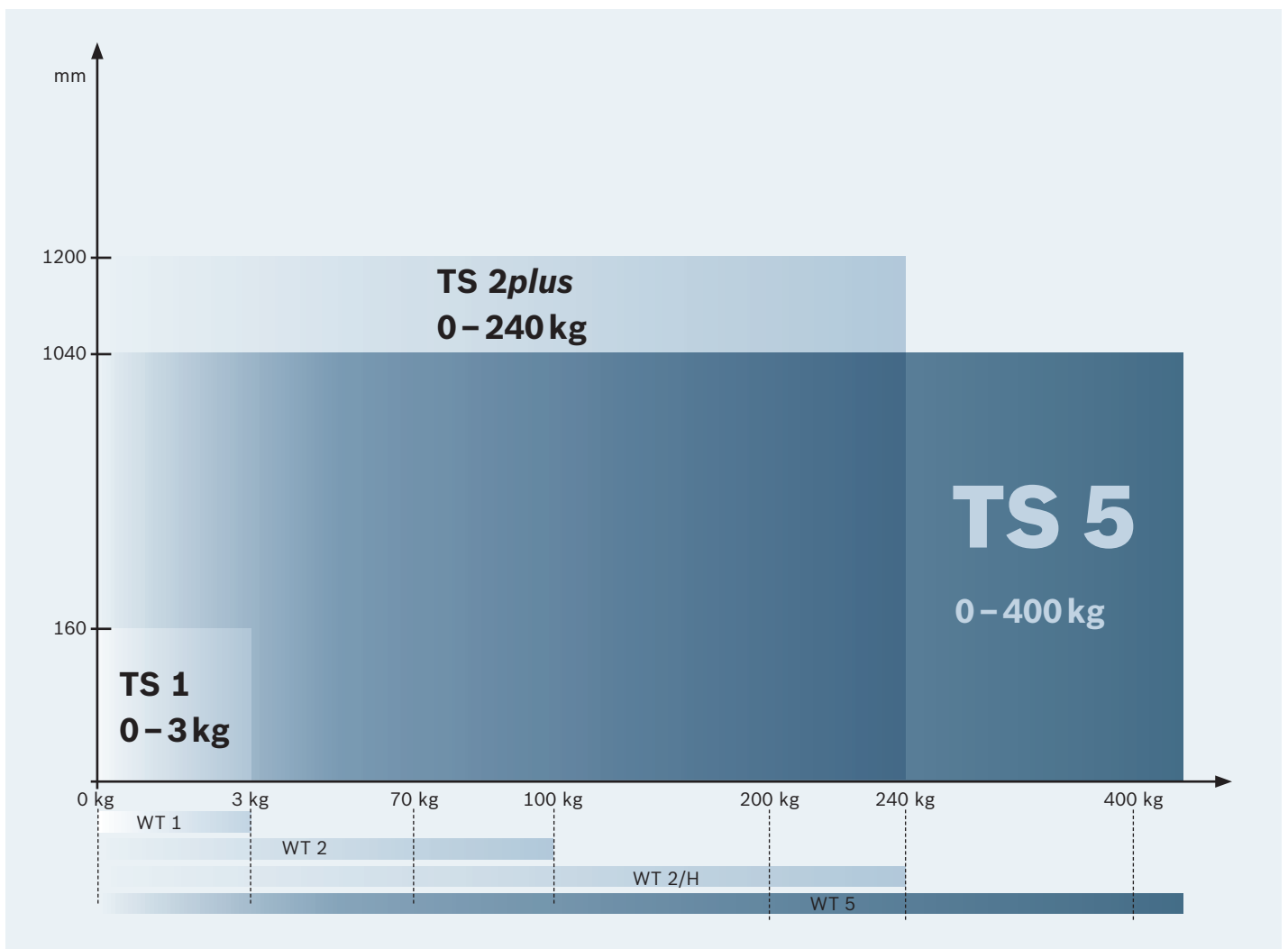

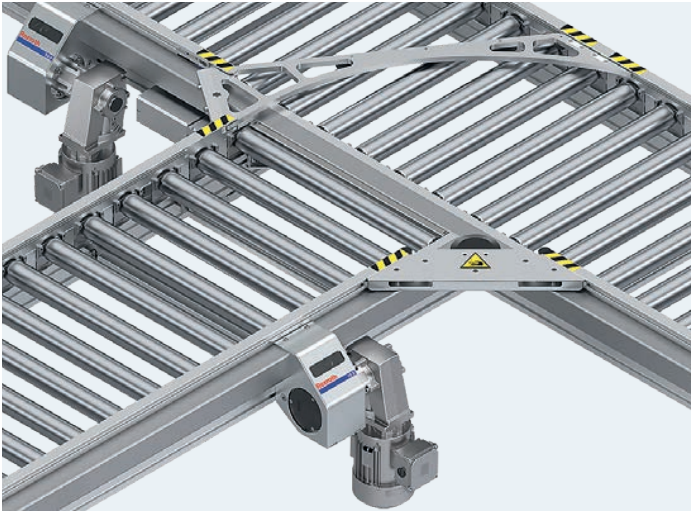

TS 5

TS 5 **0 – 400 kg**

The roller conveyor of the transfer system TS 5 conveys loads of up to 400 kg, over long distances where necessary, while its robust construction makes it especially suitable for harsh environments.

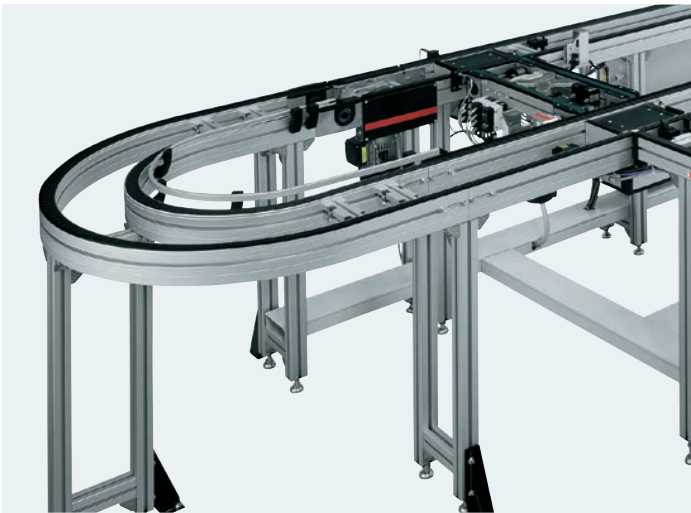

TS 2plus

TS 2plus **0 – 240 kg**

From the automotive industry and the electronics industry to household appliances and electronics manufacturing: With their diverse system components, TS 2plus assembly lines are suitable for use in a wide range of industries.

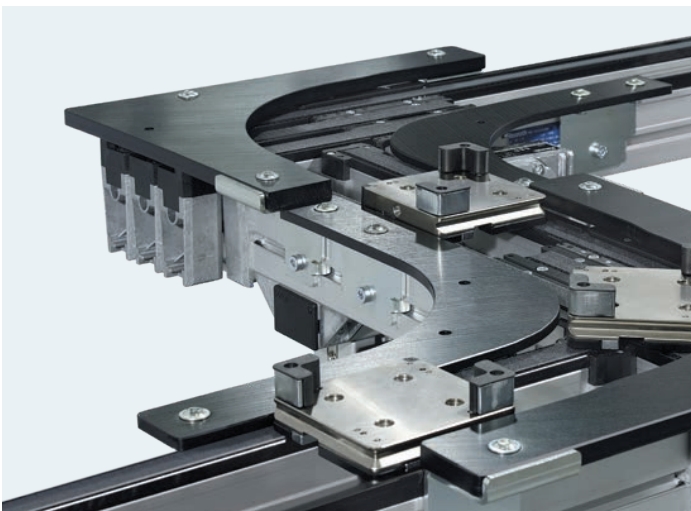

TS 1

TS 1 **0 – 3 kg**

The transfer system TS 1 is specifically tailored to small, lightweight products and assemblies, which require high positioning accuracy and repeatability.

TS 5 features

Selection data



Available workpiece pallet (WT) dimensions

Workpiece pallets with system widths of 455 ... 845 mm allow adjustment to the respective workpiece geometry as needed. If necessary, a number of workpieces can be accommodated on a single workpiece pallet (WT).

Permissible workpiece pallet (WT) weights

To ensure that the permissible surface pressure between the WT and conveyor medium is not exceeded, the WT total weight is limited for each WT size.

The WT total weight results from:

- ▶ Workpiece pallet weight
- ▶ WT load (workpiece, pick-up, etc.)
- ▶ Weight of the special equipment (data carrier, etc.)

For workpiece pallets that are not square, please note that the permissible WT total weight may be different for longitudinal conveyors and transverse conveyors.

On request, the largest workpiece pallet in combination with Open Center sections can also be used for weights > 400 kg.

Ambient conditions

Materials used, media resistance

Rexroth transfer systems are manufactured with high-quality materials to ensure continuous use. They are resistant to lubricating and cleansing agents that are common in an industrial environment. However, we cannot guarantee that the products contained in this catalog are resistant to all combinations of testing liquids, gases, or solvents. Please contact your Rexroth representative if you have any doubts.



Environmental conditions – climatic

The transfer systems have been designed for stationary use in a location that is protected from the elements.

Operating temperature

+5 ... +40 °C
-5 ... +60 °C with 20%
less load

Storage temperature

-25 °C ... +70 °C

Relative humidity

5 ... 85%, non-condensing
1 ... 2% (dry room) on request

Air pressure

> 84 kPa as appropriate
Installation altitude < 1400 m above sea level.
Load values are reduced by 15% when the installation
altitude is over 1400 m above sea level.

Environmental conditions – biological

Avoid molds, fungi, rodents, and other vermin.

Environmental conditions – chemical

Do not set up near industrial systems with chemical
emissions.

Environmental conditions – physical

Do not set up in areas that are regularly jarred by high
forces caused by, e.g., presses, heavy machinery, etc.





Suitability for electrostatically sensitive areas

Almost all of the components and parts in Rexroth transfer systems are ESD-compatible or available in an ESD-compatible version. They can thus principally be used in EPA (ESD-protected areas). We do, however, recommend that you contact your Rexroth representative.

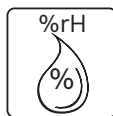

Use in dry rooms

TS 5 has been tested and approved with all conveyor media for use in dry rooms with a relative humidity of 1 ... 2%, e.g., for the production of Li-Ion battery cells. Your Rexroth representative will be pleased to advise you about this.



Use in oily environments

Almost all of the TS 5 components are suitable for use in oily environments. The transfer system has a high resistance to many oils commonly found in manufacturing. In case of doubt regarding resistance to test oils and doped oils, we recommend you contact your Rexroth specialist.



Use in clean rooms

Almost all the components have been approved by the IPA^{*)} for use in cleanrooms and for cleanroom class 8 according to DIN EN ISO 14644-1. Please note that some cleanroom-compatible components have been specially modified. Please contact your Rexroth representative if you require cleanroom components.

^{*)} Fraunhofer Institute for Manufacturing Engineering and Automation, Stuttgart, Germany

Energy efficiency – Rexroth 4EE

4EE
ENERGY
EFFICIENCY

1

Energy efficiency is a key factor for corporate success

From an economic point of view, energy efficiency and reduced emissions lower operating costs and bring advantages in the fiercely competitive global market. In addition, they help support compliance with environmental standards.

All potentials for optimization are used effectively when not only the details of a system but the system as a whole is optimized. The 4EE system features four levers:

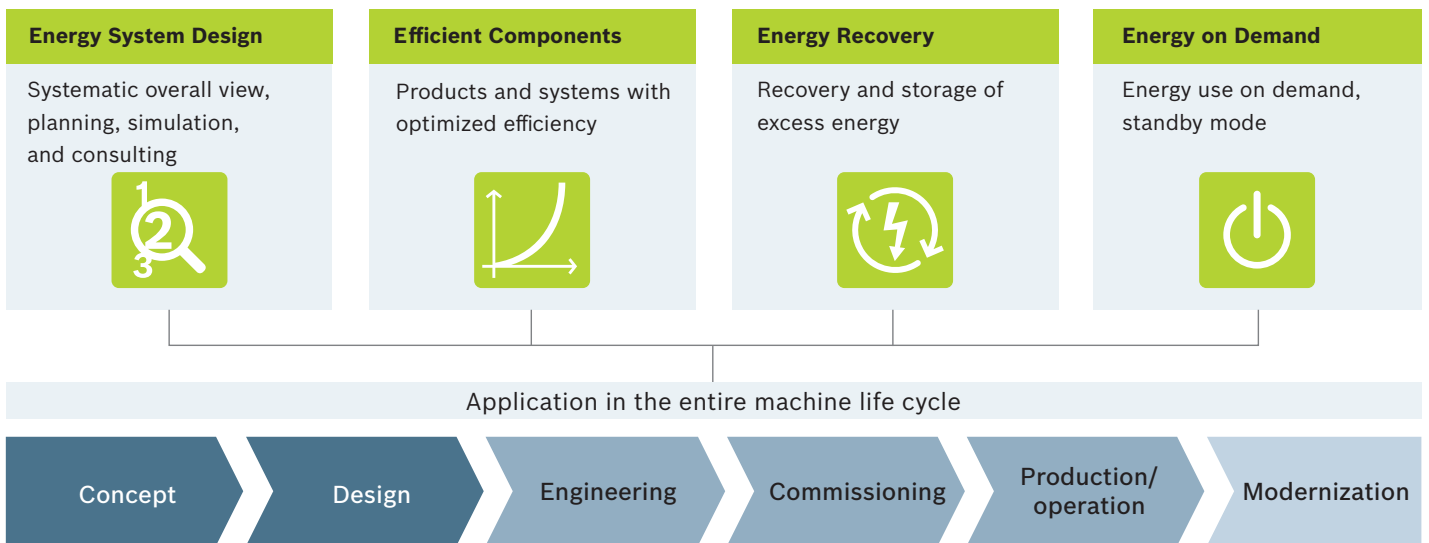

Efficient system layout

To achieve high energy efficiency, the system must be examined as a whole as early as in the planning phase. The TS 5 modular system offers numerous modules, all of which enable you to implement a transfer system tailored precisely to the particular application. This effectively prevents over-dimensioning and high energy losses from the outset.



Energy-efficient modules

The TS 5 modules are equipped with particularly energy-efficient drives. The efficiency of most of the motors already exceed future requirements. The interplay of friction-optimized materials, e.g., on sliding rails, friction-minimizing gear oils and numerous further design details ensures perfect coordination in the overall system.



Energy use on demand

Minimal energy consumption requires the ability to be able to switch off system components on demand. The majority of motors in the TS 5 are designed for start-stop operation and frequency converter operation.



Worldwide approval

For international use, most of the motors feature CE, cURus and CCC approvals.

Explanation of parameters b and l_T

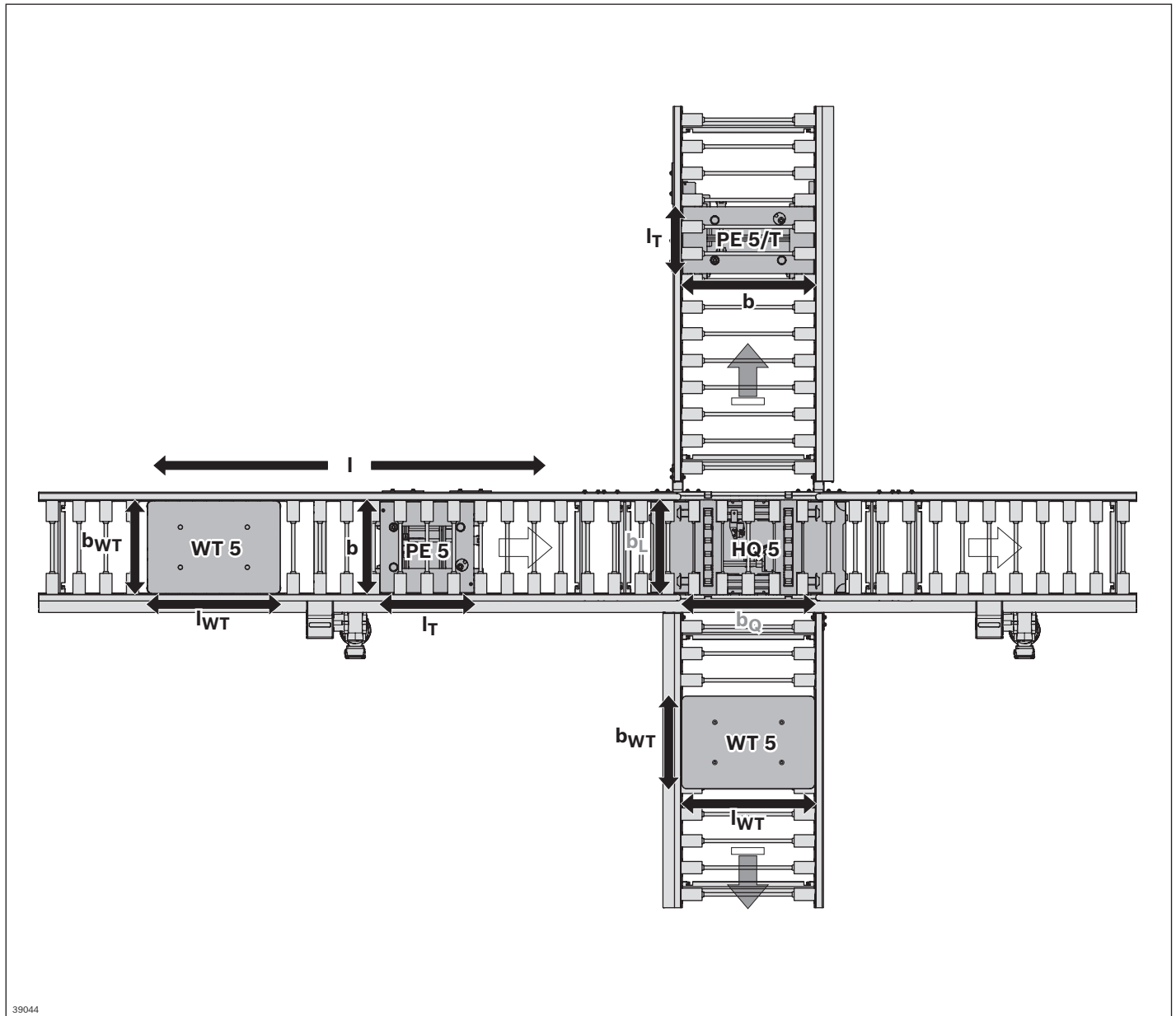

39044

Modular units	Width	Length
WT	b_{WT}	l_{WT}
AS	b	l
ST	b	l
CU/DI/JU/DE	b	l_T
HQ	b_L	b_Q
PE	b	l_T

- b_{WT} = Width of workpiece pallet
- l_{WT} = Length of workpiece pallet
- b = Track width
- l = Length graduated according to the roller dimensions
- l_T = Length in direction of transport
- b_L = Track width (longitudinal conveyor)
- b_Q = Track width (transverse conveyor)

Layout design – selection of modular units

Example: Using a rotary unit instead of a curve

Unlike curves, rotary units can also be used for loads of ≥ 300 kg. The height level on the entire concentricity is identical which means that there is no need to distinguish

between main and secondary section.

Concentricity with curves

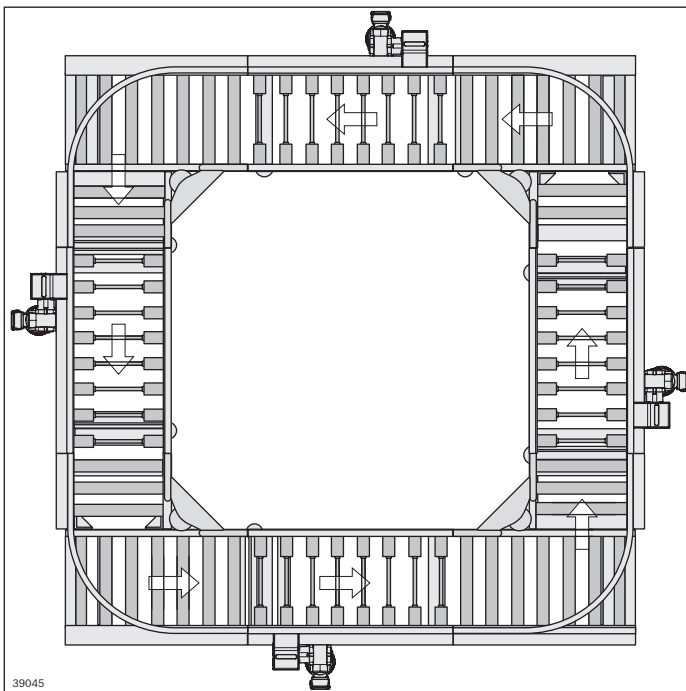

Concentricity with rotary units

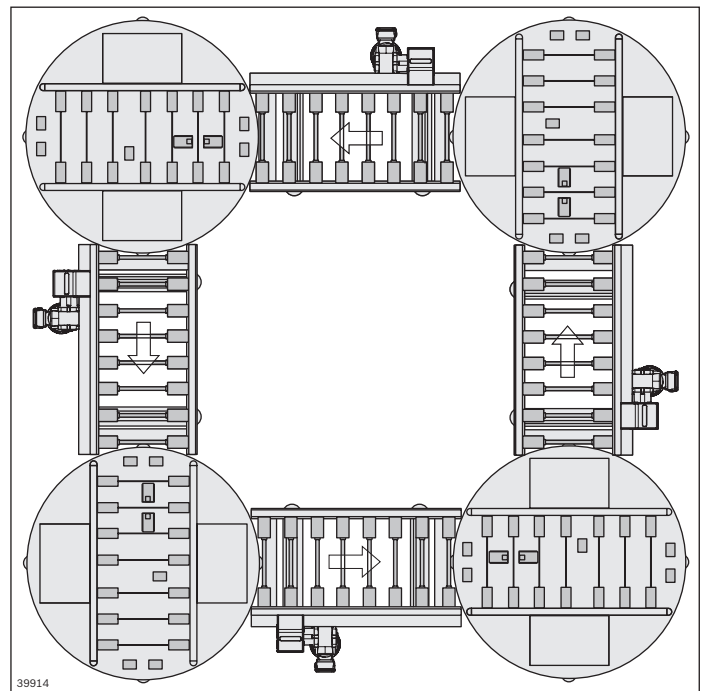

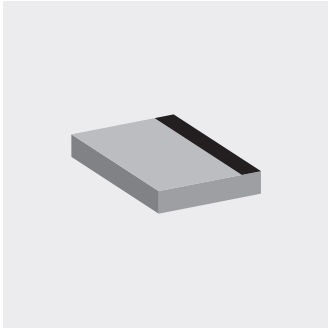

Workpiece pallets

2

Workpiece pallet selection	2-2
Base body	2-4
Accessories	2-6
Permissible workpiece pallet load	2-8
Selection of workpiece pallets in accordance with load limits	2-9
Carrying plates, standard sizes	2-10
Carrying plates, variable dimensions	2-12

Workpiece pallet selection

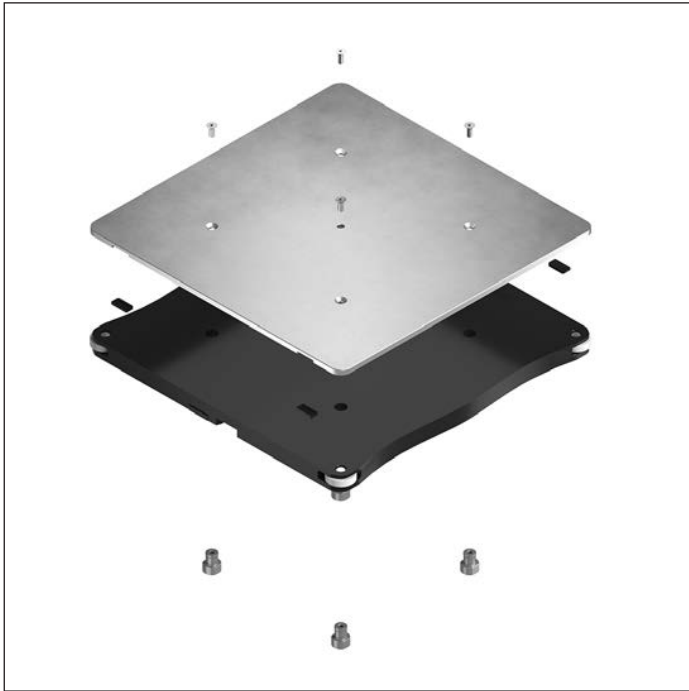

Versions

The workpiece pallet is a modular system consisting of a base body and carrying plate. The positioning bushings (see page 2-6) and an attachment kit (see page 2-6) comprising sensor plates, damping elements and rollers with pins are available separately.

- ▶ Workpiece pallets available in 6 standard sizes, see page 2-4
- ▶ Side rollers reduce friction, particularly in curves, diverters, and junctions
- ▶ Aluminum carrying plates available in 2 thicknesses (see page 2-10) and with variable dimensions (see page 2-12):
The carrying plate may extend over the front and rear of the base body

Application and functions

The workpiece pallet transports the workpiece in the transfer system as it goes through the processing stations.

- ▶ Defined positioning of the supported workpiece in the processing station is enabled through integrated positioning bushings.
- ▶ Integrated damping elements help to avoid noise and damage when workpiece pallets run into each other.
- ▶ Workpiece-related information can be transferred with the workpiece during processing using optional data tags. This information can be evaluated on-site and also updated.

The orientation of the workpiece pallet on the conveyor section must strictly be observed:

- ▶ Traveling through curves/diverters is only possible in a longitudinal conveyor direction (see arrow on workpiece pallet).
- ▶ Separating workpiece pallets is only possible in a longitudinal conveyor direction (see arrow on workpiece pallet). A WT can also be brought cleanly to a halt on the outside of a transverse conveyor.
- ▶ In order to read out data tags, the workpiece pallet must cross the reader in the proper position.

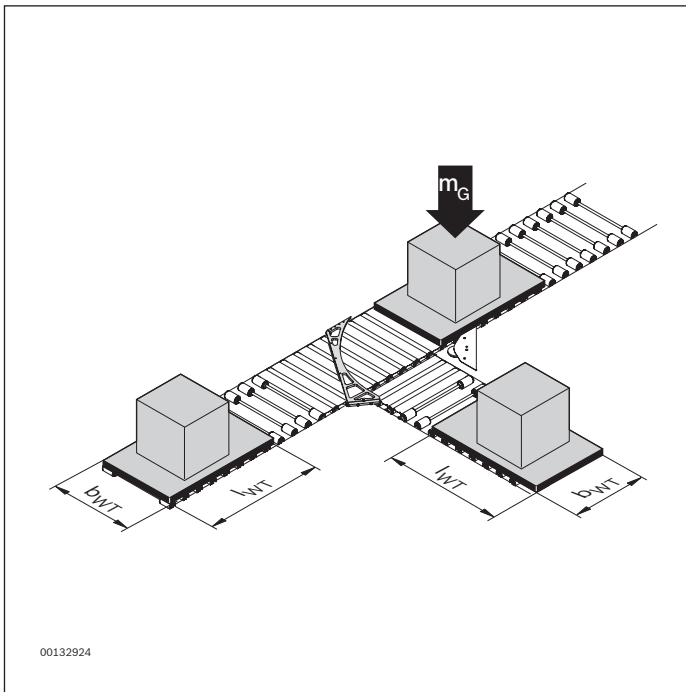

Size and load capacity

The total weight of a workpiece pallet m_G is the sum of the

- ▶ Base body weight
- ▶ Carrying plate weight
- ▶ Workpiece support weight
- ▶ Workpiece weight
- ▶ Identification system weight

Depending on the total weight m_G of the workpiece pallet, the transport system can be set up with various parameters:

- ▶ Roller spacing
- ▶ Load class of the conveyor unit

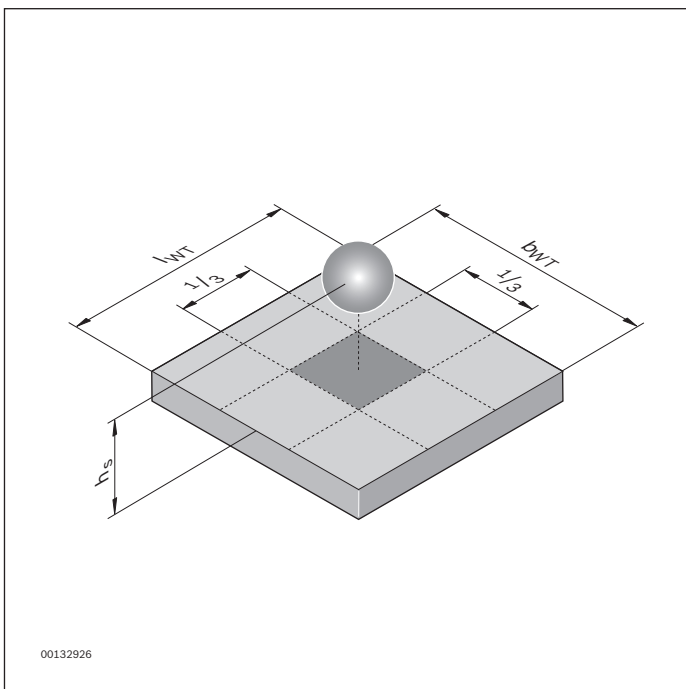

Permissible gravity center position

In order to absorb acceleration forces without any problems when separating and changing the direction of the pallets (in curves, when changing to transverse conveyors), the location of the load center of gravity on the workpiece pallet must be noted.

We generally recommend that:

- The load should be positioned in the center of the workpiece pallet.
- The load center of gravity should not exceed a height h_s of $1/3 b_{WT}$ (with $b_{WT} \leq l_{WT}$).

Limits with junctions and diverters, see pages 5-17 and 5-22

Base body

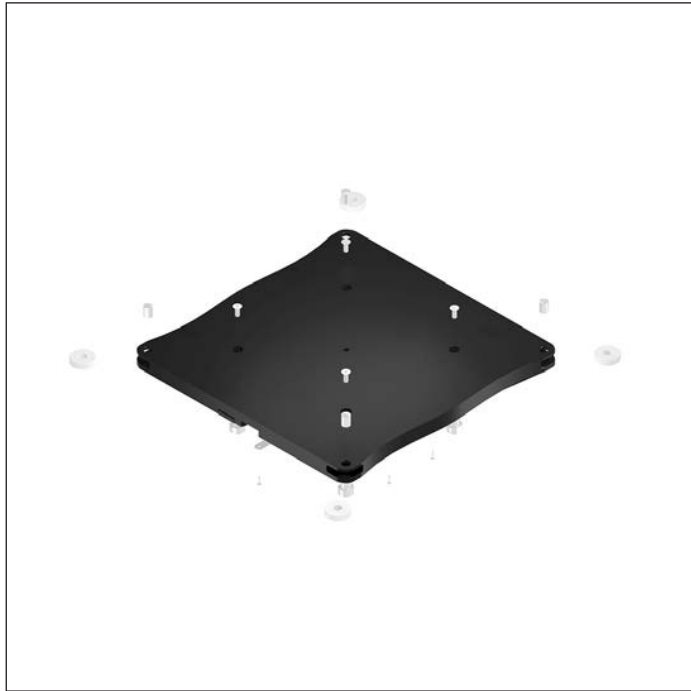

Condition on delivery

- ▶ Not assembled, attachment kit available, without carrying plate

Required accessories

- ▶ Attachment kit incl. rollers, roller pins, damping elements and sensor plates, see page 2-6

Ordering information

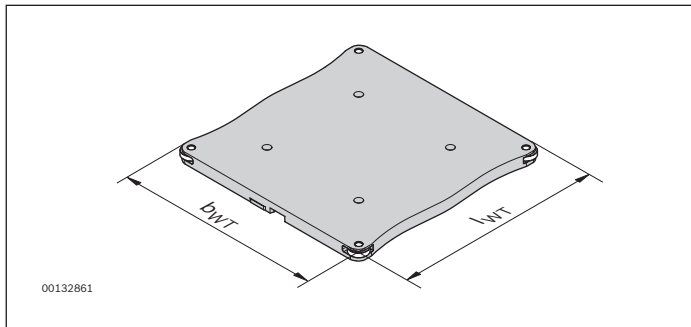

Use

- ▶ The base body is the interface between the transfer system and the carrying plate with workpiece fixtures
- ▶ The base body is designed to deal with the highest loads

Version

- ▶ 6 standard sizes
- ▶ Optimized contours for easier movement through curves
- ▶ Stop gate stop on interior and exterior of the workpiece pallet surface (in the longitudinal conveyor direction)
- ▶ Can be combined with mobile data tags from the ID 200 RFID system, see RFID systems catalog

Material

- ▶ PE UHMW, ESD-capable

Recommended accessories

- ▶ Positioning bushing set, see page 2-6
- ▶ Carrying plate, see page 2-10; 2-12

Product description	Material number
Base body WT 5, 455/455	3 842 545 080
Base body WT 5, 455/650	3 842 545 083
Base body WT 5, 650/650	3 842 545 086
Base body WT 5, 650/845	3 842 545 089
Base body WT 5, 845/845	3 842 545 092
Base body WT 5, 845/1040	3 842 545 095

Dimensions

Workpiece pallet WT 5

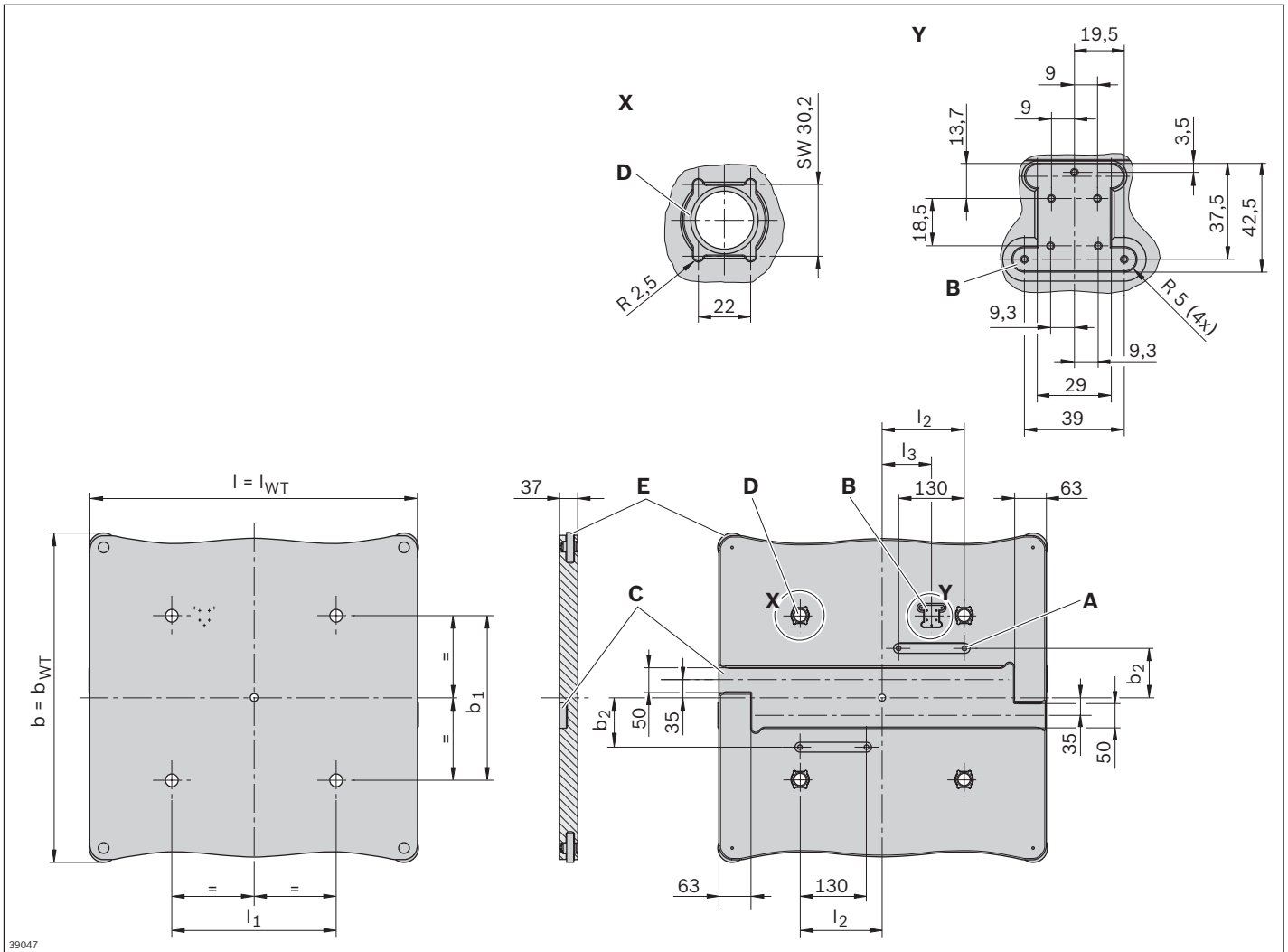

- A Damping element
- B Holder for ID 200 data tag
- C Stop gate feed-through
- D Mounting for positioning bushing
- E Guide rollers

3D models can be found in the eShop or in MTpro, see page 12-3

b_{WT} (mm)	l_{WT} (mm)	m_{WT} (kg)	b_1 (mm)	l_1 (mm)	l_2 (mm)	l_3 (mm)	b_2 (mm)
455	455	6.4	195	195	97.5	0	67.85
455	650	8.9	195	325	162.5	97.5	67.85
650	650	13.5	325	325	162.5	97.5	97.5
650	845	17.2	325	520	260	65	97.5
845	845	23.2	520	520	260	65	97.5
845	1040	27.2	520	715	357.5	162.5	97.5

m_{WT} = Weight of the workpiece pallet itself
Description of further parameters, see page 0-3

Accessories

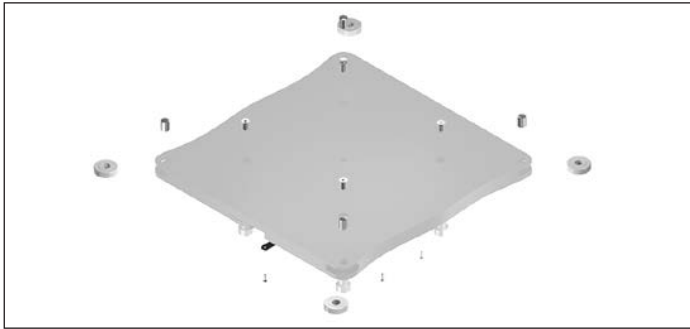

Attachment kit

Use

- ▶ Attachment kit for installation of the workpiece pallet

Version

- ▶ 4 rollers for lateral guides
- ▶ 4 roller pins for adjusting the rollers
- ▶ 2 sensor plates for damping inductive sensors
- ▶ 4 damping elements help to avoid noise and damage when workpiece pallets run into each other.

Material

- ▶ PUR, POM

Attachment kit

	b_{WT} (mm)	Material number
	455	3 842 554 931
	650; 845	3 842 554 932



Positioning bushing set

Use

- ▶ For fixing the carrying plate on the base body
- ▶ For a defined workpiece pallet entry in the positioning unit

Scope of delivery

- ▶ 4 positioning bushings, 4 screws for fixing the carrying plate

Material

- ▶ Hardened steel

Positioning bushing set

	Material number
Set	3 842 545 264

Dimensions

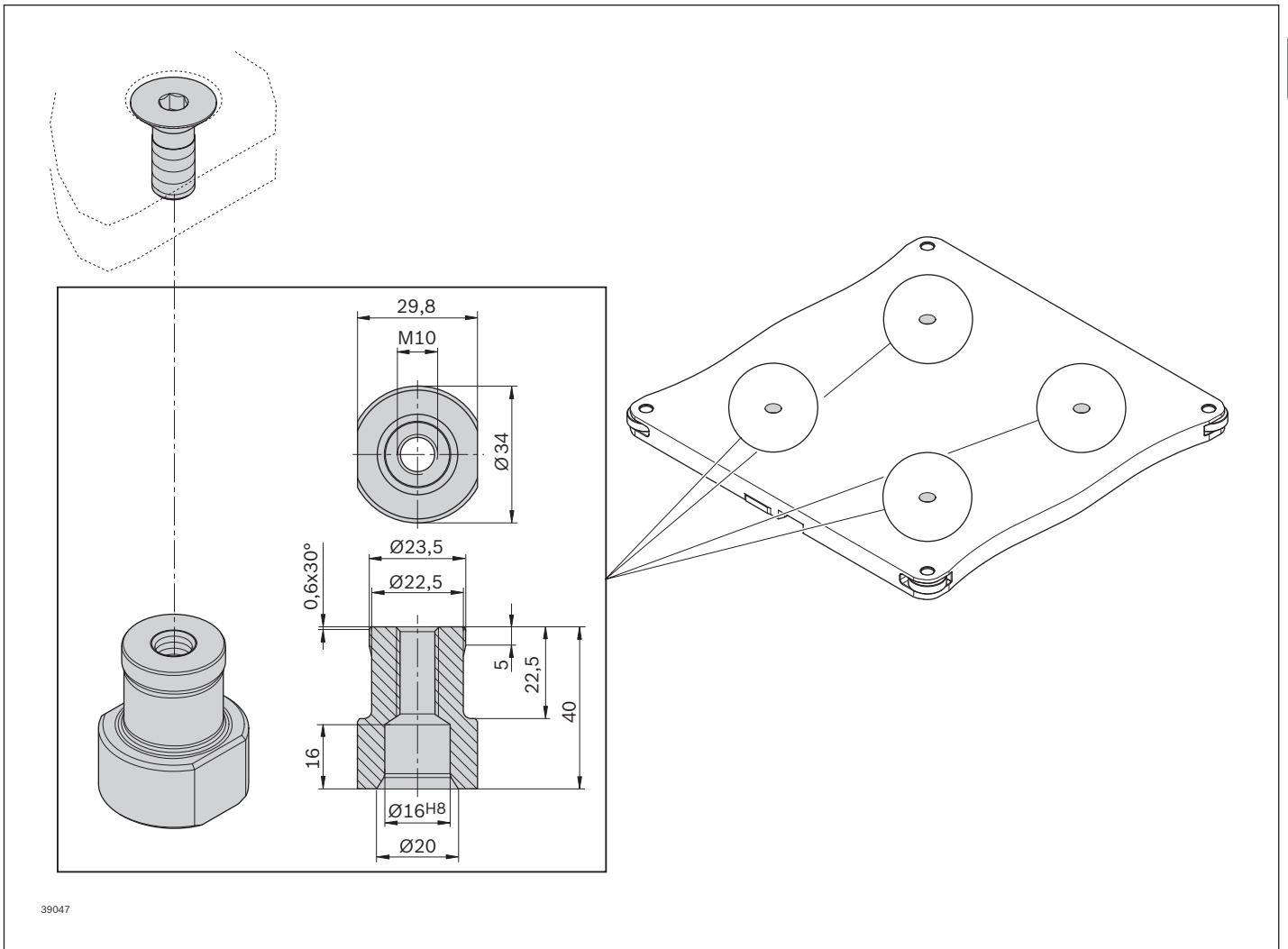

Permissible workpiece pallet load

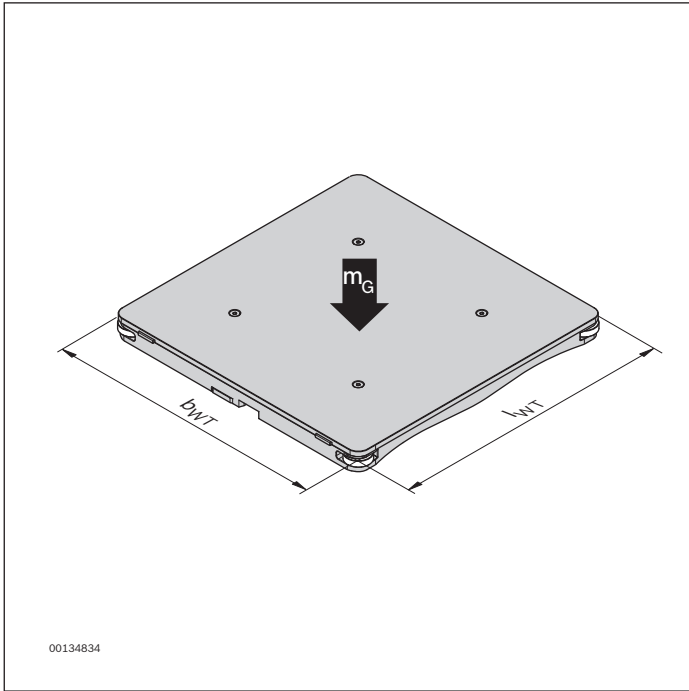

The permissible load from the conveyed goods is calculated based on the permissible WT total weight less the weight of the workpiece pallet itself including supports and special equipment etc.

The permissible total weight depends on the length of the workpiece pallet l_{WT} , and on the roller spacing.

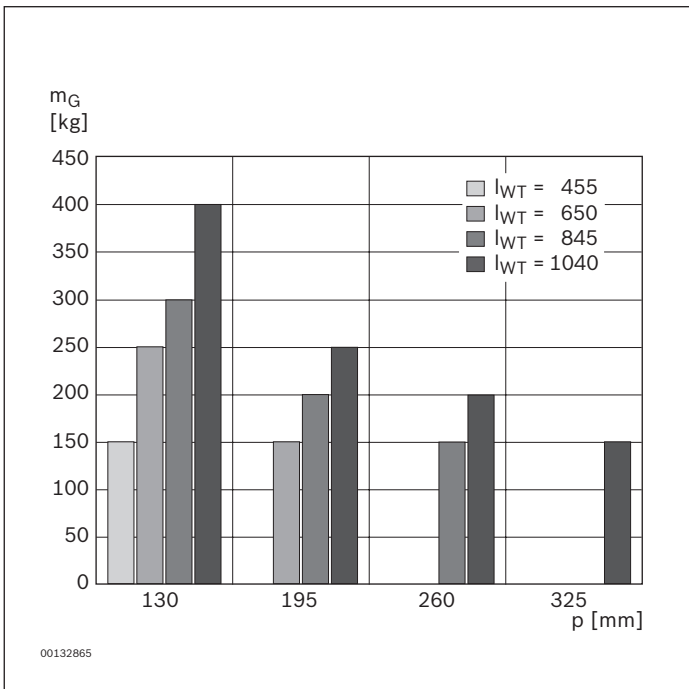

The carrying force per roller is 50 kg, and the WT must always be on at least 3 rollers. The resulting load limits for the longitudinal conveyor are illustrated in the graphic.

Notice: Alternative load limits must be observed for curves, junctions, diverters, lift transverse units, positioning units and rotary units, see page 13-5

Selection of workpiece pallets in accordance with load limits

For workpiece pallets that are not square, please note that the permissible WT total weight m_{Gzul} is different for longitudinal and transverse conveyors. In the transverse conveyor, the shorter side (b_{WT}) is to be used for the calculation.

The resulting permissible WT total weights are shown in the table opposite.

The WT total weight m_G results from:

- ▶ Workpiece pallet weight
- ▶ WT load (workpiece, support, etc.)
- ▶ Weight of the special equipment (data carrier, etc.)

The WT total weight m_G must not exceed the permissible WT total mass m_{Gzul} :

$$m_G \leq m_{Gzul}$$

The workpiece pallet must be designed with sufficient rigidity for the load. The deflection of the workpiece pallet (base body can be ignored) must not exceed 1 mm.

Permissible load according to the number of rollers

b_{WT} (mm)	l_{WT} (mm)	p (mm)	m_{Gzul}		m_{WT1} (kg)	m_{WT2} (kg)	m_{WT3} (kg)
			Longitudinal conveyor (kg)	Transverse conveyor (kg)			
455	455	130	150	150	13.6	17.4	6.7
455	650	130	250	150	18.8	24.3	8.9
455	650	195	150	–	18.8	24.3	8.9
650	650	130	250	250	28.8	35.3	13.9
650	650	195	150	150	28.8	35.3	13.9
650	845	130	300	250	36.3	45.5	17.7
650	845	195	200	150	36.3	45.5	17.7
650	845	260	150	–	36.3	45.5	17.7
845	845	130	300	300	48.0	60.0	23.8
845	845	195	200	200	48.0	60.0	23.8
845	845	260	150	150	48.0	60.0	23.8
845	1040	130	400	300	57.6	72.4	27.7
845	1040	195	250	200	57.6	72.4	27.7
845	1040	260	200	150	57.6	72.4	27.7
845	1040	325	150	–	57.6	72.4	27.7

- p = Roller spacing (pitch)
- m_{Gzul} = Permissible WT total weight
- m_{WT1} = Weight of workpiece pallet, fully installed with carrying plate (weight of base plate + weight of carrying plate $d_{pl} = 12.7$)
- m_{WT2} = Weight of workpiece pallet, fully installed with carrying plate (weight of base plate + weight of carrying plate $d_{pl} = 19.05$)
- m_{WT3} = Weight of workpiece pallet, fully installed without carrying plate (weight of base plate)

Carrying plates, standard sizes



Use

- ▶ For combination with a base body to form a workpiece pallet WT 5
- ▶ For finishing fixtures by the user

Version

- ▶ 6 standard sizes in 2 thicknesses
- ▶ Carrying plate, ready to assemble with mounting holes

Material

- ▶ Aluminum

Notice: To assemble the carrying plate on the base body:
Positioning bushing set 3 842 545 264, see page 2-6

Ordering information

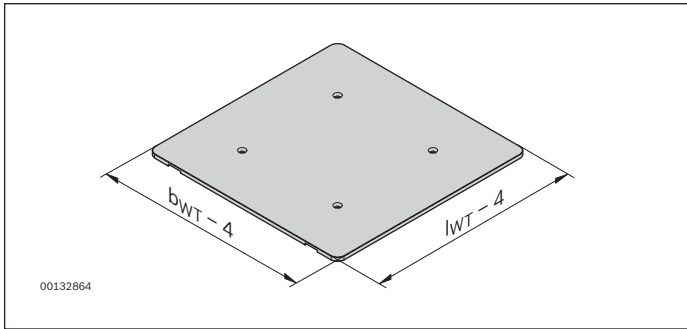

b_{WT} (mm)	l_{WT} (mm)	d_{PL} (mm)	□* (mm)	m_{PL} (kg)	Material number
455	455	12.7	0.6	6.6	3 842 545 081
455	650	12.7	0.8	9.4	3 842 545 084
650	650	12.7	0.8	14.2	3 842 545 087
650	845	12.7	1.0	18.6	3 842 545 090
845	845	12.7	1.0	24.2	3 842 545 093
845	1040	12.7	1.2	29.8	3 842 545 096
455	455	19.05	0.6	10.4	3 842 545 266
455	650	19.05	0.8	14.9	3 842 545 267
650	650	19.05	0.8	21.3	3 842 545 268
650	845	19.05	1.0	27.8	3 842 545 269
845	845	19.05	1.0	36.2	3 842 545 270
845	1040	19.05	1.2	44.6	3 842 545 271

b_{WT} = Width of workpiece pallet
l_{WT} = Length of workpiece pallet

d_{PL} = Plate thickness
□* = Evenness

m_{PL} = Plate weight

Dimensions

WT 5: Carrying plate, standard sizes

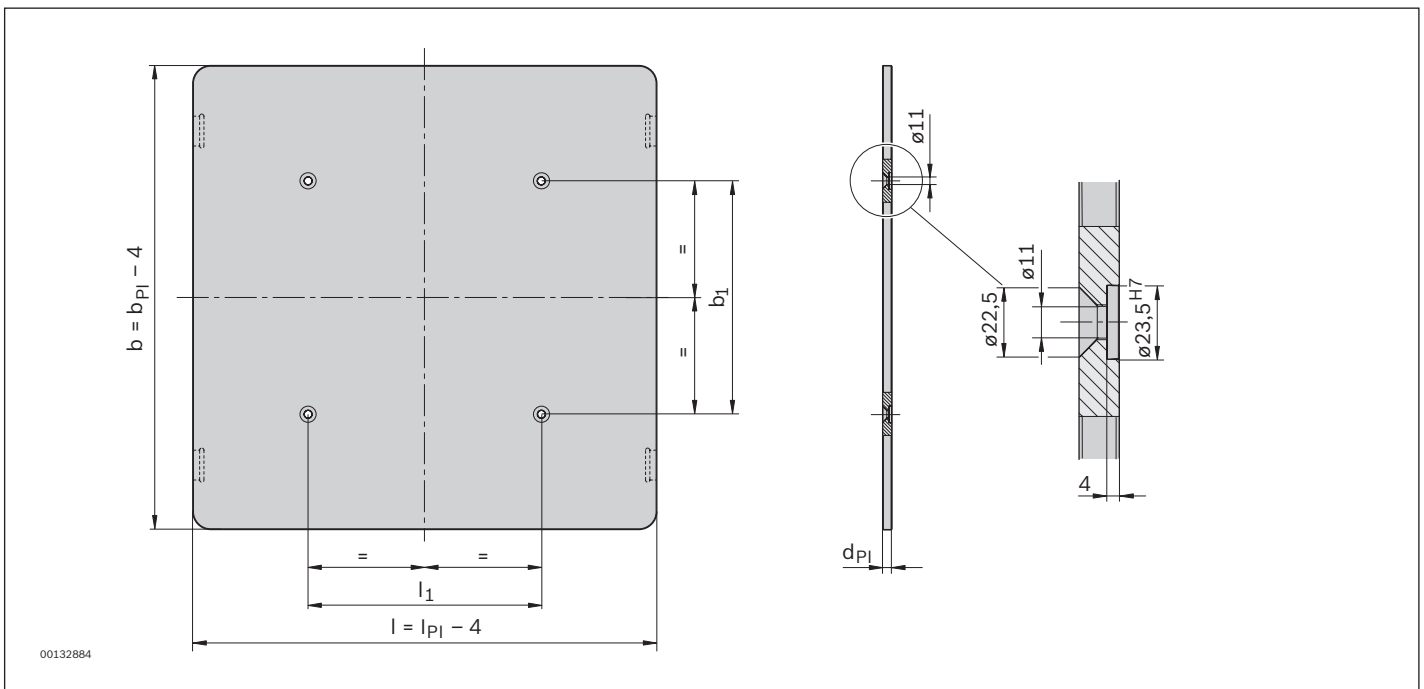

Carrying plates, variable dimensions



Use

- ▶ For combination with a base body to form a workpiece pallet WT 5
- ▶ For finishing fixtures by the user

Version

- ▶ Variable sizes in 2 thicknesses
- ▶ Carrying plate, ready to assemble with mounting holes

Material

- ▶ Aluminum

Notice: The carrying plate may extend beyond all sides of the base body. Exception: The HQ 5 cannot be passed through if the carrying plate protrudes on the sides. The user must install dampers in the direction of transport. To assemble the carrying plate on the base body: Positioning bushing set 3 842 545 264, see page 2-6.

Ordering information

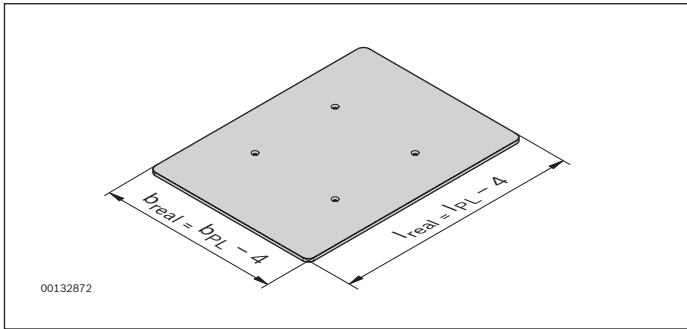

l_{PL} = Ordered length of the carrying plate
 b_{PL} = Ordered width of the carrying plate

Carrying plates in various dimensions, adapted to the base bodys $b_{WT} \times l_{WT}$

$b_{WT} \times l_{WT}$ (mm)	b_{PL} (mm)	l_{PL} (mm)	d_{PL} (mm)	□* (mm)	b_1 (mm)	l_1 (mm)	Material number
455 x 455	$455 \leq b_{PL} \leq 650$	$455 \leq l_{PL} \leq 650$	12.7	0.6	195	195	3 842 998 562
455 x 650	$455 \leq b_{PL} \leq 650$	$650 \leq l_{PL} \leq 845$	12.7	0.8	195	195	3 842 998 564
650 x 650	$650 \leq b_{PL} \leq 845$	$650 \leq l_{PL} \leq 845$	12.7	0.8	195	195	3 842 998 566
650 x 845	$650 \leq b_{PL} \leq 845$	$845 \leq l_{PL} \leq 1040$	12.7	1.0	195	195	3 842 998 568
845 x 845	$845 \leq b_{PL} \leq 1040$	$845 \leq l_{PL} \leq 1040$	12.7	1.0	195	195	3 842 998 570
845 x 1040	$845 \leq b_{PL} \leq 1040$	$1040 \leq l_{PL} \leq 1250$	12.7	1.2	195	195	3 842 998 572
455 x 455	$455 \leq b_{PL} \leq 650$	$455 \leq l_{PL} \leq 650$	19.05	0.6	195	195	3 842 998 563
455 x 650	$455 \leq b_{PL} \leq 650$	$650 \leq l_{PL} \leq 845$	19.05	0.8	195	195	3 842 998 565
650 x 650	$650 \leq b_{PL} \leq 845$	$650 \leq l_{PL} \leq 845$	19.05	0.8	195	195	3 842 998 567
650 x 845	$650 \leq b_{PL} \leq 845$	$845 \leq l_{PL} \leq 1040$	19.05	1.0	195	195	3 842 998 569
845 x 845	$845 \leq b_{PL} \leq 1040$	$845 \leq l_{PL} \leq 1040$	19.05	1.0	195	195	3 842 998 571
845 x 1040	$845 \leq b_{PL} \leq 1040$	$1040 \leq l_{PL} \leq 1250$	19.05	1.2	195	195	3 842 998 573

$b_{WT} \times l_{WT}$ = Base body dimensions
 b_{PL} = Carrying plate width (b_{real}) + 4 mm = Ordered width
 l_{PL} = Carrying plate length (l_{real}) + 4 mm = Ordered length

d_{PL} = Plate thickness
□* = Evenness

Description of further parameters, see page 0-3

Formula for calculating the weight of a carrying plate:

$$m_{PL} \text{ (kg)} = (b_{PL} - 4) \text{ (mm)} \times (l_{PL} - 4) \text{ (mm)} \times d_{PL} \text{ (mm)} \times 0.000027 \text{ (kg/mm}^3\text{)}$$

Order examples:

Standard plate without cut-out for damping element:

- ▶ $b_{PL} = b_{WT} = 455$ mm;
 $l_{PL} = l_{WT} = 455$ mm
Delivery dimensions: 451 mm x 451 mm
- ▶ $b_{PL} = b_{WT} = 650$ mm;
 $l_{PL} = l_{WT} = 650$ mm
Delivery dimensions: 646 mm x 646 mm
- ▶ $b_{PL} = b_{WT} = 845$ mm;
 $l_{PL} = l_{WT} = 845$ mm
Delivery dimensions: 841 mm x 841 mm

Dimensions

WT 5: Carrying plate, variable dimensions

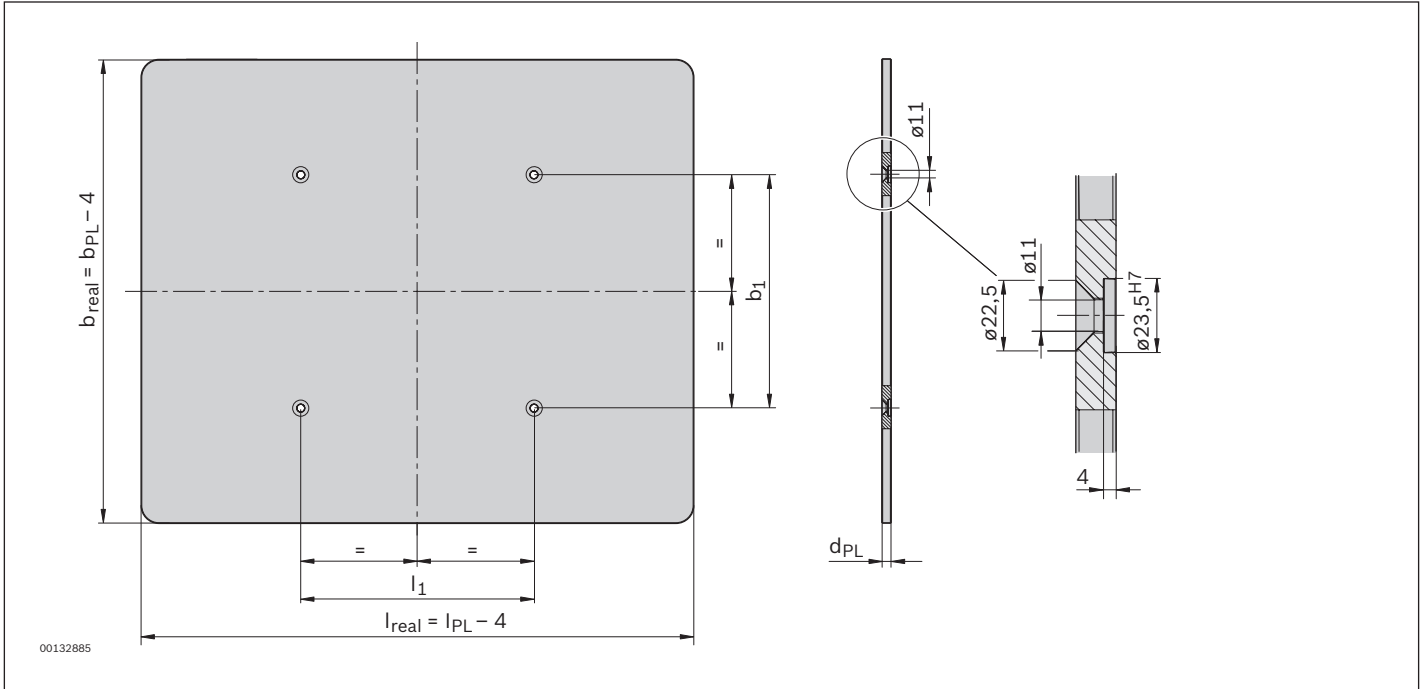

Formula for calculating the weight of a carrying plate:

$$m_{PL} \text{ (kg)} = (b_{PL} - 4) \text{ (mm)} \times (l_{PL} - 4) \text{ (mm)} \times d_{PL} \text{ (mm)} \times 0.0000027 \text{ (kg/mm}^3\text{)}$$

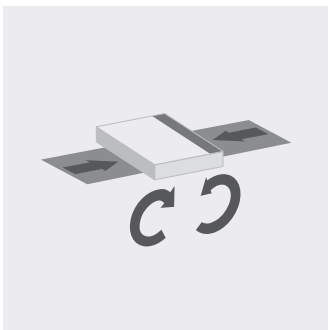

Drive unit

3

Design	3-2
Drive layout	3-3
Drive units AS 5/XH, AS 5/H (with split rollers)	3-4
Drive units AS 5/XH-FR, AS 5/H-FR (with full rollers)	3-9
Drive units AS 5/OC (Open Center)	3-14
Drive options for an Open Center section	3-19
Selection of gear motor GM on AS 5	3-20
Drive kit AB 5	3-21
End plates for AB 5 with ST 5/XH, ST 5/H, ST 5/XH-FR, ST 5/H-FR	3-24
End plates for AB 5 with ST 5/OC	3-26
Connection kit AB 5 on CU 5	3-28
Selection of gear motor GM on AB 5	3-30
Frequency converter (FU)	3-31
Frequency converter (FU) accessories	

Design

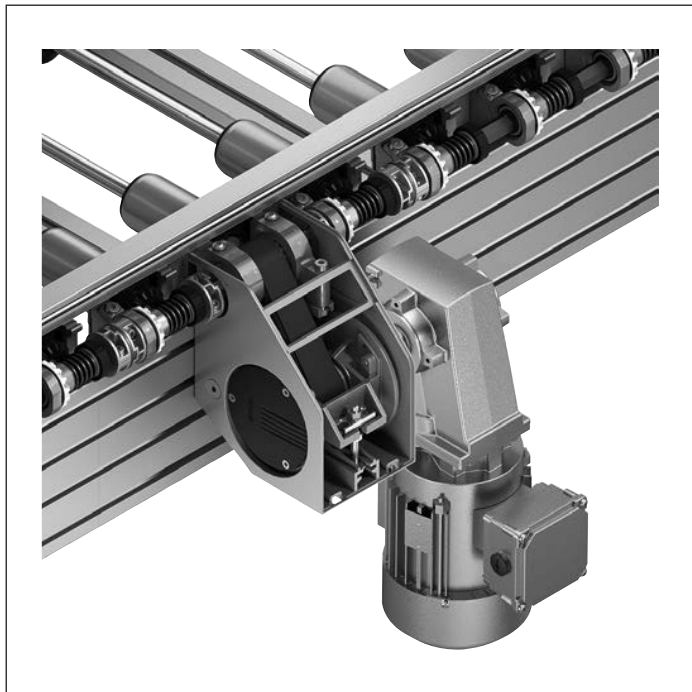

Drive units

Ready-for-operation module to drive conveyor units, curves, diverters, and junctions in 4 system widths and 2 load classes. Versions available with split rollers, full roller or Open Center.

The rollers in the conveyor section are driven by a king shaft in the drive unit.

The king shaft is located behind a protective cover below the transport level; the workpiece pallet can pass over the king shaft.

The length of the driven conveyor section depends on the roller spacing. A drive torque of up to 45 Nm (in reversible operation: 20 Nm) is enough to drive a section of up to 10 m with 2 curves/diverters, or a straight section of up to 21 m, with roller spacing of 195 mm and 80% of the section in accumulation operation. The torque in reversible operation is only reduced if the conveying direction changes during ongoing operation.

Attachment options for the gear motor

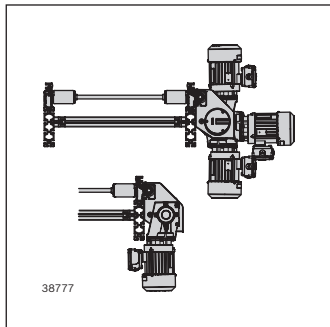

Standard

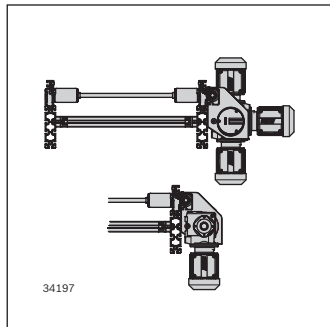

Customer-specific motor

Required accessories

- ▶ Leg sets SZ 5/..., see page 7-1
- ▶ Connection kit, see page 4-25

Notice: The roller which is located directly on the transmission drive is not driven at a roller spacing of 130 mm. Do not install a stop gate on this roller.

Note:

The drive kit AB 5 (see page 3-21) is available for implementing a face-side drive.

Drive layout

When laying out the system, make sure that there is enough drive power for the entire conveyor section.

The rollers are driven by the drive unit or by the drive kit via a king shaft. A friction clutch on each roller prevents blocking of the drive.

The maximum transferable total torque results from the torque present briefly before an individual coupling slides, multiplied by the total number of rollers in the section.

Example layout:

Drive torque 45 Nm, each roller loads the drive with 0.5 Nm (with a sliding coupling). Each curve, diverter, or junction loads the drive with 12 Nm per direction of transport. Due to the keyway connection, 20 Nm must be assumed when changing the conveying direction during operation.

Notice: Install the motor as close as possible to the center of the section.

The driven rollers of the drive module itself are included in the calculation (if $p = 130$ one drive module roller is not being driven).

The cables between the frequency converter and the motor must not be longer than 10 m.

Example A:

Section, $b = 650$ mm, with roller division $p = 130$ mm and a curve; 100% of the section in accumulation operation

Question: If one drive unit is used, how long may the straight section be?

Calculation:

$45 \text{ Nm} - 12 \text{ Nm (for curve)} = 33 \text{ Nm}$ remaining for the straight section
 $33 \text{ Nm} \div 0.5 \text{ Nm} = 66$ (driven rollers)

$66 \times 130 \text{ mm} = 8580 \text{ mm}$ straight section.

Note:

If a section is not operated completely in accumulation operation, the section length can be multiplied by a corresponding factor. For example, with 50% accumulation operation in the case of example A the section length is doubled to 17160 mm ($2 \times 66 \times 130 \text{ mm}$).

Example B:

Section, $b = 650$ mm, length 20 m, $p = 130$, includes 1 diverter and 1 curve; 100% of the section in accumulation operation

Question: Will one drive unit be sufficient?

Calculation:

$45 \text{ Nm} - 12 \text{ Nm (diverter)} - 12 \text{ Nm (curve)} = 21 \text{ Nm}$ remaining for the straight section

$20000 \text{ mm} - 1560 \text{ mm (diverter)} - 1149 \text{ mm (curve)}$
 $= 17291 \text{ mm}$ straight section

Values taken from the following tables:

Diverter, page 5-8 and curve, page 5-4

$17291 \text{ mm} \div 130 \text{ mm} = 133$ rollers

$133 \times 0.5 \text{ Nm} = 66.5 \text{ Nm}$

$66.5 \text{ Nm} > 21 \text{ Nm}$, 2 drives are therefore needed in order to attain the torque to be transferred.

Note:

If a section is not operated completely in accumulation operation, the section length can be multiplied by a corresponding factor. For example, with 30% accumulation operation in the case of example B the required torque is reduced to: $66.5 \text{ Nm} \times 30\% = 19.95 \text{ Nm} < 21 \text{ Nm}$.

In this case, only one drive would be needed.

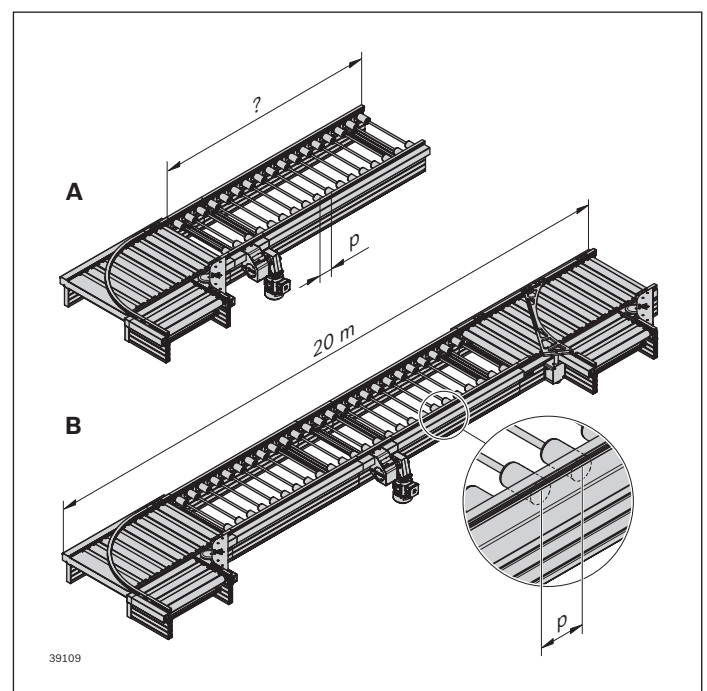

Drive units AS 5/XH, AS 5/H (with split rollers)

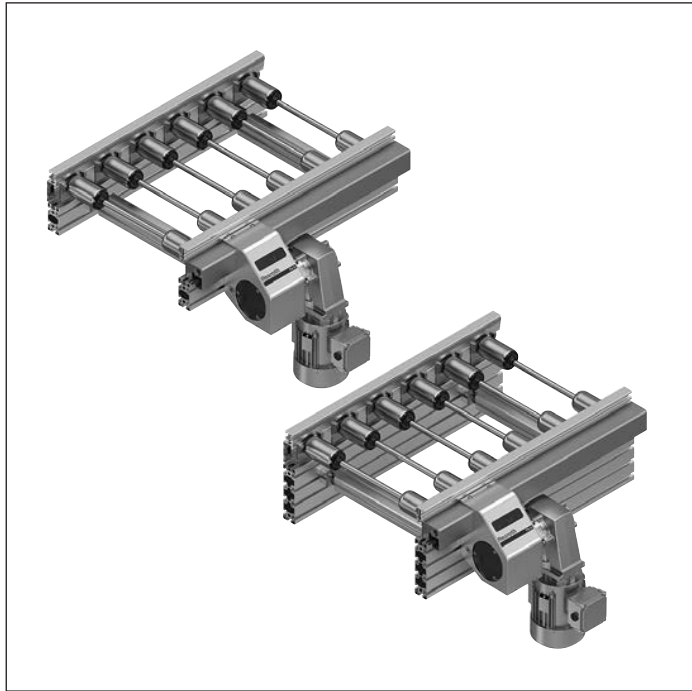

Condition on delivery

- ▶ Ready-to-install, gear motor enclosed separately
- ▶ Mounting option for the gear motor on the right/left possible, see page 3-2

Material

- ▶ Shaft: Brass

Use

To drive

- ▶ Conveyor units ST 5/...
- ▶ Curves CU 5/...
- ▶ Diverters DI 5/...
- ▶ Junctions JU 5/...
- ▶ Lift transverse unit HQ 5/...

Version

- ▶ Reversible operation possible
- ▶ Accumulation operation possible
- ▶ Motor connection with plug (AT = S) or terminal box (AT = K)
- ▶ Freely selectable motor position and length
- ▶ Gear motor can be mounted on both sides on the transmission drive (MA = R and MA = L)
- ▶ Viewing window for checking the toothed belt
- ▶ Due to the simple and space-saving disassembly of the cover, adjacent components/machines can be positioned at a distance of 20 mm from the AS 5
- ▶ Frequency converter, optional, see page 3-31
- ▶ Suitable for cleanroom of ISO class 7
- ▶ Suitable for dry room <1% RH

Ordering information

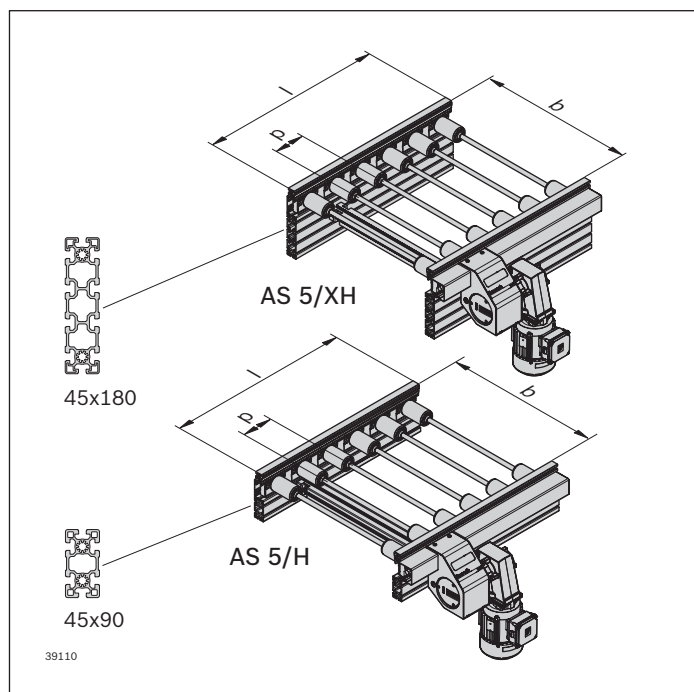

Drive units AS 5/XH, AS 5/H

Product description	Material number
AS 5/XH	3 842 998 837
AS 5/H	3 842 998 838
	b = ... mm
	l_{WT} = ... mm
	p = ... mm, see page 3-8
	l = ... mm
	LG = ...
	BG = ...
	TR = ...
	GM = ...
	v_N = ... m/min, see page 13-9
	U = ... V, see page 13-8
	f = ... Hz, see page 13-8
	AT = ...
	MA = ...
	DP = ..., see page 3-8

3

Drive units AS 5/XH, AS 5/H

b (mm)	l_{WT} (mm)	p (mm)	l (mm)	N	LG	BG	TR	GM	AT	MA	DP
455	455; 650	130	390 ... 4160	3; 4 ... 32	1; 2; 3	1; 2	1; 2	0; 1; 2	K; S	R; L	1; 2 ... n
455	650	195	585 ... 4095	3; 4 ... 21	1; 2; 3	1; 2	1; 2	0; 1; 2	K; S	R; L	1; 2 ... 20
650	650; 845	130	390 ... 4160	3; 4 ... 32	1; 2; 3	1; 2	1; 2	0; 1; 2	K; S	R; L	1; 2 ... n
650	650; 845	195	585 ... 4095	3; 4 ... 21	1; 2; 3	1; 2	1; 2	0; 1; 2	K; S	R; L	1; 2 ... 20
650	845	260	780 ... 4160	3; 4 ... 16	1; 2; 3	1; 2	1; 2	0; 1; 2	K; S	R; L	1; 2 ... 15
845	845; 1040	130	390 ... 4160	3; 4 ... 32	1; 2; 3	1; 2	1; 2	0; 1; 2	K; S	R; L	1; 2 ... n
845	845; 1040	195	585 ... 4095	3; 4 ... 21	1; 2; 3	1; 2	1; 2	0; 1; 2	K; S	R; L	1; 2 ... 20
845	845; 1040	260	780 ... 4160	3; 4 ... 16	1; 2; 3	1; 2	1; 2	0; 1; 2	K; S	R; L	1; 2 ... 15
845	1040	325	975 ... 3900	3; 4 ... 12	1; 2; 3	1; 2	1; 2	0; 1; 2	K; S	R; L	1; 2 ... 11
1040	845	130	390 ... 4160	3; 4 ... 32	1; 2; 3	1; 2	1; 2	0; 1; 2	K; S	R; L	1; 2 ... n
1040	845	195	585 ... 4095	3; 4 ... 21	1; 2; 3	1; 2	1; 2	0; 1; 2	K; S	R; L	1; 2 ... 20
1040	845	260	780 ... 4160	3; 4 ... 16	1; 2; 3	1; 2	1; 2	0; 1; 2	K; S	R; L	1; 2 ... 15

- b = Track width
- l_{WT} = Length of workpiece pallet
- p = Roller spacing (pitch)
- l = Length graduated according to the roller dimensions ($l = p \times N$)
- N = Number of rollers, multiplier for length ($l = p \times N$), pricing factor in the price list
- LG = Lateral guide material
 - 1: Steel
 - 2: Plastic
 - 3: Aluminum
- BG = Bevel wheel material
 - 1: Plastic
 - 2: Sintered metal
- TR = Roller material
 - 1: Steel, galvanized
 - 2: Steel, nitrocarburized
- GM = Gear motor
 - 0: without (interface SW27)
 - 1: with gear motor SW27
 - 2: without (interface to connection SEW, round shaft $\varnothing 20$)
- v_N = Nominal speed (m/min);
 - 2*; 4*; 6; 9; 12; 15; 18
 - = 0 (without gear motor)
- AT = Motor connection
 - K: with terminal box
 - S: with plug
- MA = Motor mounting
 - R: Right
 - L: Left
- DP = Drive position

* Additional measures may be necessary

Dimensions

Drive module AS 5/XH, AS 5/H, pitch $p = 130$ mm

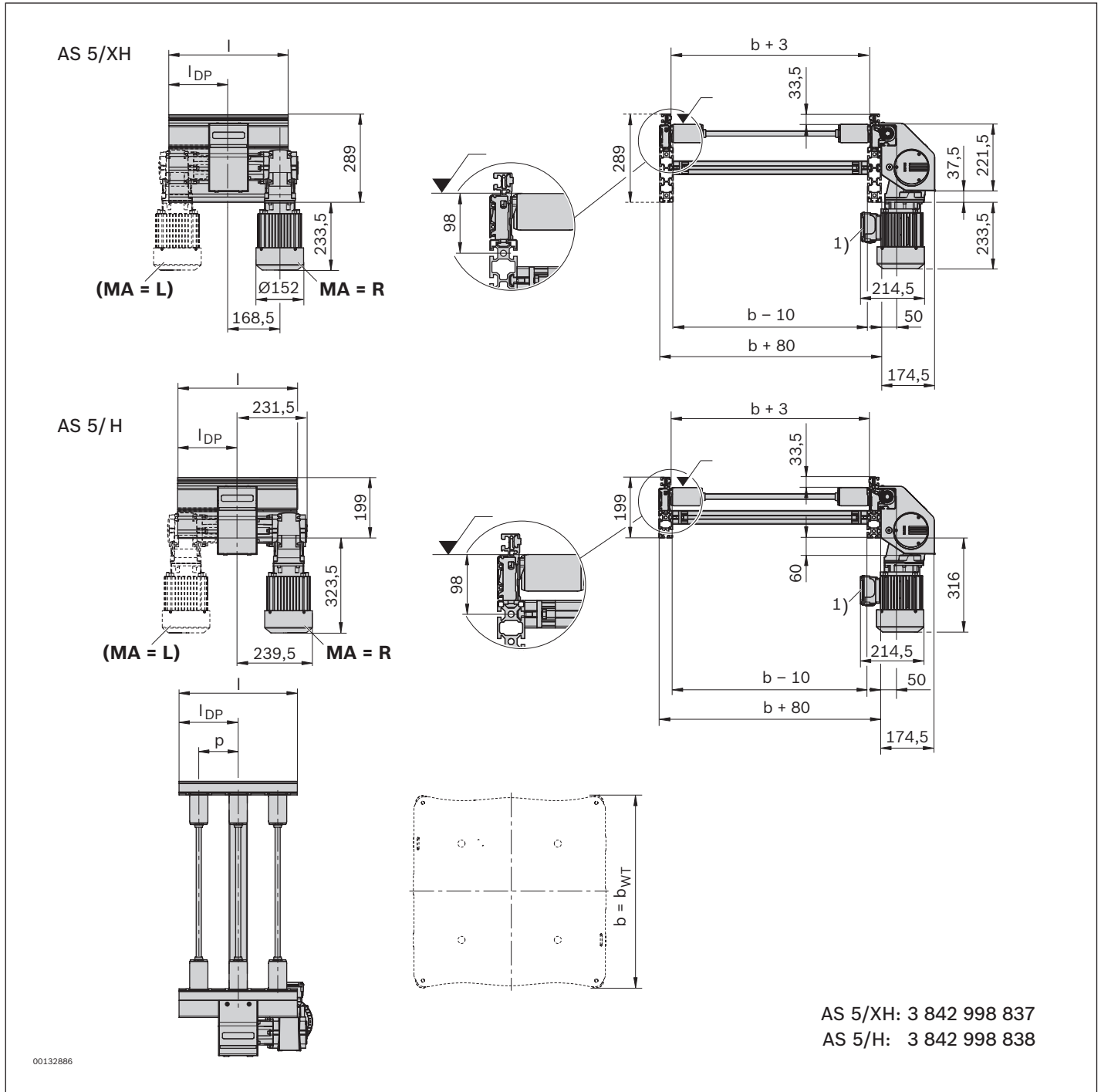

¹⁾ **Notice:** In this depiction, the terminal box can collide with the leg sets. It protrudes into the section.

I = $p \times N$

I_{DP} = $DP \times p - p/2$

p = Roller spacing (pitch)

N = Number of rollers

DP = Drive position

Description of parameters, see page 3-5

Dimensions

Drive module AS 5/XH, AS 5/H, pitch $p = 195 \text{ mm}$; $p = 260 \text{ mm}$; $p = 325 \text{ mm}$

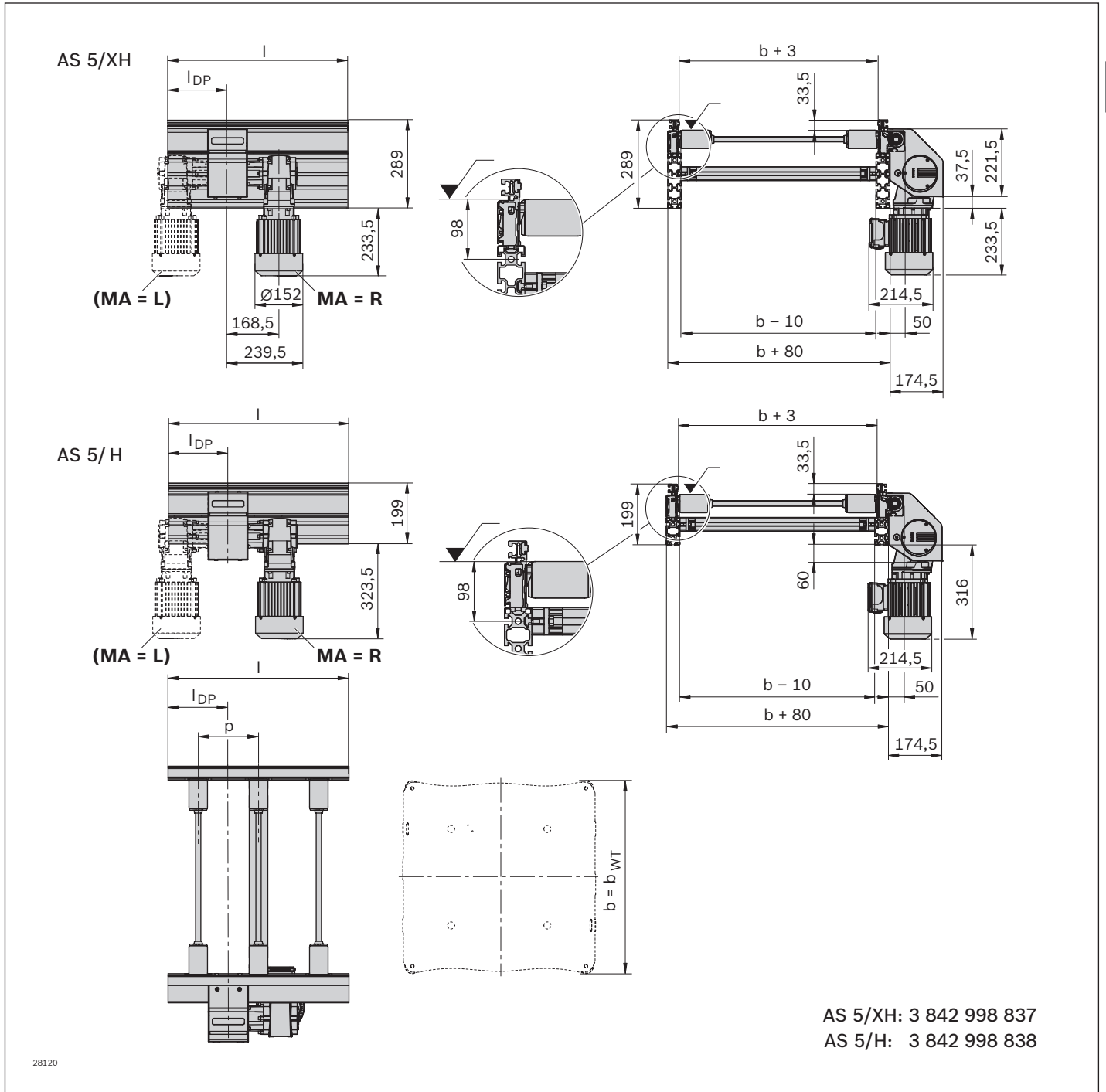

l = $p \times N$
 l_{DP} = $DP \times p$

p = Roller spacing (pitch)
 N = Number of rollers
 DP = Drive position

Description of parameters, see page 3-5

Pitch p and drive position DP

$p = 130 \text{ mm}$

DP is the roller to which the transmission drive is fitted.
 This roller is not driven.

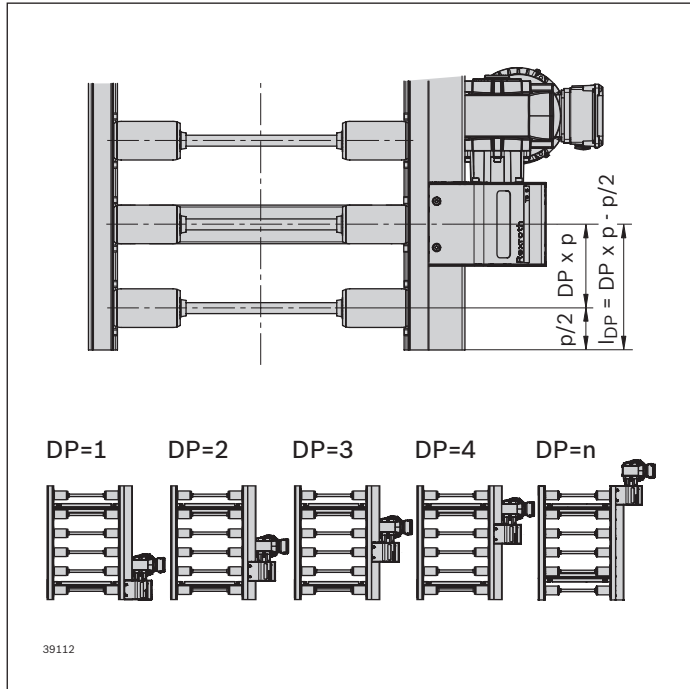

Example: DP = 2

Possible drive positions DP with pitch p

p (mm)	MA	DP
130	R; L	1 ... 31

Notice: Only if $p = 130 \text{ mm}$:

Roller corresponding to DP is not driven.
 Gear motor can be mounted on both sides.

Permissible position l_{DP} (mm) after start of section:

$$l_{DP} = DP \times p - p/2$$

Example for $p = 130 \text{ mm}$ and $DP = 10$:

$$l_{DP} = 10 \times 130 \text{ mm} - 65 \text{ mm} = 1235 \text{ mm}$$

Description of further parameters, see page 3-5

$p = 195 \text{ mm}; p = 260 \text{ mm}; p = 325 \text{ mm}$

DP is the space between two rollers in which the transmission drive is fitted.

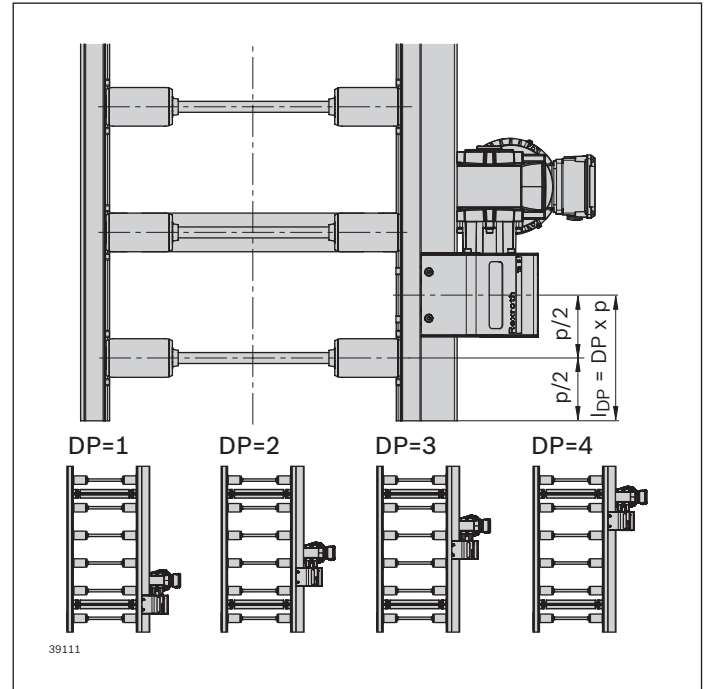

Example: DP = 1

Possible drive positions DP with pitch p

p (mm)	MA	DP
195	R; L	1 ... 20
260	R; L	1 ... 15
325	R; L	1 ... 11

Permissible position l_{DP} (mm) after start of section:

$$l_{DP} = DP \times p$$

Example for $p = 260 \text{ mm}$ and $DP = 5$:

$$l_{DP} = 5 \times 260 \text{ mm} = 1300 \text{ mm}$$

Drive units AS 5/XH-FR, AS 5/H-FR (with full rollers)



Condition on delivery

- ▶ Ready-to-install, gear motor enclosed separately
- ▶ Mounting option for the gear motor on the right/left possible, see page 3-2

Material

- ▶ Shaft: Brass

Use

To drive

- ▶ Conveyor units ST 5/...-FR
- ▶ Curves CU 5/...-FR
- ▶ Diverters DI 5/...-FR
- ▶ Junctions JU 5/...-FR
- ▶ Lift transverse unit HQ 5/...

Version

- ▶ Reversible operation possible
- ▶ Accumulation operation possible
- ▶ Motor connection with plug (AT = S) or terminal box (AT = K)
- ▶ Freely selectable motor position and length
- ▶ Gear motor can be mounted on both sides on the transmission drive (MA = R and MA = L)
- ▶ Viewing window for checking the toothed belt
- ▶ Due to the simple and space-saving disassembly of the cover, adjacent components/machines can be positioned at a distance of 20 mm from the AS 5
- ▶ Frequency converter, optional, see page 3-31
- ▶ Suitable for cleanroom of ISO class 7
- ▶ Suitable for dry room <1% RH

Notice: To transport workpieces without workpiece pallets. Use plastic lateral guides to ensure the workpiece is not damaged!

Ordering information

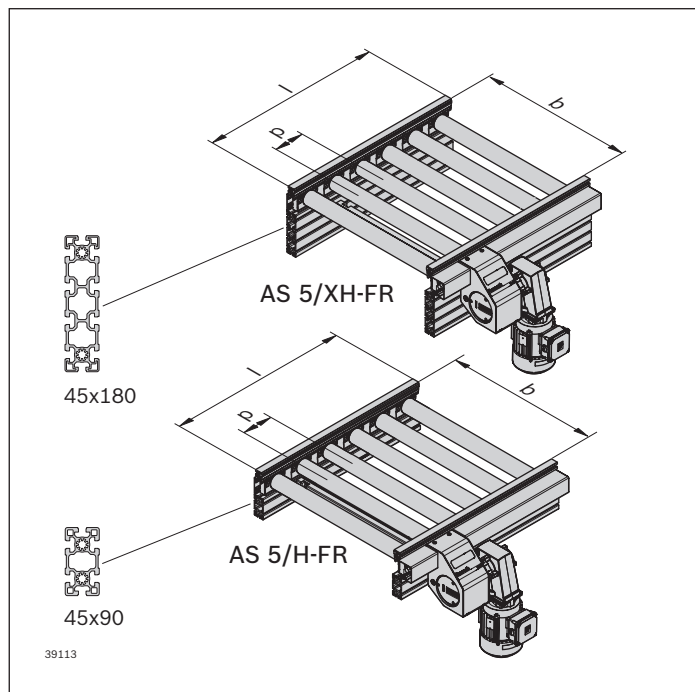

Drive units AS 5/XH-FR, AS 5/H-FR

Product description	Material number
AS 5/XH-FR	3 842 998 839
AS 5/H-FR	3 842 998 840
	b = ... mm
	l_{WT} = ... mm
	p = ... mm, see page 3-13
	l = ... mm
	LG = ...
	BG = ...
	TR = ...
	GM = ...
	v_N = ... m/min, see page 13-9
	U = ... V, see page 13-8
	f = ... Hz, see page 13-8
	AT = ...
	MA = ...
	DP = ..., see page 3-13

Drive units AS 5/XH-FR, AS 5/H-FR

b (mm)	l_{WT} (mm)	p (mm)	l (mm)	N	LG	BG	TR	GM	AT	MA	DP
455	455; 650	130	390 ... 4160	3; 4 ... 32	1; 2; 3	1; 2	1; 2	0; 1; 2	K; S	R; L	1; 2 ... n
455	650	195	585 ... 4095	3; 4 ... 21	1; 2; 3	1; 2	1; 2	0; 1; 2	K; S	R; L	1; 2 ... 20
650	650; 845	130	390 ... 4160	3; 4 ... 32	1; 2; 3	1; 2	1; 2	0; 1; 2	K; S	R; L	1; 2 ... n
650	650; 845	195	585 ... 4095	3; 4 ... 21	1; 2; 3	1; 2	1; 2	0; 1; 2	K; S	R; L	1; 2 ... 20
650	845	260	780 ... 4160	3; 4 ... 16	1; 2; 3	1; 2	1; 2	0; 1; 2	K; S	R; L	1; 2 ... 15
845	845; 1040	130	390 ... 4160	3; 4 ... 32	1; 2; 3	1; 2	1; 2	0; 1; 2	K; S	R; L	1; 2 ... n
845	845; 1040	195	585 ... 4095	3; 4 ... 21	1; 2; 3	1; 2	1; 2	0; 1; 2	K; S	R; L	1; 2 ... 20
845	845; 1040	260	780 ... 4160	3; 4 ... 16	1; 2; 3	1; 2	1; 2	0; 1; 2	K; S	R; L	1; 2 ... 15
845	1040	325	975 ... 3900	3; 4 ... 12	1; 2; 3	1; 2	1; 2	0; 1; 2	K; S	R; L	1; 2 ... 11
1040	845	130	390 ... 4160	3; 4 ... 32	1; 2; 3	1; 2	1; 2	0; 1; 2	K; S	R; L	1; 2 ... n
1040	845	195	585 ... 4095	3; 4 ... 21	1; 2; 3	1; 2	1; 2	0; 1; 2	K; S	R; L	1; 2 ... 20
1040	845	260	780 ... 4160	3; 4 ... 16	1; 2; 3	1; 2	1; 2	0; 1; 2	K; S	R; L	1; 2 ... 15

b = Track width	BG = Bevel wheel material	v_N = Nominal speed (m/min);
l_{WT} = Length of workpiece pallet	1: Plastic	2*; 4*; 6; 9; 12; 15; 18
p = Roller spacing (pitch)	2: Sintered metal	= 0 (without gear motor)
l = Length graduated according to the roller dimensions ($l = p \times N$)	TR = Roller material	AT = Motor connection
N = Number of rollers, multiplier for length ($l = p \times N$), pricing factor in the price list	1: Steel, galvanized	K: with terminal box
LG = Lateral guide material	2: Steel, nitrocarburized	S: with plug
1: Steel	GM = Gear motor	MA = Motor mounting
2: Plastic	0: without (interface SW27)	R: Right
3: Aluminum	1: with gear motor SW27	L: Left
	2: without (interface to connection SEW, round shaft $\varnothing 20$)	DP = Drive position
		* Additional measures may be necessary

Dimensions

Drive module AS 5/XH-FR, AS 5/H-FR, pitch $p = 130$ mm

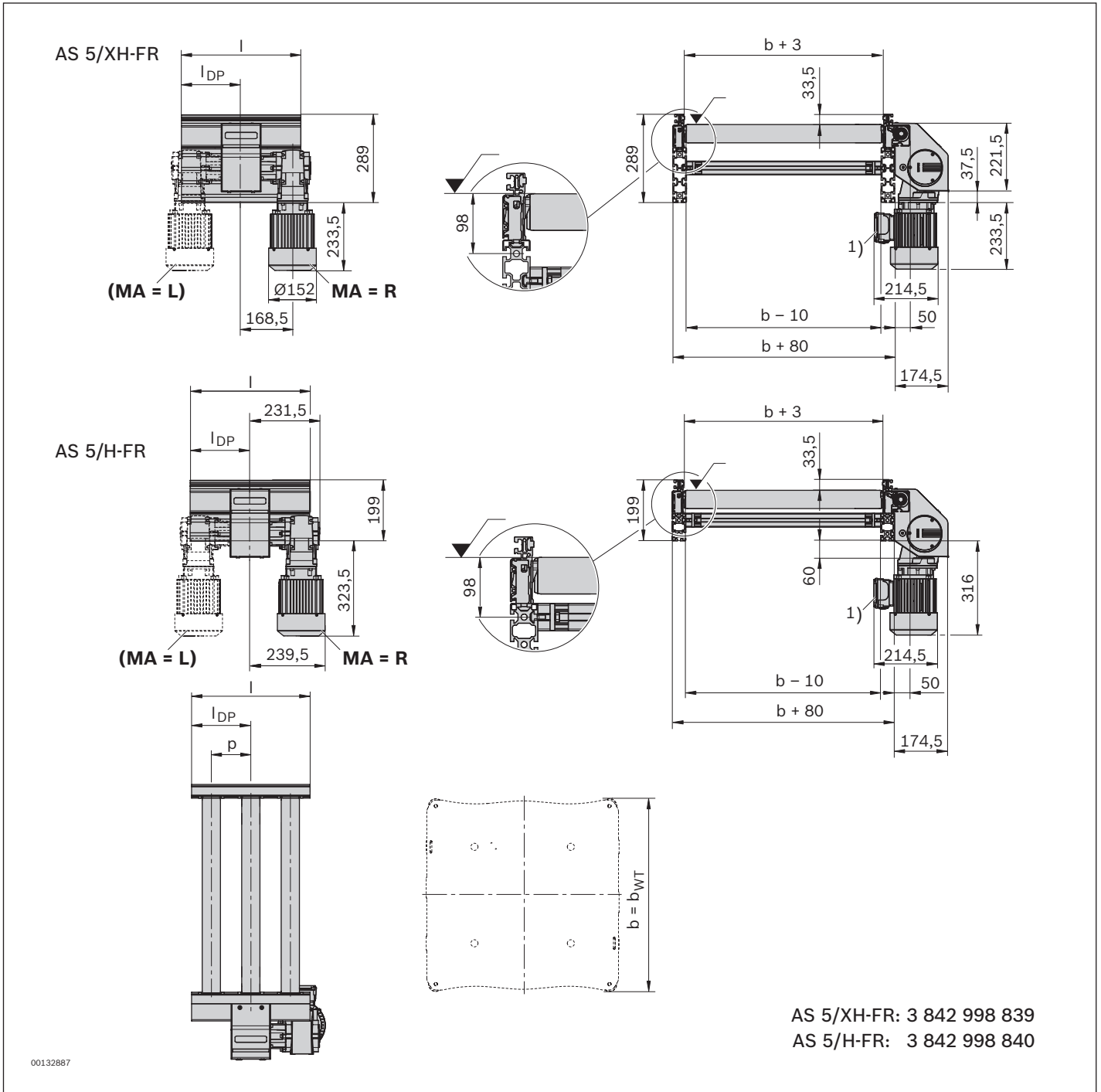

¹⁾ **Notice:** In this depiction, the terminal box can collide with the leg sets. It protrudes into the section.

l = $p \times N$
 l_{DP} = $DP \times p - p/2$

p = Roller spacing (pitch)
 N = Number of rollers
 DP = Drive position

Description of parameters, see page 3-10

Dimensions

Drive module AS 5/XH-FR, AS 5/H-FR, pitch $p = 195$ mm; $p = 260$ mm; $p = 325$ mm

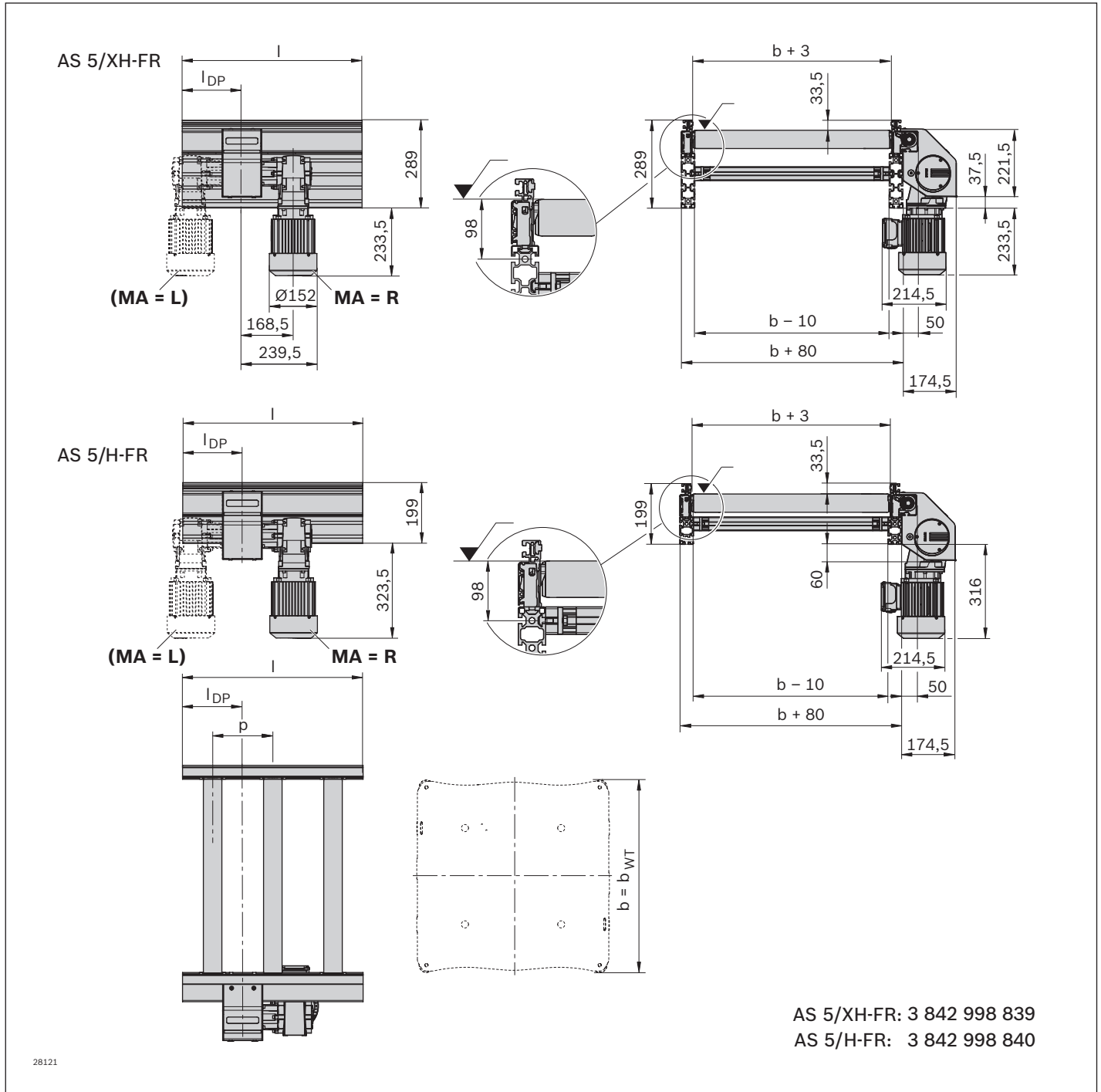

l = $p \times N$
 l_{DP} = $DP \times p$

p = Roller spacing (pitch)
 N = Number of rollers
 DP = Drive position

Description of parameters, see page 3-10

Pitch p and drive position DP

p = 130 mm

DP is the roller to which the transmission drive is fitted.
 This roller is not driven.

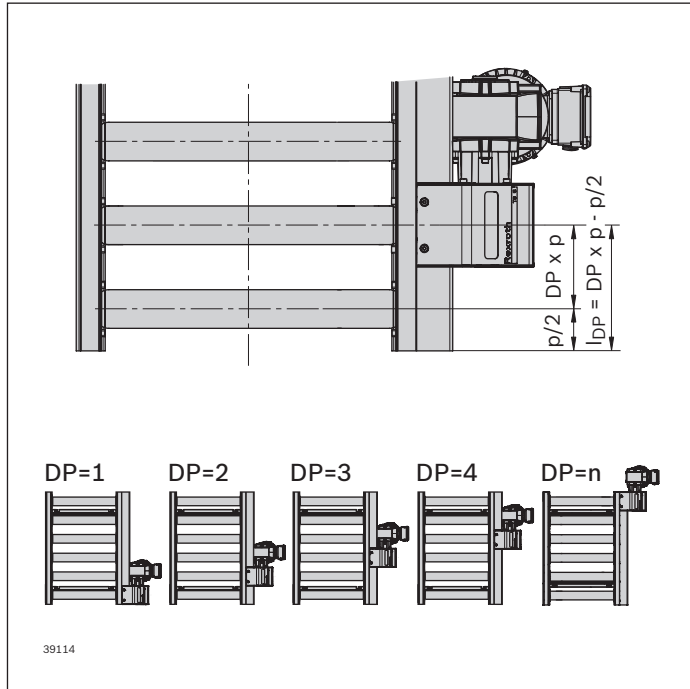

Example: DP = 2

Possible drive positions DP with pitch p

p (mm)	MA	DP
130	R; L	1 ... 31

Notice: Only if p = 130 mm:

Roller corresponding to DP is not driven.

Gear motor can be mounted on both sides.

Permissible position l_{DP} (mm) after start of section:

$$l_{DP} = DP \times p - p/2$$

Example for p = 130 mm and DP = 10:

$$l_{DP} = 10 \times 130 \text{ mm} - 65 \text{ mm} = 1235 \text{ mm}$$

Description of further parameters, see page 3-10

p = 195 mm; p = 260 mm; p = 325 mm

DP is the space between two rollers in which the transmission drive is fitted.

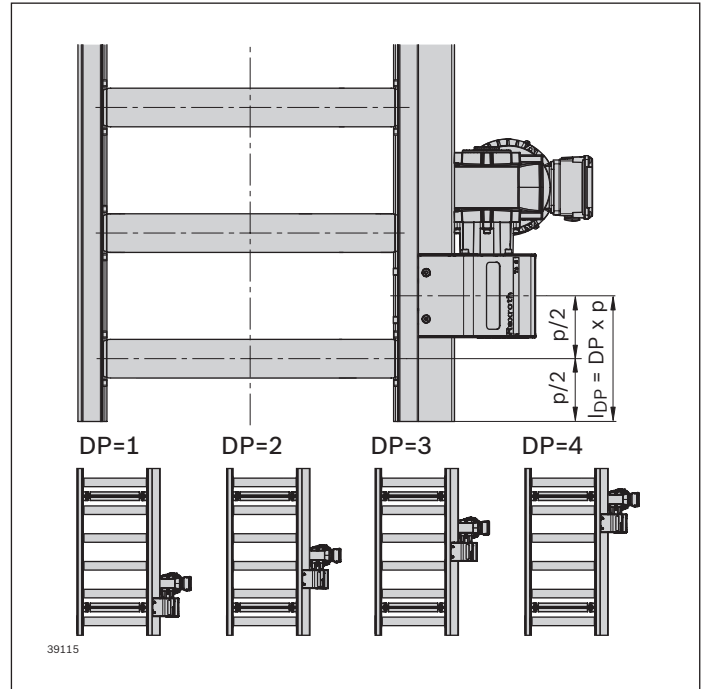

Example: DP = 1

Possible drive positions DP with pitch p

p (mm)	MA	DP
195	R; L	1 ... 20
260	R; L	1 ... 15
325	R; L	1 ... 11

Permissible position l_{DP} (mm) after start of section:

$$l_{DP} = DP \times p$$

Example for p = 260 mm and DP = 5:

$$l_{DP} = 5 \times 260 \text{ mm} = 1300 \text{ mm}$$

Drive units AS 5/OC (Open Center)

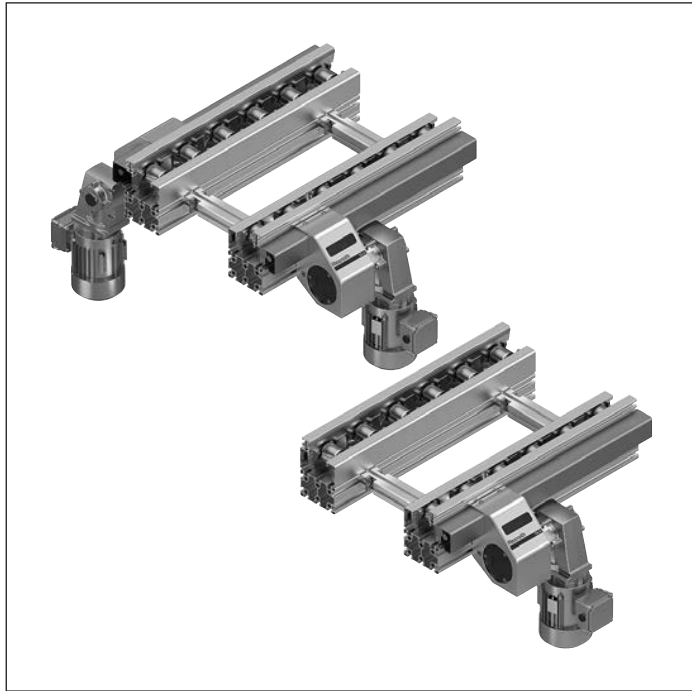

Condition on delivery

- ▶ Ready-to-install, gear motor enclosed separately
- ▶ Mounting option for the gear motor on the right/left possible, see page 3-2

Material

- ▶ Shaft: Brass

Use

To drive

- ▶ Conveyor units ST 5/OC...

Version

- ▶ Reversible operation possible
- ▶ Accumulation operation possible
- ▶ Motor connection with plug (AT = S) or terminal box (AT = K)
- ▶ Freely selectable motor position and length
- ▶ Gear motor can be mounted on both sides on the transmission drive (MA = R and MA = L)
- ▶ Viewing window for checking the toothed belt
- ▶ Due to the simple and space-saving disassembly of the cover, adjacent components/machines can be positioned at a distance of 20 mm from the AS 5
- ▶ Frequency converter, optional, see page 3-31
- ▶ Suitable for cleanroom of ISO class 7
- ▶ Suitable for dry room <1% RH

Notice: Please take account of the load center of gravity when selecting the drive, see page 3-19

Ordering information

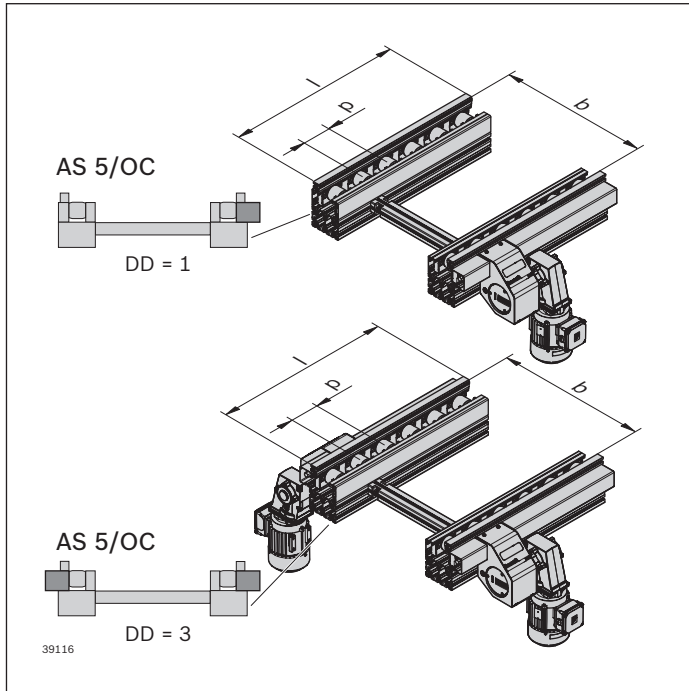

Drive units AS 5/OC

Product description	Material number
AS 5/OC	3 842 998 841
	b = ... mm
	l_{WT} = ... mm
	p = ... mm, see page 3-18
	l = ... mm
	LG = ...
	BG = ...
	TR = ...
	GM = ...
	DD = ...
	v_N = ... m/min, see page 13-9
	U = ... V, see page 13-8
	f = ... Hz, see page 13-8
	AT = ...
	MA = ...
	DP_r/DP_l = ..., see page 3-18

Drive units AS 5/OC

b (mm)	l_{WT} (mm)	p (mm)	l (mm)	N	LG	BG	TR	GM	DD	AT	MA	DP_r/DP_l
455	455; 650	130	390 ... 4160	3; 4 ... 32	1; 2; 3	1; 2	1; 2	0; 1; 2	1; 2; 3	K; S	R; L	1; 2 ... n
455	650	195	585 ... 4095	3; 4 ... 21	1; 2; 3	1; 2	1; 2	0; 1; 2	1; 2; 3	K; S	R; L	1; 2 ... 20
650	650; 845	130	390 ... 4160	3; 4 ... 32	1; 2; 3	1; 2	1; 2	0; 1; 2	1; 2; 3	K; S	R; L	1; 2 ... n
650	650; 845	195	585 ... 4095	3; 4 ... 21	1; 2; 3	1; 2	1; 2	0; 1; 2	1; 2; 3	K; S	R; L	1; 2 ... 20
650	845	260	780 ... 4160	3; 4 ... 16	1; 2; 3	1; 2	1; 2	0; 1; 2	1; 2; 3	K; S	R; L	1; 2 ... 15
845	845; 1040	130	390 ... 4160	3; 4 ... 32	1; 2; 3	1; 2	1; 2	0; 1; 2	1; 2; 3	K; S	R; L	1; 2 ... n
845	845; 1040	195	585 ... 4095	3; 4 ... 21	1; 2; 3	1; 2	1; 2	0; 1; 2	1; 2; 3	K; S	R; L	1; 2 ... 20
845	845; 1040	260	780 ... 4160	3; 4 ... 16	1; 2; 3	1; 2	1; 2	0; 1; 2	1; 2; 3	K; S	R; L	1; 2 ... 15
845	1040	325	975 ... 3900	3; 4 ... 12	1; 2; 3	1; 2	1; 2	0; 1; 2	1; 2; 3	K; S	R; L	1; 2 ... 11
1040	845	130	390 ... 4160	3; 4 ... 32	1; 2; 3	1; 2	1; 2	0; 1; 2	1; 2; 3	K; S	R; L	1; 2 ... n
1040	845	195	585 ... 4095	3; 4 ... 21	1; 2; 3	1; 2	1; 2	0; 1; 2	1; 2; 3	K; S	R; L	1; 2 ... 20
1040	845	260	780 ... 4160	3; 4 ... 16	1; 2; 3	1; 2	1; 2	0; 1; 2	1; 2; 3	K; S	R; L	1; 2 ... 15

- b = Track width
 - l_{WT} = Length of workpiece pallet
 - p = Roller spacing (pitch)
 - l = Length graduated according to the roller dimensions ($l = p \times N$)
 - N = Number of rollers, multiplier for length ($l = p \times N$), pricing factor in the price list
 - LG = Lateral guide material
 1: Steel
 2: Plastic
 3: Aluminum
 - BG = Bevel wheel material
 1: Plastic
 2: Sintered metal
 - TR = Roller material
 1: Steel, galvanized
 2: Steel, nitrocarburized
 - GM = Gear motor
 0: without (interface SW27)
 1: with gear motor SW27
 2: without (interface to connection SEW, round shaft $\varnothing 20$)
 - DD = Drive
 1: on one side with 1 gear motor
 2: on two sides with 1 gear motor
 3: on two sides with 2 gear motors
 - v_N = Nominal speed (m/min);
 2*; 4*; 6; 9; 12; 15; 18
 = 0 (without gear motor)
 - AT = Motor connection
 K: with terminal box
 S: with plug
 - MA = Motor mounting
 R: Right
 L: Left
 - DP_r = Drive position
 DP_l
- * Additional measures may be necessary

Dimensions

Drive module AS 5/OC (Open Center), pitch $p = 130$ mm

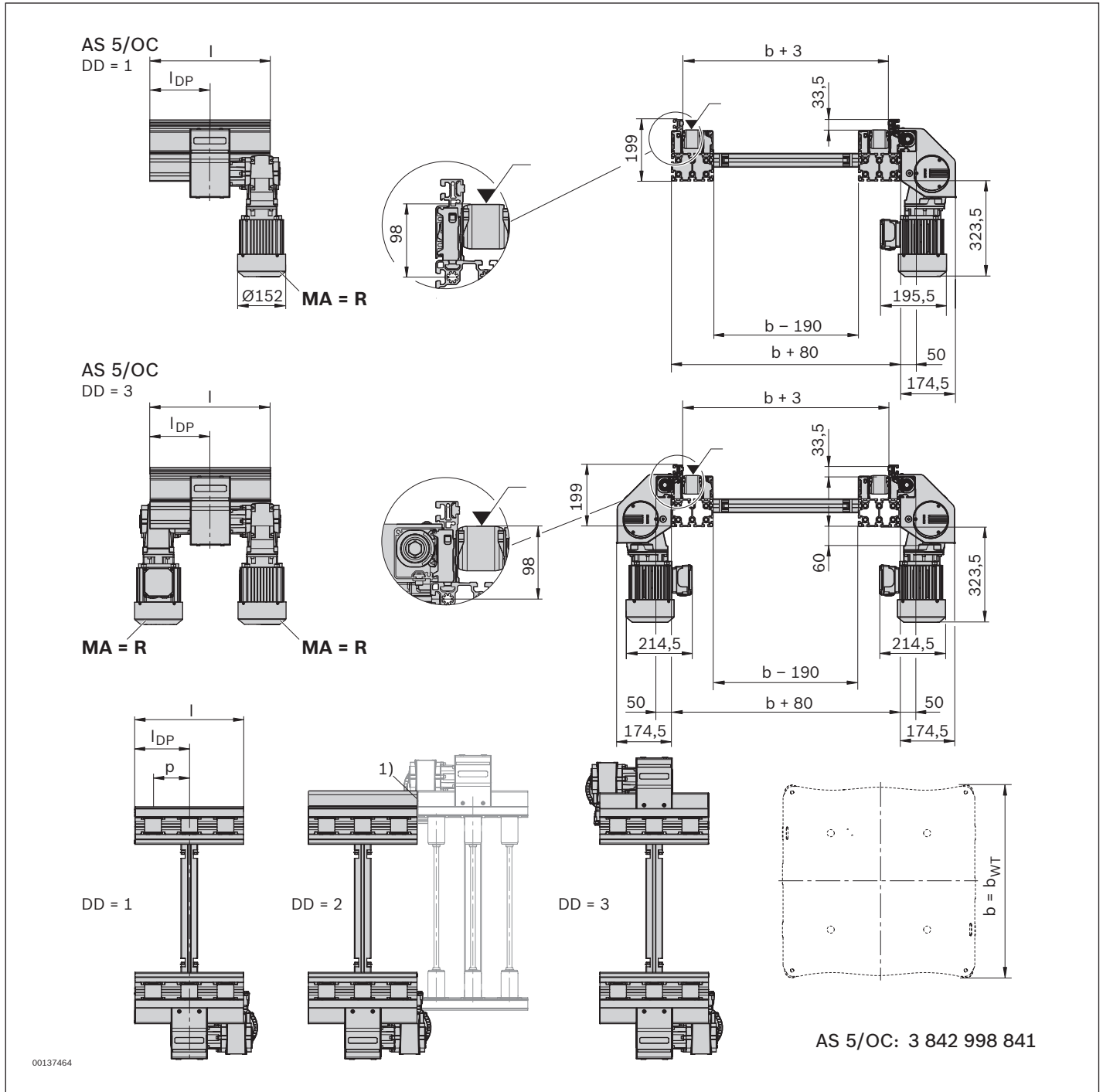

¹⁾ DD = 2: Join the drive side without the gear motor to a gear-driven section.

l = $p \times N$

l_{DP} = $DP \times p - p/2$

p = Roller spacing (pitch)

N = Number of rollers

DP = Drive position

Description of parameters, see page 3-15

Dimensions

Drive module AS 5/OC (Open Center), pitch $p = 195 \text{ mm}$; $p = 260 \text{ mm}$; $p = 325 \text{ mm}$

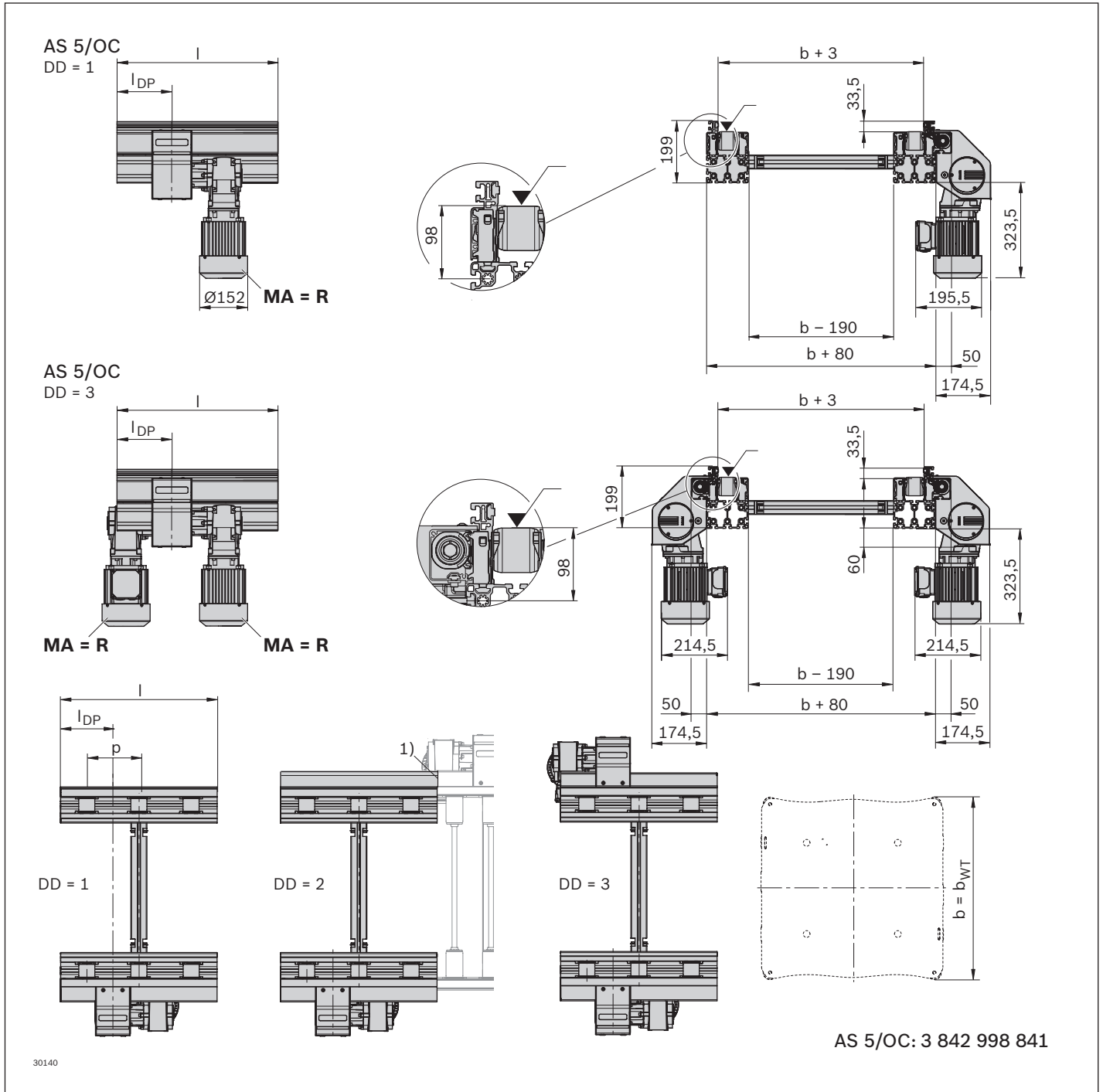

¹⁾ DD = 2: Join the drive side without the gear motor to a gear-driven section.

l = $p \times N$
 l_{DP} = $DP \times p$

p = Roller spacing (pitch)
 N = Number of rollers
 DP = Drive position

Description of parameters, see page 3-15

Pitch p and drive position DP

p = 130 mm

DP is the roller to which the transmission drive is fitted.
 This roller is not driven.

p = 195 mm; p = 260 mm; p = 325 mm

DP is the space between two rollers in which the transmission drive is fitted.

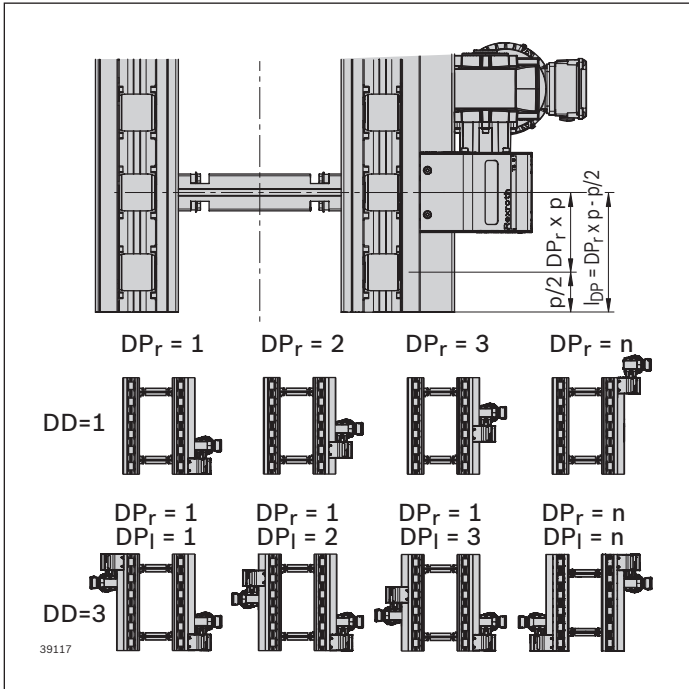

Example: DP = 2

Possible drive positions DP with pitch p

p (mm)	MA	DP
130	R; L	1 ... 31

Notice: Only if p = 130 mm:

Roller corresponding to DP is not driven.

Gear motor can be mounted on both sides.

Permissible position l_{DP} (mm) after start of section:

$$l_{DP} = DP \times p - p/2$$

Example for p = 130 mm and DP = 10:

$$l_{DP} = 10 \times 130 \text{ mm} - 65 \text{ mm} = 1235 \text{ mm}$$

Description of further parameters, see page 3-15

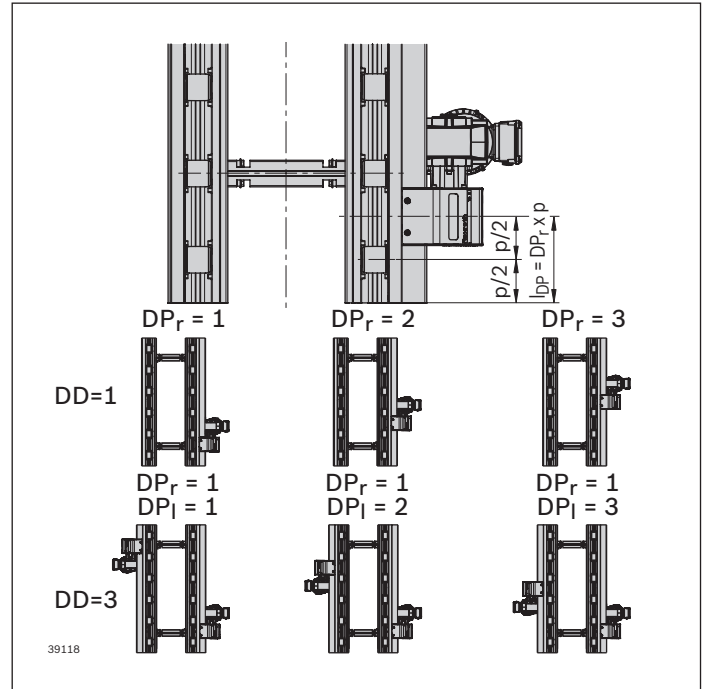

Example: DP = 1

Possible drive positions DP with pitch p

p (mm)	MA	DP
195	R; L	1 ... 20
260	R; L	1 ... 15
325	R; L	1 ... 11

Permissible position l_{DP} (mm) after start of section:

$$l_{DP} = DP \times p$$

Example for p = 260 mm and DP = 5:

$$l_{DP} = 5 \times 260 \text{ mm} = 1300 \text{ mm}$$

Drive options for an Open Center section

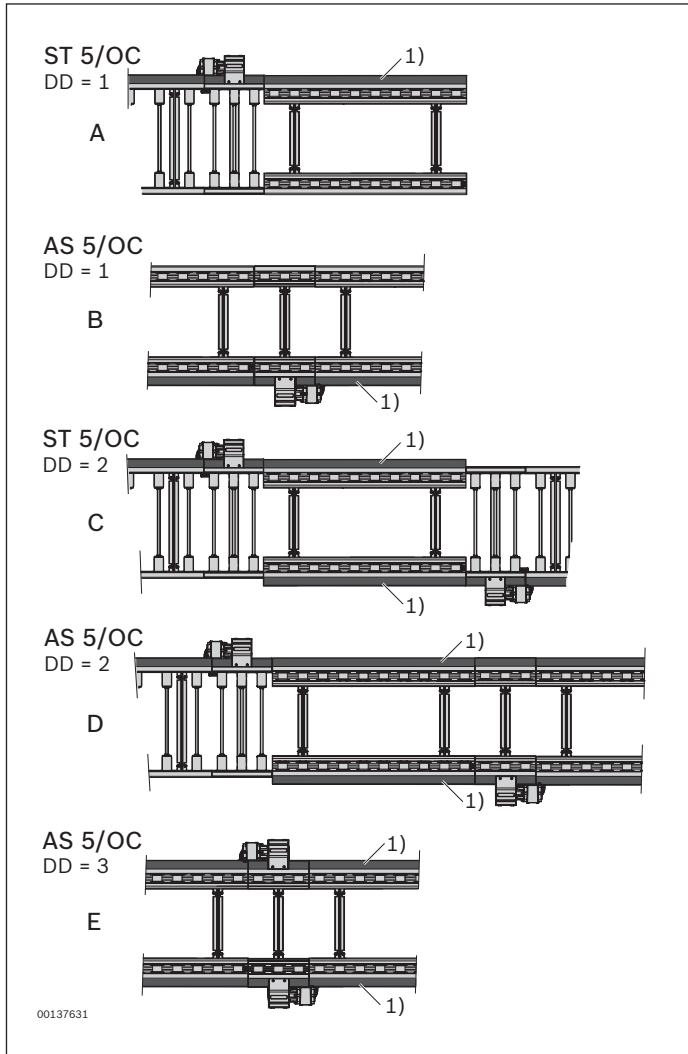

The TS 5 drive concept enables one- or two-sided drive of an Open Center section connected to adjacent sections. Depending on the loading situation, a separate drive AS 5/OC may not be required.

Load center of gravity within the permissible gravity center position

$b_{WT} \times l_{WT}$ (mm)	m_{WTmax} (kg)	DD =	m_{WTmax} (kg)	DD =
455 x 455	100	1 ²⁾	150	x ³⁾
455 x 650	160	1 ²⁾	250	x ³⁾
650 x 650	160	1 ²⁾	250	x ³⁾
650 x 845	200	1 ²⁾	300	x ³⁾
845 x 845	200	1 ²⁾	300	x ³⁾
845 x 1040	200	1 ²⁾	400	x ³⁾

²⁾ drive on one side sufficient (DD = 1)

³⁾ drive on both sides required (DD = 2 or DD = 3)

¹⁾ Drive side

A, B: Drive on one side

C, D, E: Drive on both sides

Selection of gear motor GM on AS 5

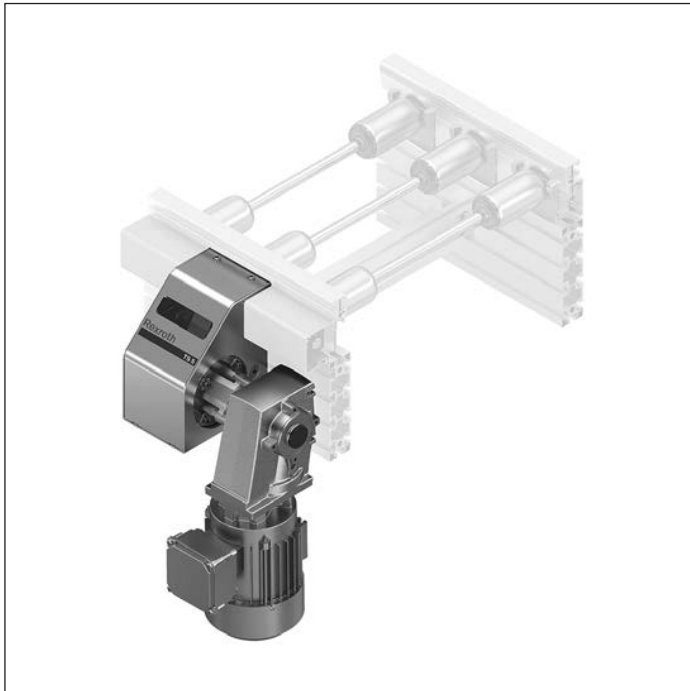

When ordering a drive module, you can choose between the installation of a gear motor or an interface for a separate motor.

You can choose from the following options:

GM = Gear motor

GM = 0: without (interface SW27)

GM = 1: with gear motor SW27

GM = 2: without (interface to connection SEW, round shaft $\varnothing 20$)

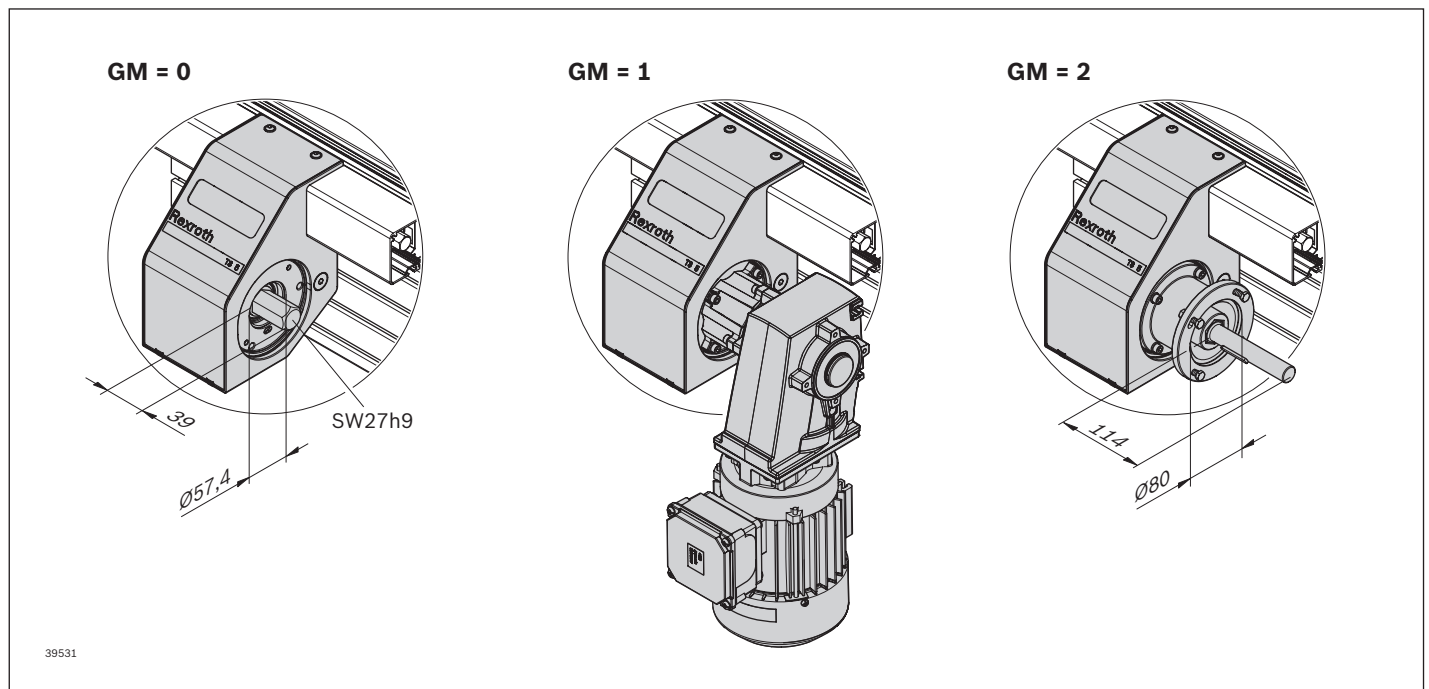

Drive kit AB 5

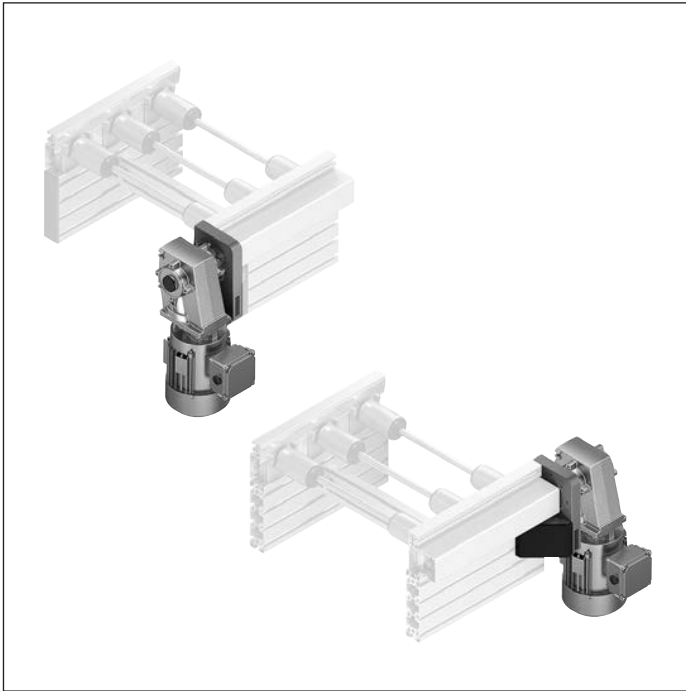

Scope of delivery

- ▶ Incl. fastening material and flange
- The corresponding section is not included in the scope of delivery

Material

- ▶ Flange (Lenze): Aluminum
- ▶ Flange (SEW): Steel
- ▶ Bracket: Aluminum
- ▶ Motor flange: Die-cast aluminum
- ▶ Shaft: Stainless steel
- ▶ Coupling: Cast steel, brass

Use

For face-side driving of

- ▶ Conveyor units ST 5/... and CU 5
- ▶ Adaptation of the sheet metal parts is required

Version

- ▶ Suitable for reversible operation (max. 20 Nm)
- ▶ With a Lenze gear motor (GM = 1) or with interface for installing a SEW gear motor (GM = 2)
- ▶ Motor connection with plug (AT = S) or terminal box (AT = K)
- ▶ Frequency converter, optional, see page 3-31

Notice:

- ▶ Maximum length of the driven total section at $p = 130$ and 45 Nm motor output = 19.5 m (longer sections on request)
- ▶ Suitable for driving two connected curves

Condition on delivery

- ▶ Not assembled
- Mounting option for the gear motor at the top/horizontally/bottom possible, see page 3-2

Ordering information

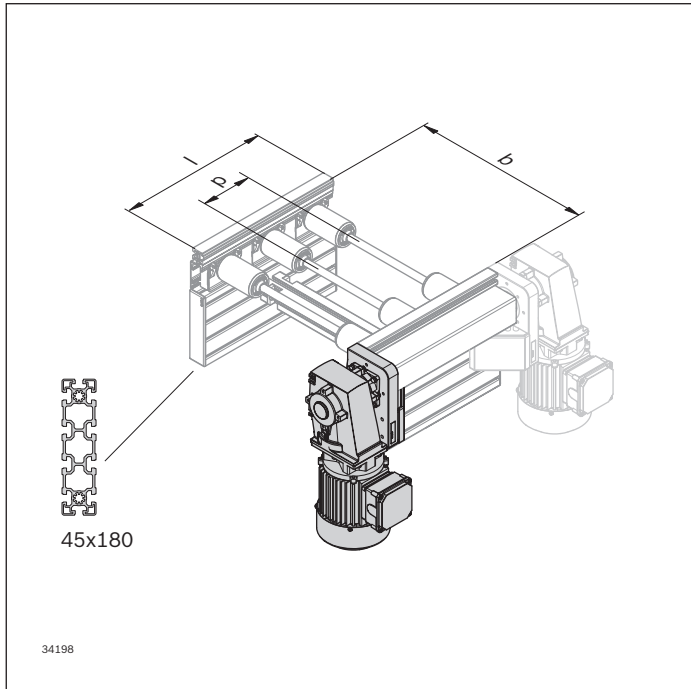

Drive kit AB 5

Material number		3 842 998 842
v_N (m/min)	Nominal speed	2*; 4*; 6; 9; 12; 15; 18 0: without gear motor
U (V)	Voltage	See motor data, p. 13-8
f (Hz)	Frequency	See motor data, p. 13-8
GM	Gear motor	0; 1; 2 0: without (interface SW27) 1: with gear motor SW27 2: without (interface to connection SEW, round shaft $\varnothing 20$)
AT	Motor connection	K; S K: with terminal box S: with plug
$p^{1)}$ (mm)	Roller spacing (pitch)	130; 195 ; 260; 325

* Additional measures may be necessary

¹⁾ Parameter p is only used to assign the last end plate
 Description of further parameters, see page 0-3

Dimensions
Drive kit AB 5

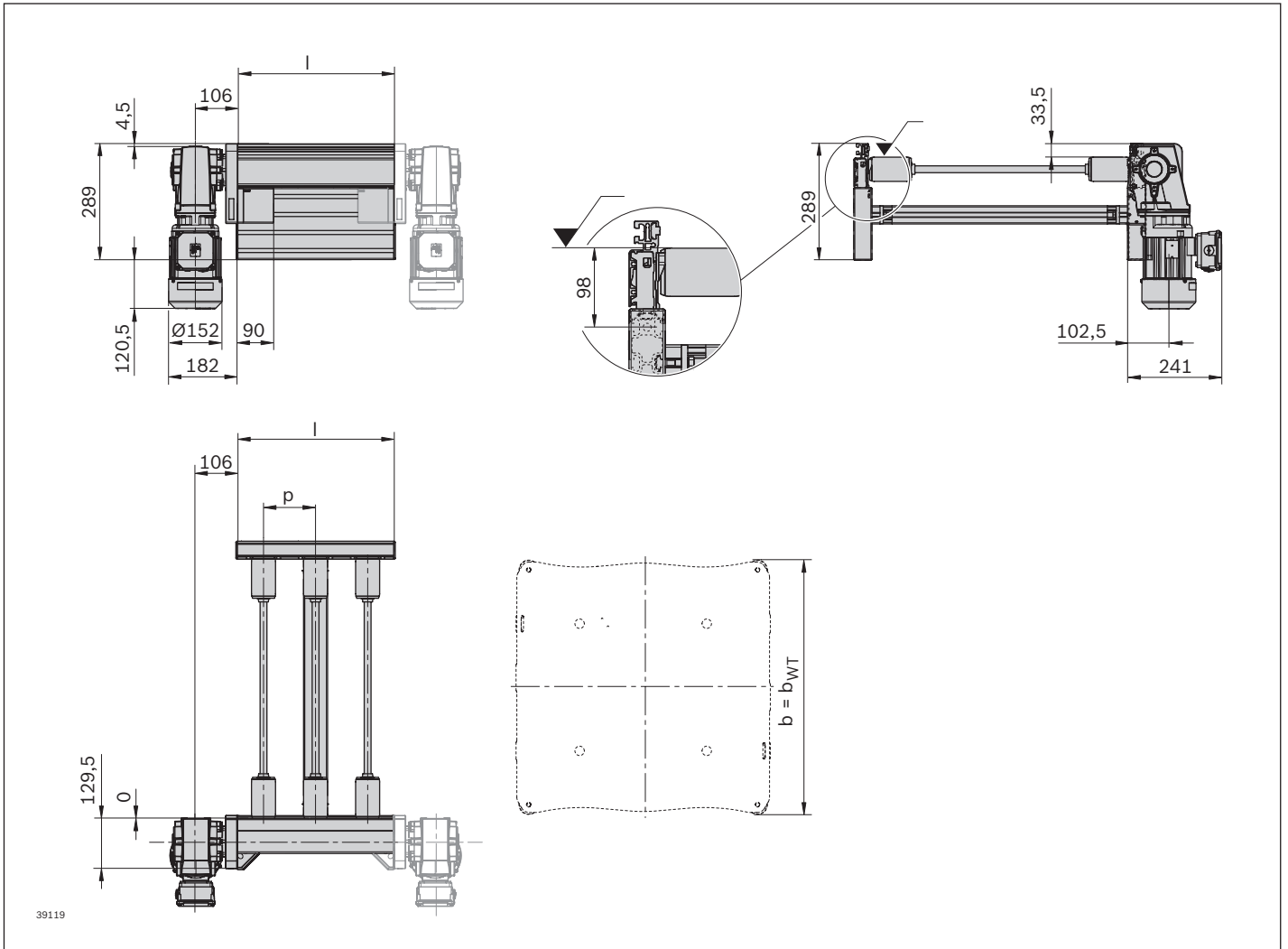

- I = $p \times N$
- p = Roller spacing (pitch)
- N = Number of rollers

Description of parameters, see page 0-3

End plates for AB 5 with ST 5/XH, ST 5/H, ST 5/XH-FR, ST 5/H-FR

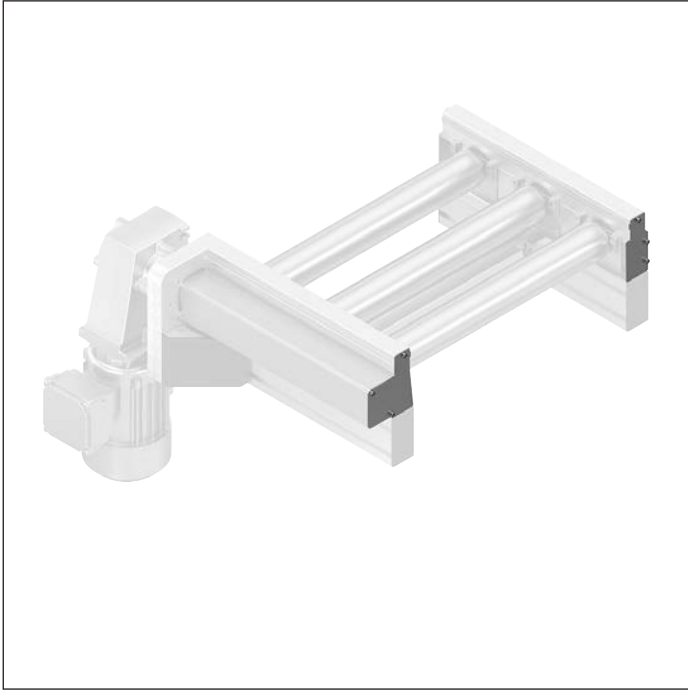

Use

- ▶ The protective covers and end plates are provided in working areas to increase safety

Notice: Do not walk on the protective covers or end plates.

Version

- ▶ Covers for section ends with AB 5

Material

- ▶ Anodized aluminum with microjoints for easy separation of the sheet metal

Ordering information

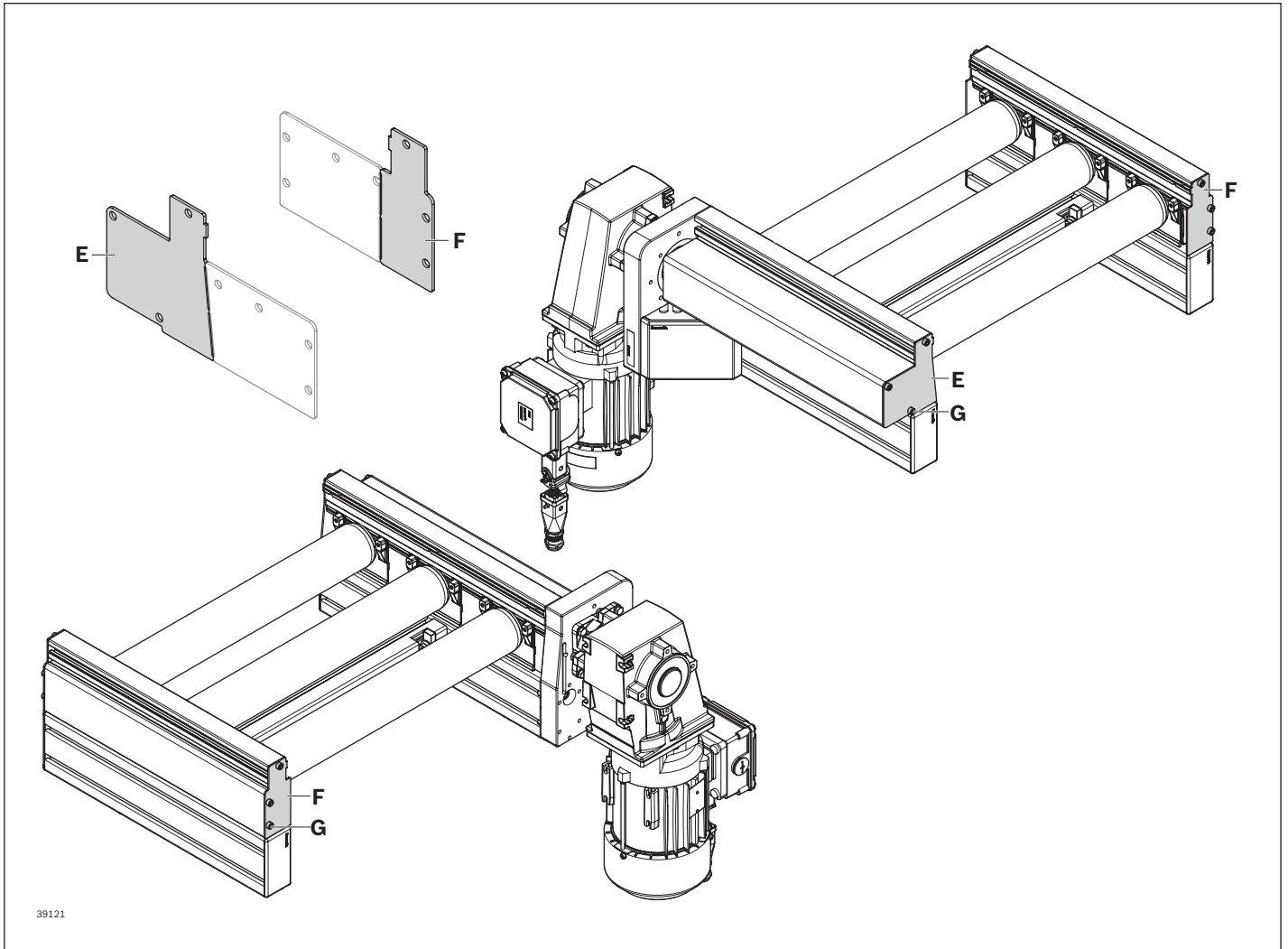

End plates

- ▶ End plate, drive side (**E**)
- ▶ End plate, for passive side (**F**)
- ▶ Screw (**G**) for fastening the end plate (**E/F**).

	Material number
E Drive side AB 5-OC	3 842 559 589
F Passive side AB 5-OC	3 842 559 590

Thread forming screws for end plates

		Material number
G	100	3 842 563 978

End plates for AB 5 with ST 5/OC

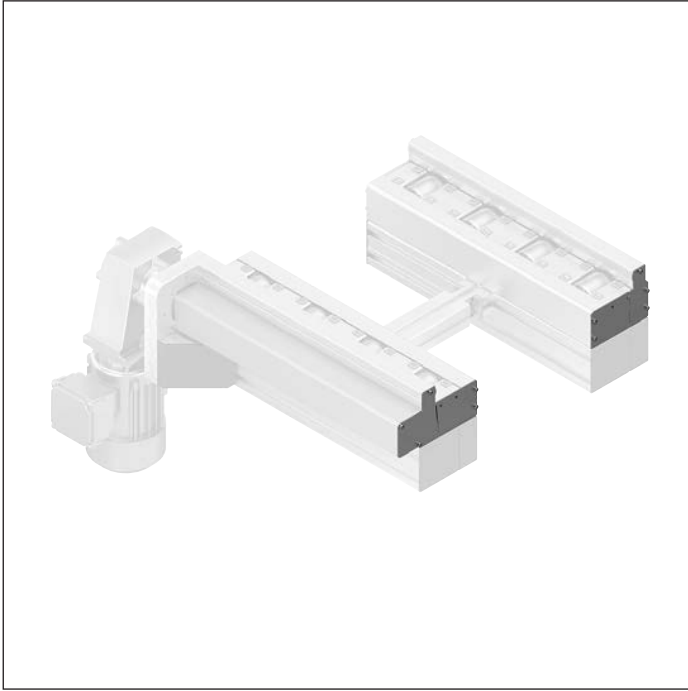

Use

- ▶ The protective covers and end plates are provided in working areas to increase safety

Notice: Do not walk on the protective covers or end plates.

Version

- ▶ Covers for section ends with AB 5

Material

- ▶ Anodized aluminum with microjoints for easy separation of the sheet metal

Ordering information

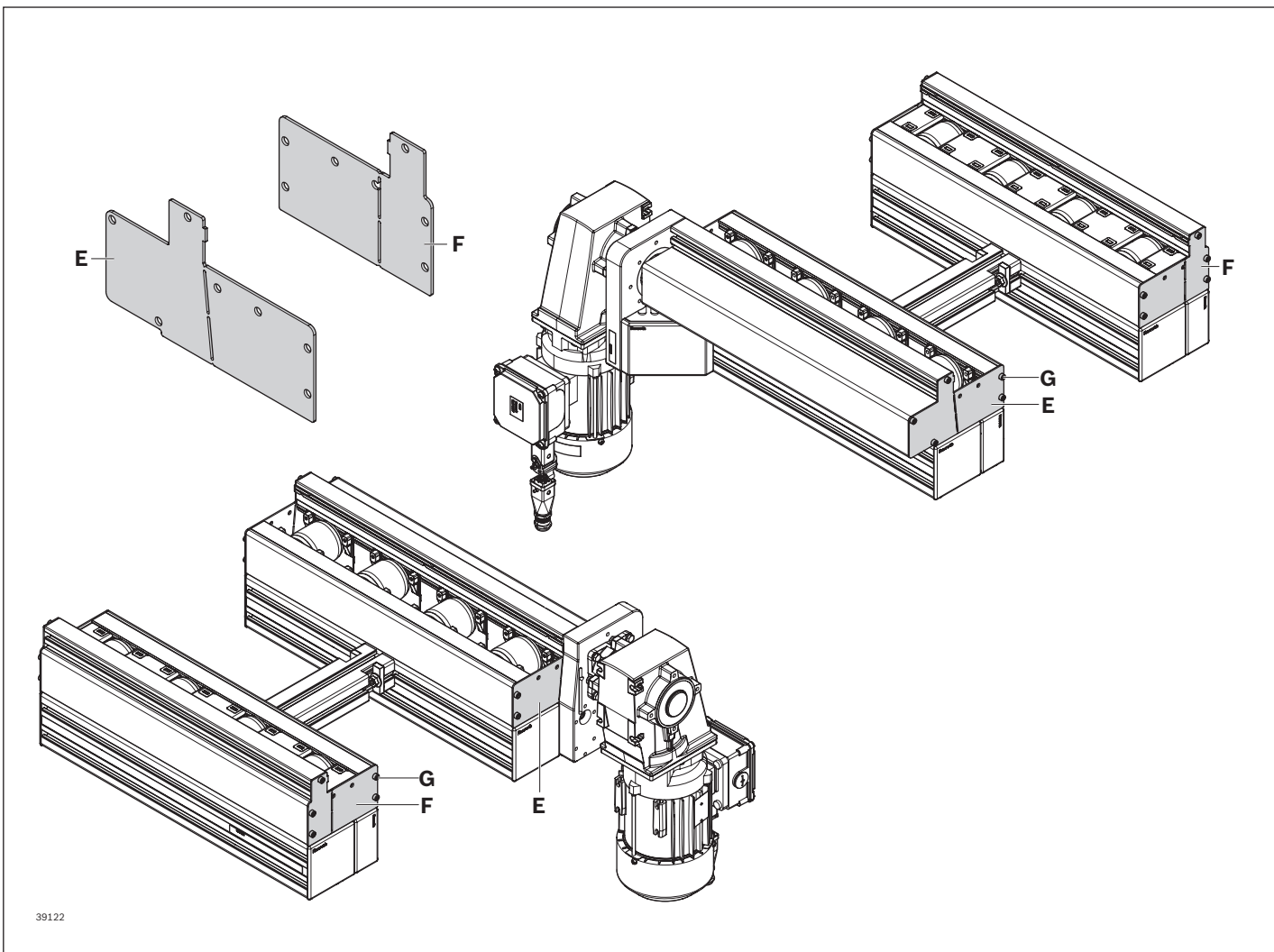

39122

End plates

- ▶ End plate, drive side (E)
- ▶ End plate, for passive side (F)
- ▶ Screw (G) for fastening the end plate (E/F).

Notice:

- ▶ If DD = 1, 1 end plate is required per side
- ▶ If DD = 2, 2 end plates (E) are required per side, but not the end plate (F)

	Material number
E Drive side AB 5-OC	3 842 559 589
F Passive side AB 5-OC	3 842 559 590

Thread forming screws for end plates

	🔩	Material number
G	100	3 842 563 978

Connection kit AB 5 on CU 5

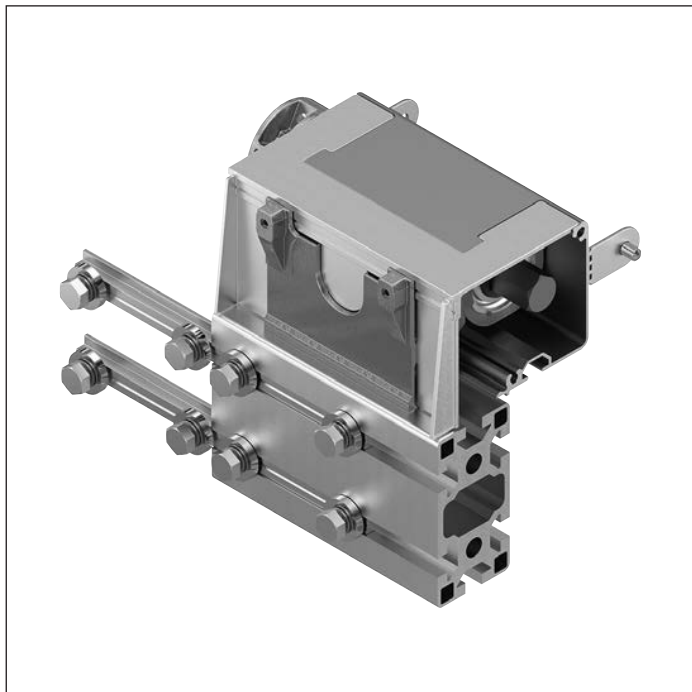

Use

The curve is a ready-for-operation module for branching transport of workpiece pallets. Curves can be driven either on the inside or on the outside. Instead of using an adjacent drive module, the curve can be driven using a drive kit AB 5.

Notice: A connection kit must be ordered for some configurations (see also page 3-29):

KR = 2; DSM = 2; DST = 2

KR = 2; DSM = 2; DST = 1

KR = 1; DSM = 1; DST = 1

KR = 1; DSM = 1; DST = 2

All other order examples can be assembled with the standard drive kit AB 5 (see page 3-21) without additional parts.

Connection kit AB 5 on CU 5

Material number

3 842 562 895

Condition on delivery

- Not assembled

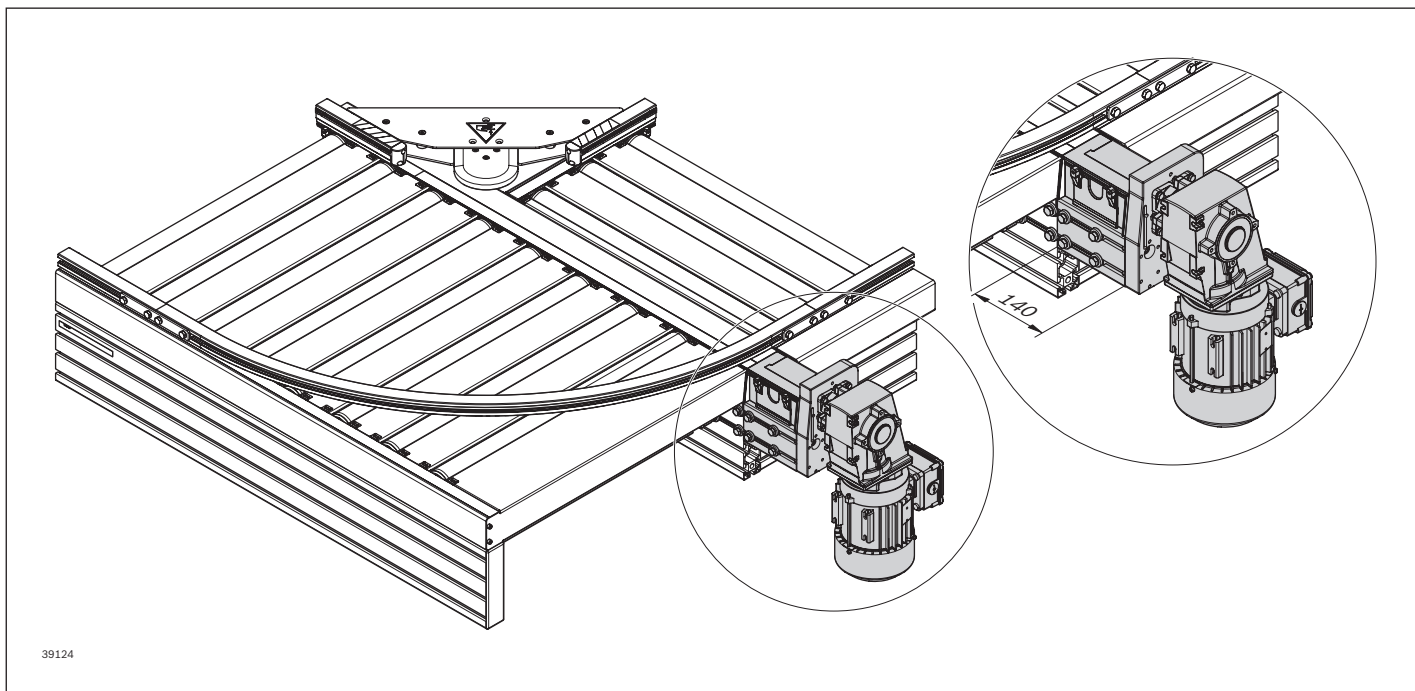

39124

Connection kit AB 5 on CU 5 order examples

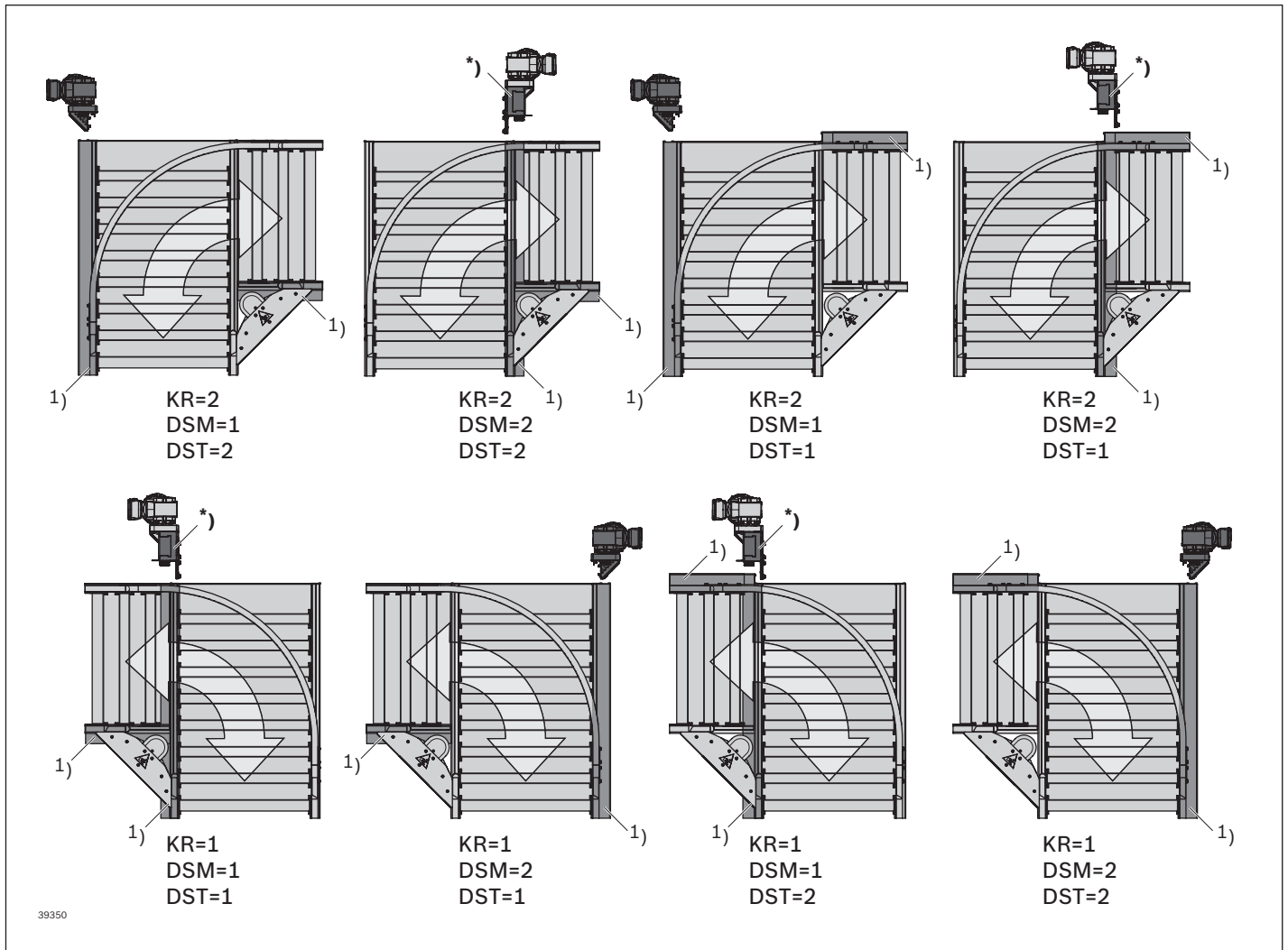

Selection of gear motor GM on AB 5

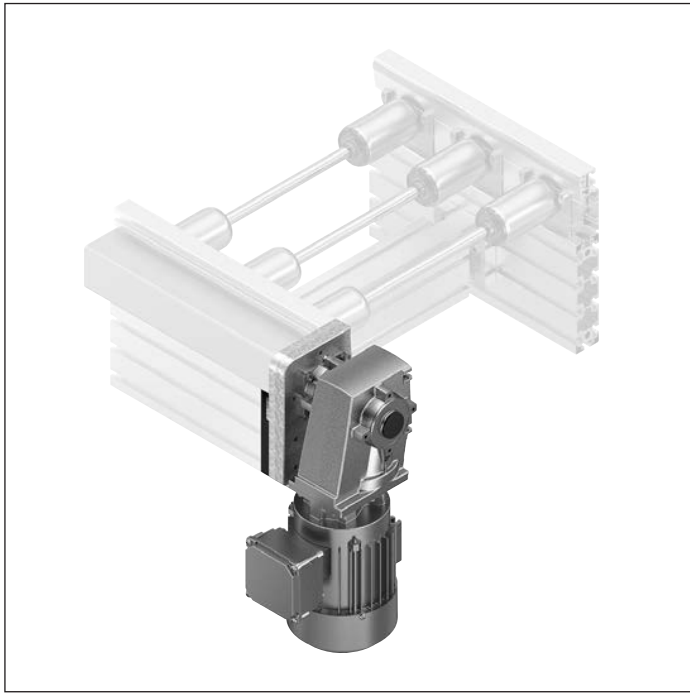

When ordering a drive kit, you can choose between the installation of a gear motor or an interface for a separate motor.

You can choose from the following options:

GM = Gear motor

0: without (interface SW27)

1: with gear motor SW27

2: without (interface to connection SEW, round shaft $\varnothing 20$)

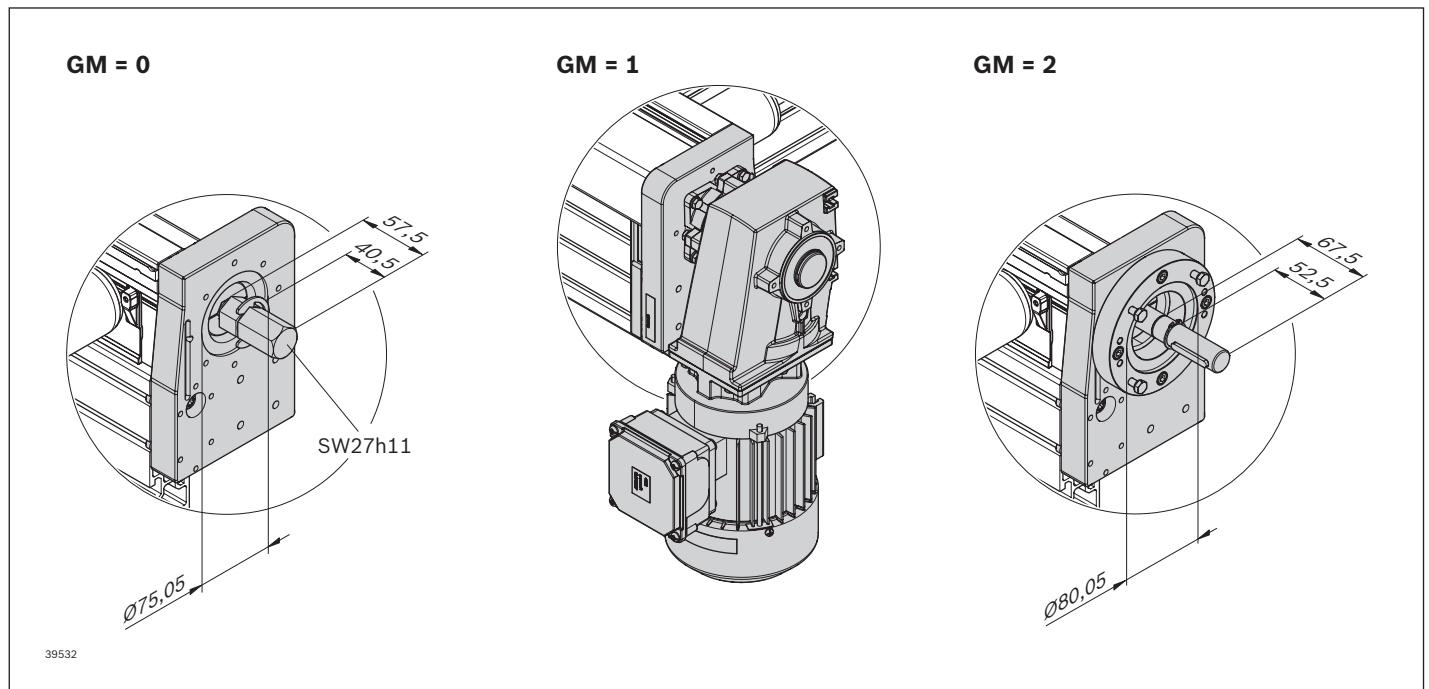

Frequency converter (FU)

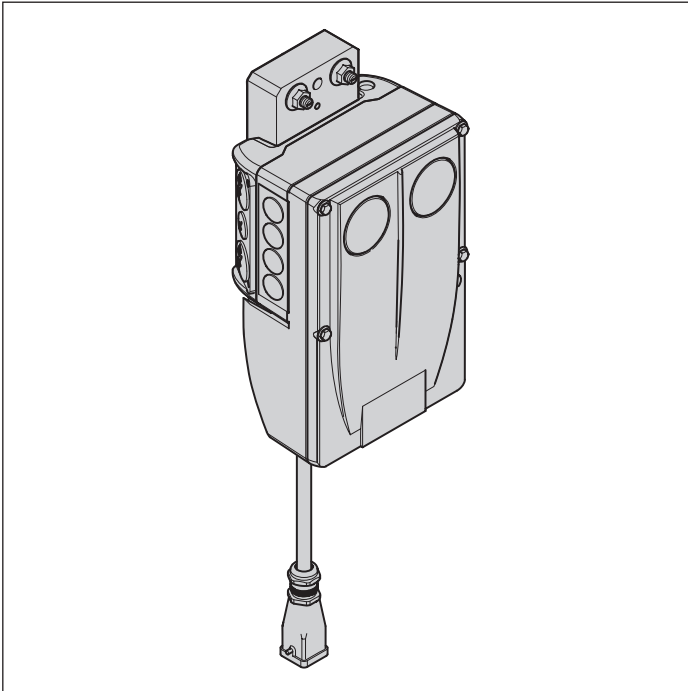

Required accessories

- ▶ Manual control unit, see page 3-35
- ▶ Switching/potentiometer unit, see page 3-35

In order to operate a gear motor with adjustable speed, the motor needs to be retrofitted with a frequency converter (FU). The frequency converter has a modular design so that it can be easily mounted on a leg set and connected to the motor by cable.

- Connection power: 0.55 kW (connection voltage: 400 V \pm 10% ... 460 V/480 V \pm 10%)
- Speed (v_N) depends on the base speed of the gear motor used

Permissible speed range: 2 ... 21 m/min

Complete frequency converter (FU) consisting of the modules

- Frequency converter power unit
- Communication module
- Connection unit
- Attachment kit
- Optional: Connection cable for the plug-in connection to the gear motor (AT = S)

The individual modules can be ordered separately and are easy to connect with the screws supplied with the scope of delivery. For the internal and external voltage supply, the modules must be wired by the user.

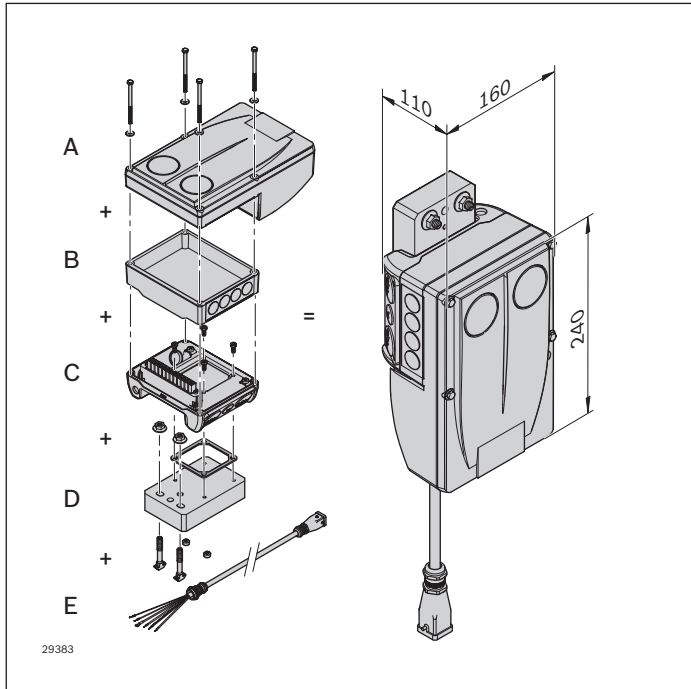

Complete frequency converter consisting of the modules

- ▶ Frequency converter power unit (**A**)
- ▶ Communication module (**B**)
- ▶ Connection unit (**C**)
- ▶ Attachment kit (**D**)
- ▶ Optional: Connection cable (**E**) for the plug-in connection to the gear motor (AT = S)

The individual modules can be ordered separately and are easy to connect with the screws supplied with the scope of delivery. For the internal and external voltage supply, the modules must be wired by the user (see terminal assignment plan, see page 13-12).

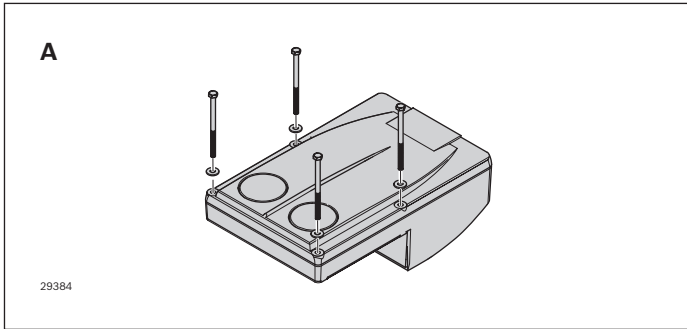

Frequency converter (A)

Power unit: 0.55 kW
(400 V ± 10% ... 460 V/480 V ± 10%)

- ▶ Easy start-up via hand-held terminal
- ▶ Easy-to-replace memory module
- ▶ Large LED status indicator

Product description	Material number
0.55 kW power unit	3 842 553 447

Motor speed range (m/min) at 50 Hz	Min (m/min)	Max (m/min)	Max (m/min) at max. 80% torque
4	2*	4.5	6
6	2*	6	8
9	3.5	10	13
12	4	13	17
15	5	15	20
18	6	18.5	25

The speed range of the frequency converter is based on the base speed of the motor¹⁾:

¹⁾ By accepting a resulting loss of power, a higher bandwidth can be covered (see page 13-11)

* Additional measures may be necessary

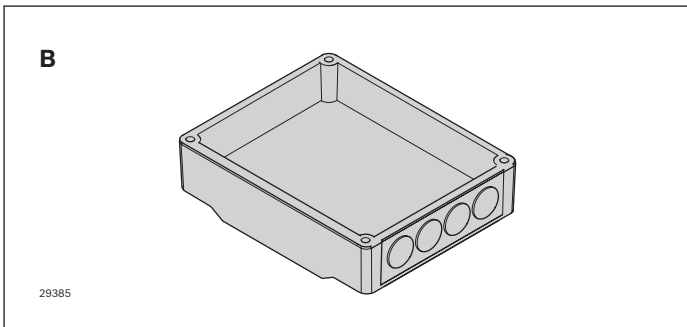

Communication module (B)

- ▶ Used to control the frequency converter
- ▶ Cable connection options

Depending on their function, the individual communication modules are provided with the corresponding connections.

Product description	Material number
Standard I/O	3 842 553 449
AS-i	3 842 553 453
CANopen	3 842 553 454
EtherNet/IP	3 842 553 451
EtherCAT	3 842 553 459
PROFIBUS	3 842 553 452
PROFINET	3 842 553 450

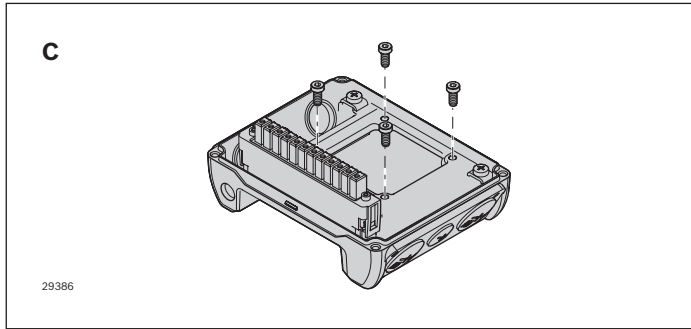

Connection unit (C)

- Power grid connection options

Product description	Material number
Connection unit	3 842 553 445

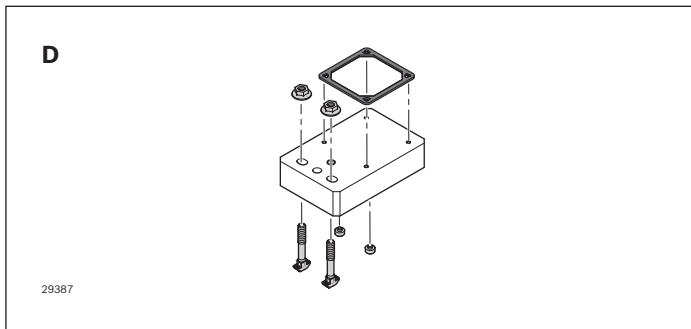

Attachment kit (D)

- For the simple attachment of the FU to the AL leg set (slot/s of a 60 or 80 strut profile)

Product description	Material number
Attachment kit	3 842 553 457

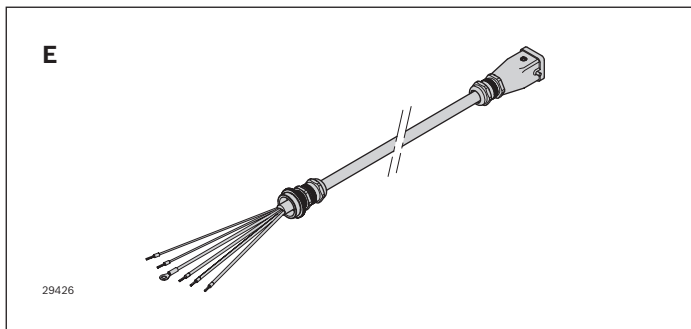

Connection cable (E)

- For connecting the gear motor to the frequency converter (length: 1 m)

Product description	Material number
Connection cable	3 842 553 512

Frequency converter (FU) accessories

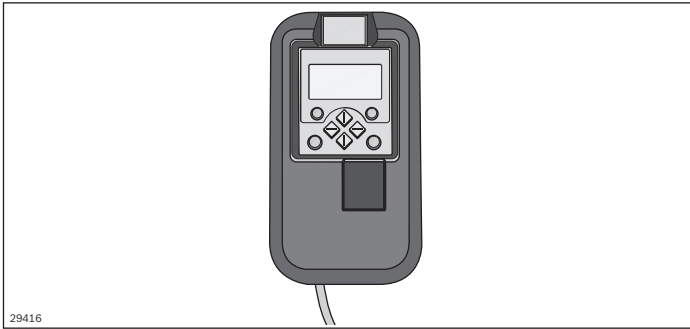

29416

Manual control unit (A)

The manual control unit is required for the parameterization of drives with frequency converters.

In addition, you can:

- ▶ Control (e.g. block and release)
- ▶ Display operating data
- ▶ Steplessly regulate the transport speed
- ▶ Transfer parameter sets to other basic devices

Product description	Material number
Manual control unit	3 842 552 821

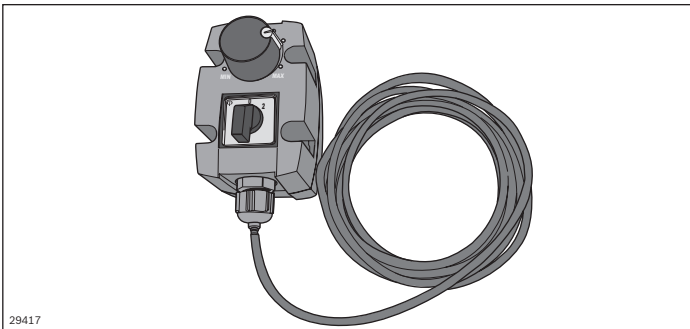

29417

Switch/potentiometer unit (B)

The switching/potentiometer unit is used to fine tune the transport speed within a range that has been preset with the manual control unit. The switching/potentiometer unit is connected to the frequency converter by a cable. The drive can be started or stopped with the rotary switch.

Notice: It is imperative that the running direction of the roller conveyor is checked prior to commissioning.

Product description	Material number
Switching/potentiometer unit	3 842 553 184

Scope of delivery

A, B: Incl. 2.5 m connection cable

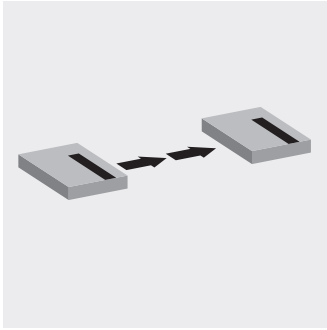

Longitudinal conveyor

4

Selection of conveyor units	4-2
Conveyor units ST 5/XH, ST 5/H (with split rollers)	4-3
End plates for ST 5/XH, ST 5/H	4-6
Protective covers for ST 5/XH, ST 5/H	4-8
Conveyor units ST 5/XH-FR, ST 5/H-FR (with full rollers)	4-10
End plates for ST 5/XH-FR, ST 5/H-FR	4-13
Protective covers for ST 5/XH-FR, ST 5/H-FR	4-15
Conveyor units ST 5/OC (Open Center)	4-17
End plates for ST 5/OC	4-20
Protective covers for ST 5/OC	4-22
Cover for transition OC/XH, OC/H	4-23
Connection kits	4-25

Selection of conveyor units

Application and functions

Conveyor units are available in 2 load classes and 3 different system widths (455, 650, 845 mm) for longitudinal conveyors, as well as a further width for transverse conveyors (1040 mm). All rollers in the conveyor unit are driven by a king shaft in the respective drive unit. The king shaft is located behind a protective cover below the transport level; the workpiece pallet can pass over the king shaft.

The conveyor units have a symmetrical design and there is no drive side selection.

The rollers are driven by bevel wheels; a friction clutch protects the drive during accumulation operation.

2 roller types:

- ▶ Split rollers as standard for longitudinal conveyors
- ▶ Full rollers (FR) as standard for curves, diverters, and junctions
- ▶ Full rollers for longitudinal conveyors to transport workpieces without workpiece pallets
- ▶ Open Center for easy access from below
- ▶ All roller types can be used in the transverse conveyor

Notice: The use of conveyor units with full rollers with WTs is limited. Depending on the roller dimensions, it may not be possible to assemble stop gates, sensor supports, and supports for ID systems due to insufficient space.

Required accessories

- ▶ Drive unit AS 5/..., see page 3-1
- ▶ Leg sets SZ 5/..., see page 7-1
- ▶ Connection kits, see page 4-25

Conveyor unit load capacity

- ▶ Permissible section load with a leg distance ≤ 2 m:
 - ST 5/XH: 380 kg/m
 - ST 5/H: 200 kg/m

Permitted loads apply under the condition that only workpiece pallets with the maximum WT total weight permitted m_G have accumulated.

Accumulation operation is not permitted in curves, diverters, junctions, or the positioning unit.

Max. permissible WT total weight m_G with different WT lengths and roller spacings (division p)

When designing the transfer system, the WT length, WT total weight m_G and roller spacing (pitch p) must be adjusted to each other.

The carrying force per roller is 50 kg. The WT must always be on at least 3 rollers. The resulting load limits are shown in the graphic (see page 2-8).

Use of the customer's own workpiece pallets

The indicated interdependencies between b_{WT} and l_{WT} must be taken into account when using curves, diverters and lift transverse units.

If a WT is only conveyed on a straight section, it can be any length; observe the permissible section load and load per roller. The WT total weight m_G can also be more than 400 kg for longitudinal conveyor at the customer's WTs.

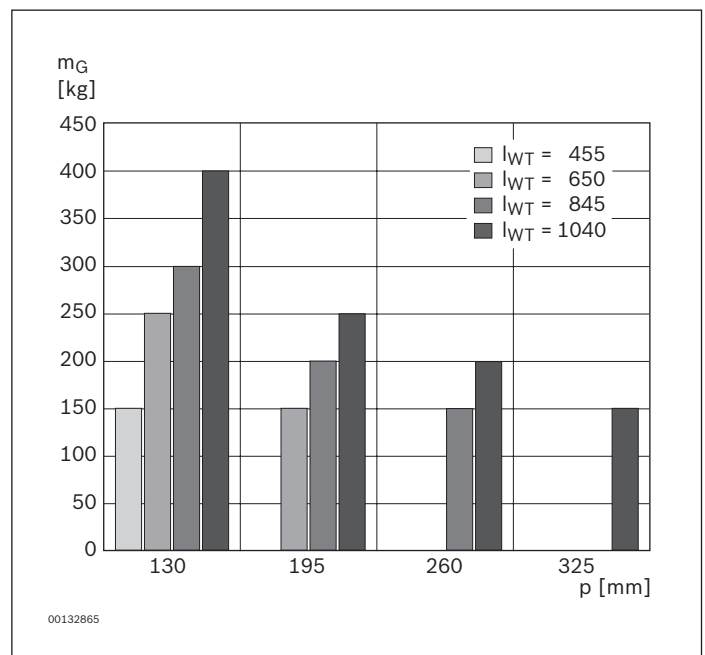

m_G = WT total weight

p = roller spacing

Conveyor units ST 5/XH, ST 5/H (with split rollers)

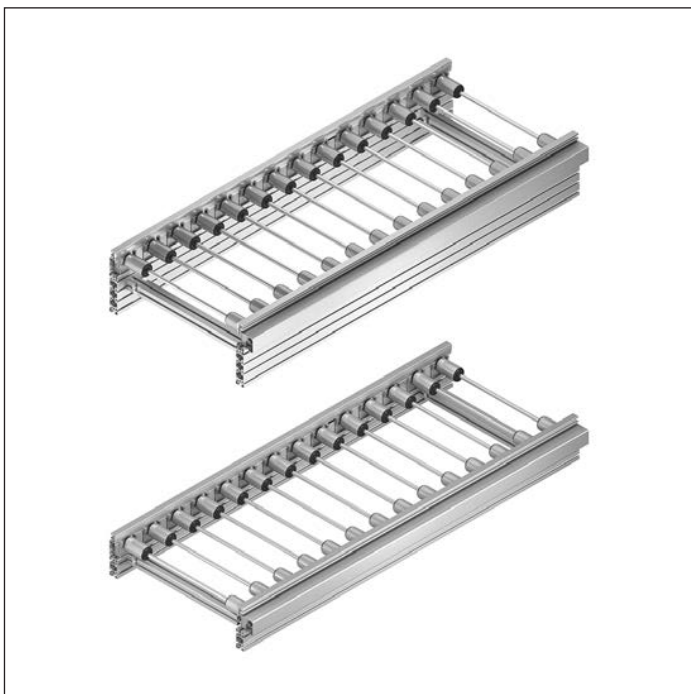

Condition on delivery

- ▶ Ready-to-install

Use

- ▶ The conveyor unit is a ready-for-operation module used to transport workpiece pallets

Version

- ▶ Reversible operation possible
- ▶ Accumulation operation possible
- ▶ Support profile made of anodized aluminum
- ▶ Permissible section load:
 - ST 5/XH: 380 kg/m
 - ST 5/H: 200 kg/m
- ▶ Lateral guide profile made of steel, plastic, or aluminum in an anodized aluminum support
- ▶ Driven via king shaft with bevel wheels made of plastic or sintered metal
- ▶ Suitable for cleanroom of ISO class 7
- ▶ Suitable for dry room <1% RH

Notice: Other roller spacings available on request.

Ordering information

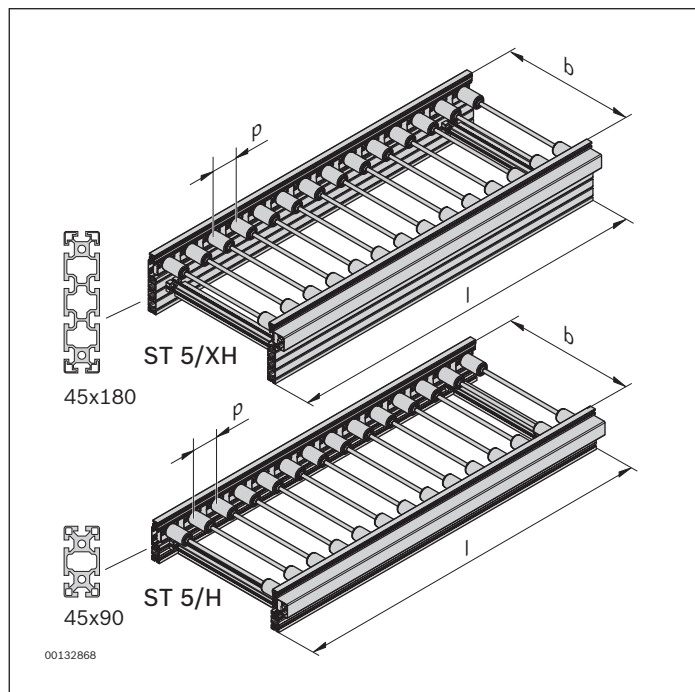

Conveyor units ST 5/XH, ST 5/H

Product description	Material number
ST 5/XH	3 842 998 521
ST 5/H	3 842 998 520
	b = ... mm
	l_{WT} = ... mm
	p = ... mm
	l = ... mm
	LG = ...
	BG = ...
	TR = ...

Conveyor units ST 5/XH, ST 5/H

b (mm)	l_{WT} (mm)	p (mm)	l (mm)	N	LG	BG	TR
455	455; 650	130	390 ... 4160	3; 4; 5 ... 32	1; 2; 3	1; 2	1; 2
455	650	195	585 ... 4095	3; 4; 5 ... 21	1; 2; 3	1; 2	1; 2
650	650; 845	130	390 ... 4160	3; 4; 5 ... 32	1; 2; 3	1; 2	1; 2
650	650; 845	195	585 ... 4095	3; 4; 5 ... 21	1; 2; 3	1; 2	1; 2
650	845	260	780 ... 4160	3; 4; 5 ... 16	1; 2; 3	1; 2	1; 2
845	845; 1040	130	390 ... 4160	3; 4; 5 ... 32	1; 2; 3	1; 2	1; 2
845	845; 1040	195	585 ... 4095	3; 4; 5 ... 21	1; 2; 3	1; 2	1; 2
845	845; 1040	260	780 ... 4160	3; 4; 5 ... 16	1; 2; 3	1; 2	1; 2
845	1040	325	975 ... 3900	3; 4; 5 ... 12	1; 2; 3	1; 2	1; 2
1040	845	130	390 ... 4160	3; 4; 5 ... 32	1; 2; 3	1; 2	1; 2
1040	845	195	585 ... 4095	3; 4; 5 ... 21	1; 2; 3	1; 2	1; 2
1040	845	260	780 ... 4160	3; 4; 5 ... 16	1; 2; 3	1; 2	1; 2

b = Track width
 l_{WT} = Workpiece pallet length, note the interdependencies for p and l_{WT} !
 p = Roller spacing (pitch)
 l = Length graduated according to the roller dimensions ($l = p \times N$)

N = Number of rollers, multiplier for length ($l = p \times N$), pricing factor in the price list
 LG = Lateral guide material
 1: Steel
 2: Plastic
 3: Aluminum

BG = Bevel wheel material
 1: Plastic
 2: Sintered metal
 TR = Roller material
 1: Steel, galvanized
 2: Steel, nitrocarburized

Dimensions

Conveyor unit ST 5/XH, ST 5/H

ST 5/XH

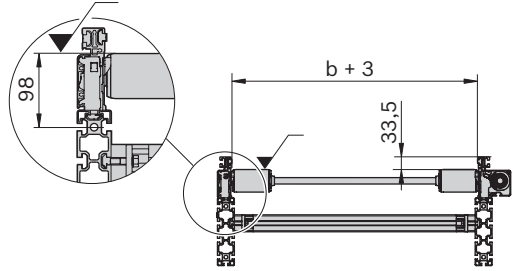
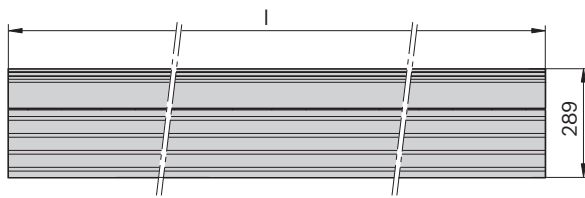

ST 5/H

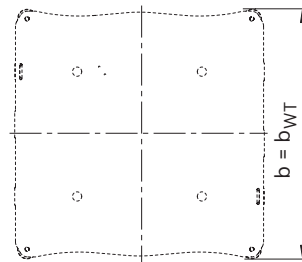
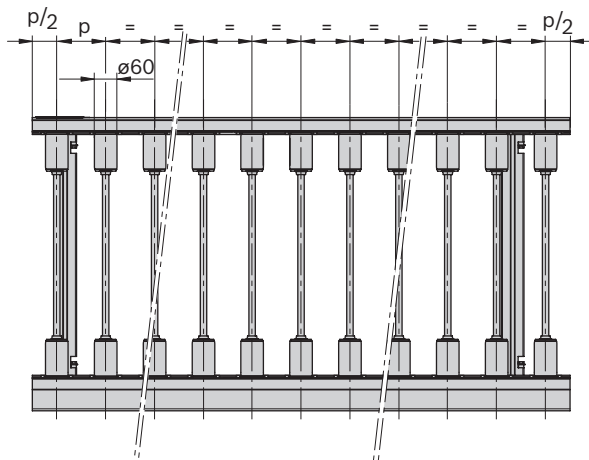
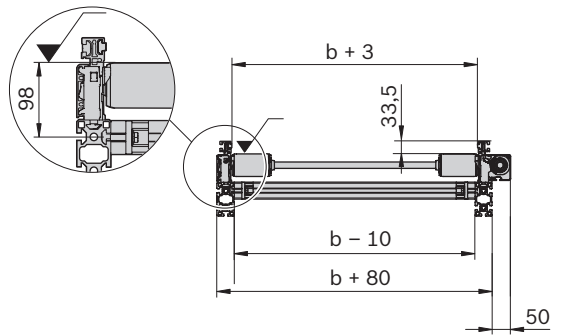
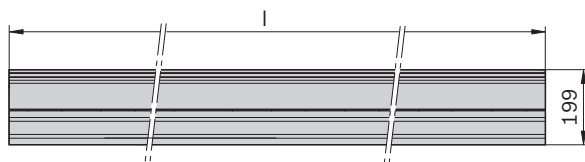

ST 5/XH: 3 842 998 521
 ST 5/H: 3 842 998 520

00132888

End plates for ST 5/XH, ST 5/H

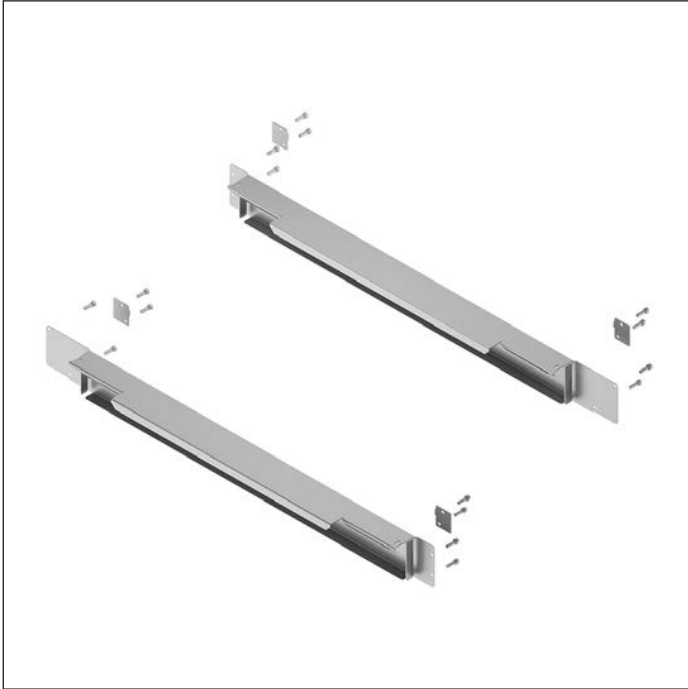

Use

- ▶ The protective covers and end plates are provided in working areas to increase safety. They can be ordered separately for conveyor units; for curves, diverters, and junctions they are optionally included in the scope of delivery (SC = 2)
- ▶ The protective covers and end plates are clipped between the rollers using spring elements

Notice: Do not walk on the protective covers or end plates.

Versions

- ▶ Protective covers for various widths and roller spacings.
- ▶ Special covers for conveyor section center, transitions, and ends.

Material

- ▶ Steel, galvanized

Ordering information

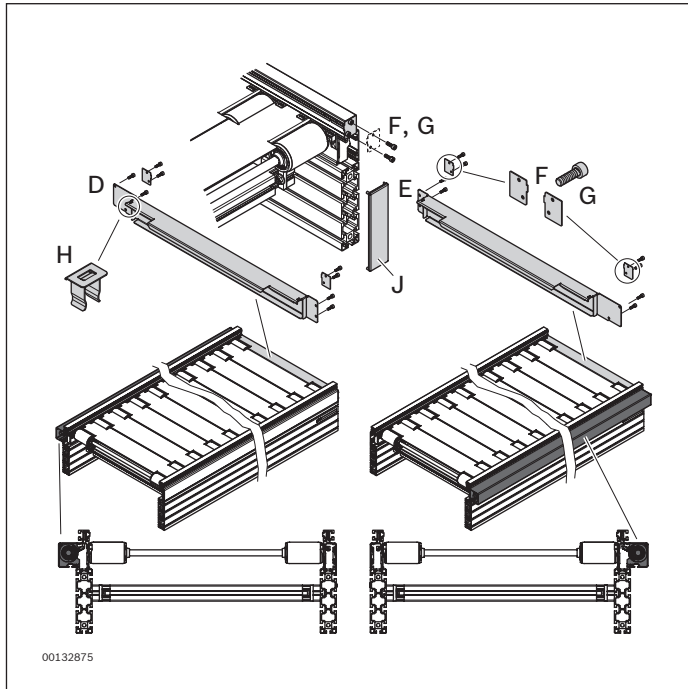

End plates

- ▶ End plate, left drive side (**D**)
- ▶ End plate, right drive side (**E**)

	b (mm)	p (mm)	Material number
D	455	130	3 842 545 679
	455	195	3 842 545 680
	650	130	3 842 545 681
	650	195	3 842 545 682
	650	260	3 842 545 683
	845	130	3 842 545 684
	845	195	3 842 545 685
	845	260	3 842 545 686
	845	325	3 842 545 687
	1040	130	3 842 545 476
E	455	130	3 842 545 689
	455	195	3 842 545 690
	650	130	3 842 545 691
	650	195	3 842 545 692
	650	260	3 842 545 693
	845	130	3 842 545 694
	845	195	3 842 545 695
	845	260	3 842 545 696
	845	325	3 842 545 697
	1040	130	3 842 545 474
1040	195	3 842 545 475	
1040	260	3 842 545 698	

b = Track width
p = Roller spacing

Lateral guide cover

- ▶ Lateral guide protective cover (**F**), 2 required

		Material number
F	2	3 842 545 276

Thread forming screw

- ▶ Screw (**G**), 4 required for each end plate (**D/E**) and 2 for each lateral guide cover (**F**)

		Material number
G	100	3 842 563 978

Spring element

- ▶ Spring element (**H**), 2 required for each end plate

		Material number
H	50	3 842 545 214

Cover caps

- ▶ Cover cap for the open profile ends (**J**), 2 required for each section end

			Material number
J	ST 5/XH (45x180)	20	3 842 503 845
	ST 5/H (45x90)	20	3 842 511 783

Protective covers for ST 5/XH, ST 5/H

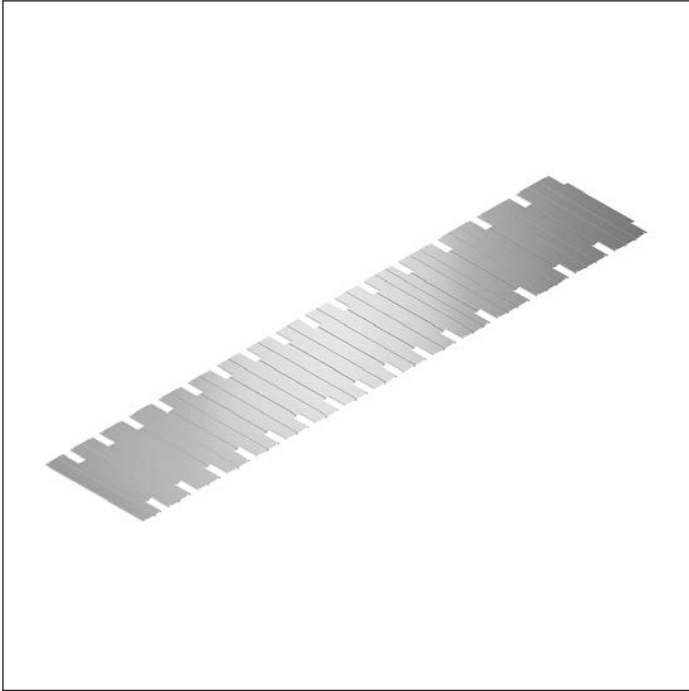

- ▶ Section center protective cover (**A**)
- ▶ Protective covers for transition between curve (diverter, junction) / conveyor unit (**B**)
- ▶ Protective covers for transition between conveyor unit/conveyor unit with different rollers (**C**)
- ▶ Spring element (**H**), 4 required for each protective cover, see page 4-9

The different dimensions of the protective covers can be found on page 4-9.

Ordering information

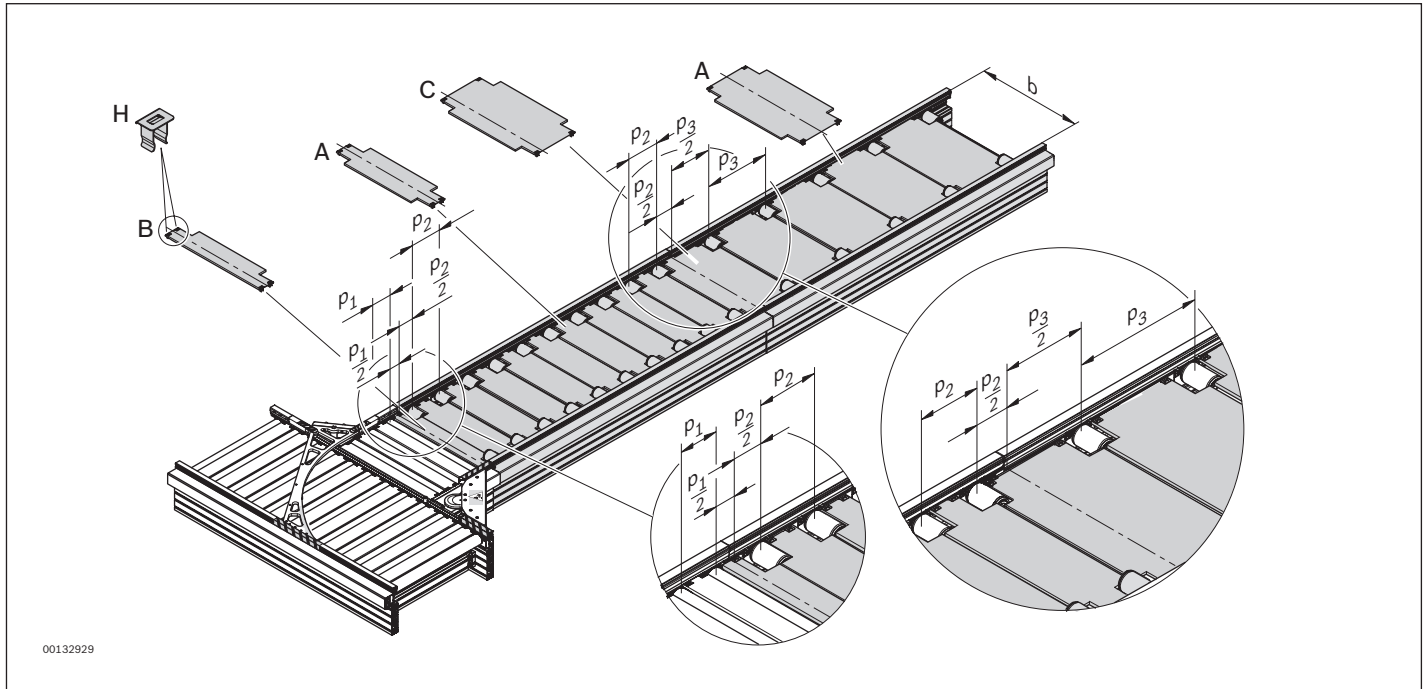

Protective covers for section center (A) and transitions (B, C)

	b (mm)	p (mm)	Material number
A	455	130	3 842 545 404
	455	195	3 842 545 609
	650	130	3 842 545 405
	650	195	3 842 545 360
	650	260	3 842 545 612
	845	130	3 842 545 361
	845	195	3 842 545 362
	845	260	3 842 545 363
	845	325	3 842 545 403
	1040	130	3 842 545 638
	1040	195	3 842 545 641
	1040	260	3 842 545 365

	b (mm)	p1/p2 (mm)	Material number
B	455	130/130	3 842 545 482
	455	130/195	3 842 545 617
	650	130/130	3 842 545 483
	650	130/195	3 842 545 485
	650	130/260	3 842 545 621
	845	130/130	3 842 545 484
	845	130/195	3 842 545 506
	845	130/260	3 842 545 507
	845	130/325	3 842 545 508

b = Track width
 p = Roller spacing (pitch); p1/p2 and p2/p3
 = Transition between different roller spacing dimensions

	b (mm)	p2/p3 (mm)	Material number
C	455	130/195	3 842 545 616
	650	130/195	3 842 545 619
	650	195/260	3 842 545 644
	845	130/195	3 842 545 628
	845	195/260	3 842 545 629
	845	260/325	3 842 545 645
	1040	130/195	3 842 545 640
	1040	195/260	3 842 545 364

b = Track width
 p = Roller spacing (pitch); p1/p2 and p2/p3
 = Transition between different roller spacing dimensions

Spring element

► Spring element (H), 2 required for each end plate

		Material number
H	50	3 842 545 214

Conveyor units ST 5/XH-FR, ST 5/H-FR (with full rollers)



Condition on delivery

- ▶ Ready-to-install

Use

- ▶ The conveyor unit is a ready-for-operation module, which is particularly suitable for transporting workpieces without workpiece pallets

Notice: Depending on the roller spacing, the use of conveyor units ST 5/...-FR with WT is limited, see page 4-2. Other roller spacings available on request.

Version

- ▶ Reversible operation possible
- ▶ Accumulation operation possible
- ▶ Support profile made of anodized aluminum
- ▶ Permissible section load:
 - ST 5/XH-FR: 380 kg/m
 - ST 5/H-FR: 200 kg/m
- ▶ Lateral guide profile made of steel, plastic, or aluminum in an anodized aluminum support
- ▶ Driven via king shaft with bevel wheels made of plastic or sintered metal
- ▶ Suitable for cleanroom of ISO class 7
- ▶ Suitable for dry room <1% RH

Ordering information

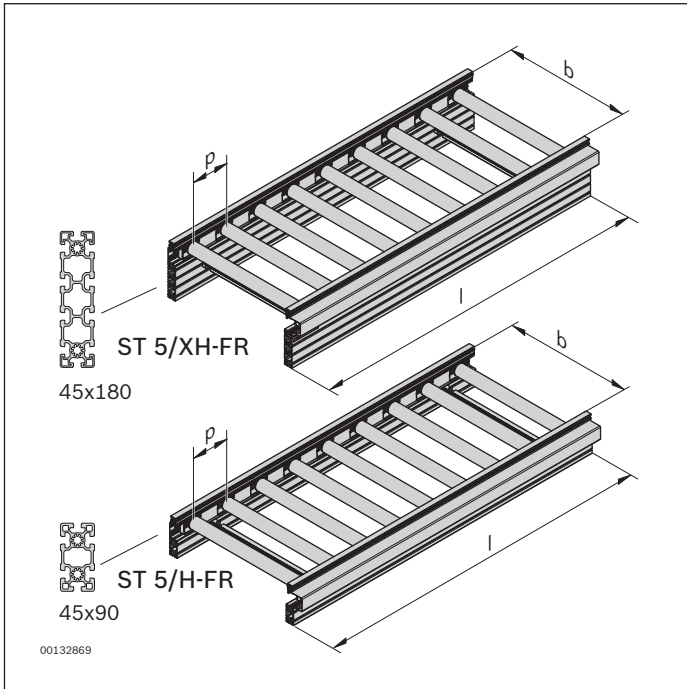

Conveyor units ST 5/XH-FR, ST 5/H-FR

Product description	Material number
ST 5/XH-FR	3 842 998 523
ST 5/H-FR	3 842 998 522
	b = ... mm
	$l_{WT} = \dots$ mm
	p = ... mm
	l = ... mm
	LG = ...
	BG = ...
	TR = ...

4

Conveyor units ST 5/XH-FR, ST 5/H-FR

b (mm)	l_{WT} (mm)	p (mm)	l (mm)	N	LG	BG	TR
455	455; 650	130	390 ... 4160	3; 4; 5 ... 32	1; 2; 3	1; 2	1; 2
455	650	195	585 ... 4095	3; 4; 5 ... 21	1; 2; 3	1; 2	1; 2
650	650; 845	130	390 ... 4160	3; 4; 5 ... 32	1; 2; 3	1; 2	1; 2
650	650; 845	195	585 ... 4095	3; 4; 5 ... 21	1; 2; 3	1; 2	1; 2
650	845	260	780 ... 4160	3; 4; 5 ... 16	1; 2; 3	1; 2	1; 2
845	845; 1040	130	390 ... 4160	3; 4; 5 ... 32	1; 2; 3	1; 2	1; 2
845	845; 1040	195	585 ... 4095	3; 4; 5 ... 21	1; 2; 3	1; 2	1; 2
845	845; 1040	260	780 ... 4160	3; 4; 5 ... 16	1; 2; 3	1; 2	1; 2
845	1040	325	975 ... 3900	3; 4; 5 ... 12	1; 2; 3	1; 2	1; 2
1040	845	130	390 ... 4160	3; 4; 5 ... 32	1; 2; 3	1; 2	1; 2
1040	845	195	585 ... 4095	3; 4; 5 ... 21	1; 2; 3	1; 2	1; 2
1040	845	260	780 ... 4160	3; 4; 5 ... 16	1; 2; 3	1; 2	1; 2

b = Track width
 l_{WT} = Workpiece pallet length, note the interdependencies for p and l_{WT} !
 p = Roller spacing (pitch)
 l = Length graduated according to the roller dimensions ($l = p \times N$)

N = Number of rollers, multiplier for length ($l = p \times N$), pricing factor in the price list
 LG = Lateral guide material
 1: Steel
 2: Plastic
 3: Aluminum

BG = Bevel wheel material
 1: Plastic
 2: Sintered metal
 TR = Roller material
 1: Steel, galvanized
 2: Steel, nitrocarburized

Dimensions

Conveyor unit ST 5/XH-FR, ST 5/H-FR

ST 5/XH-FR

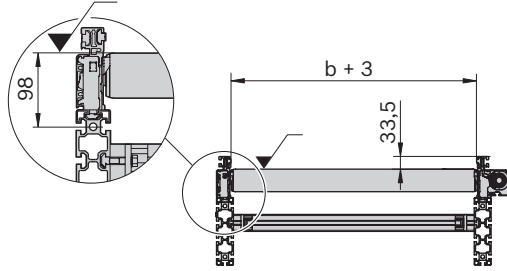
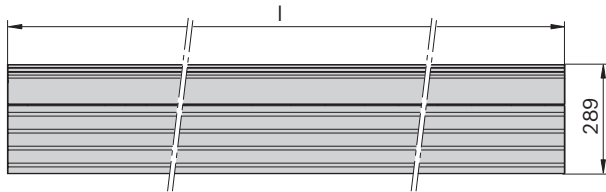

ST 5/ H-FR

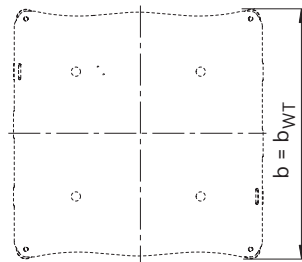
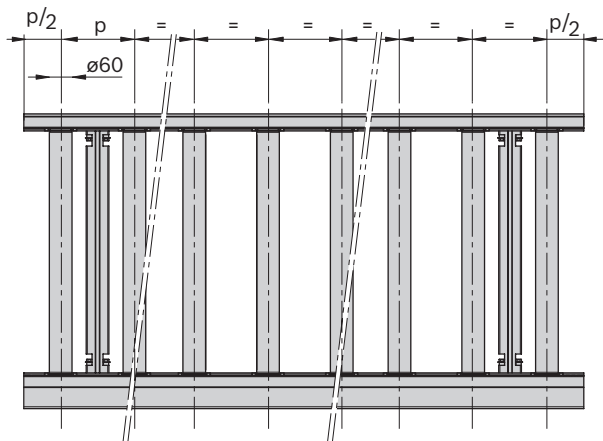
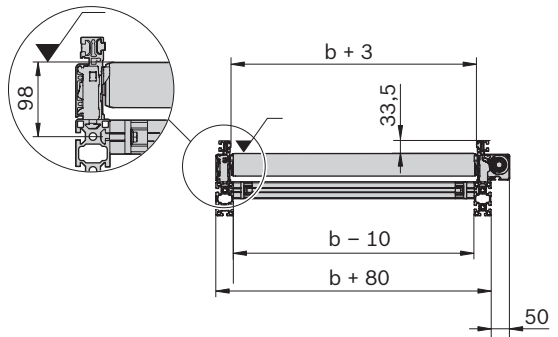
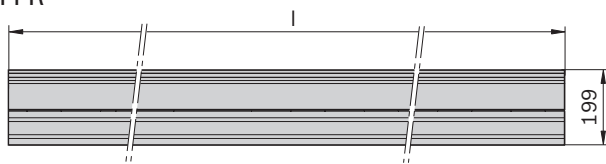

ST 5/XH-FR: 3 842 998 523
 ST 5/H-FR: 3 842 998 522

00132889

End plates for ST 5/XH-FR, ST 5/H-FR

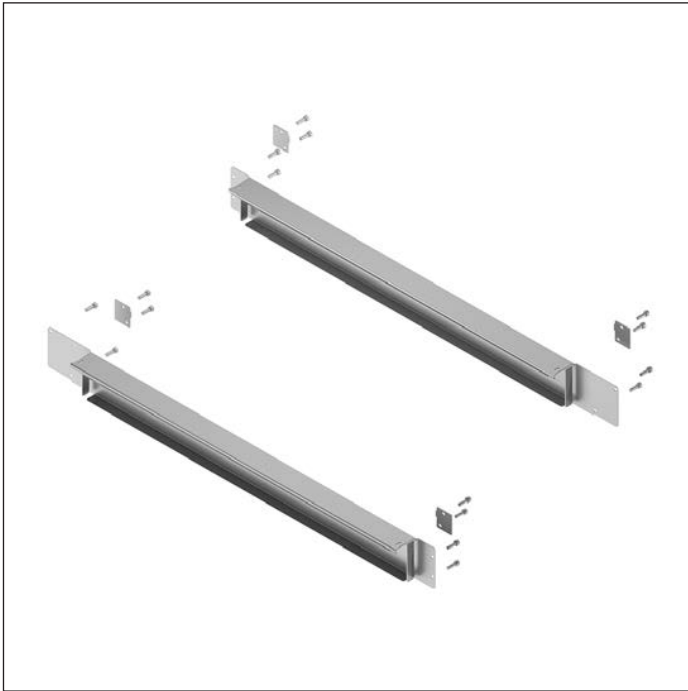

Use

- ▶ The protective covers and end plates are provided in working areas to increase safety. They can be ordered separately for conveyor units; for curves, diverters, and junctions they are optionally included in the scope of delivery (SC = 2)
- ▶ The protective covers and end plates are clipped between the rollers using spring elements

Notice: Do not walk on the protective covers or end plates.

Version

- ▶ Protective covers for various widths and roller spacings.
- ▶ Special covers for conveyor section center, transitions, and ends.

Material

- ▶ Steel, galvanized

Ordering information

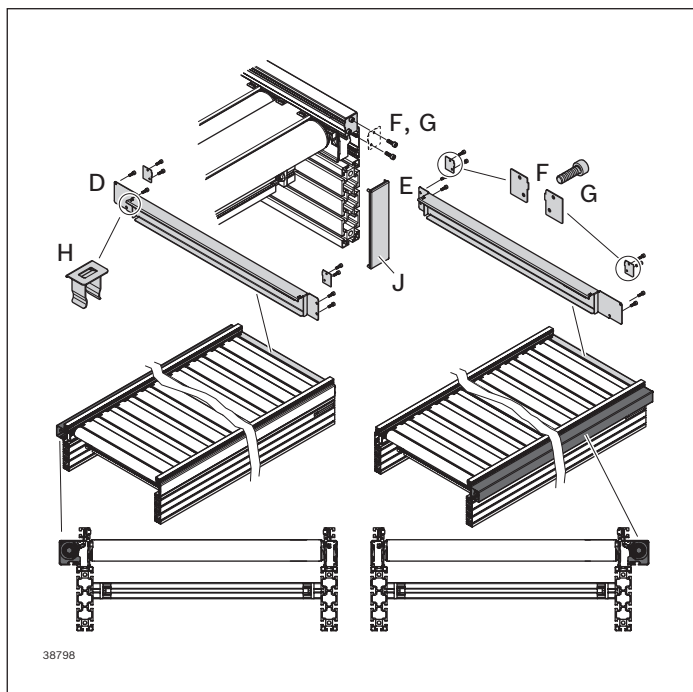

End plates

- ▶ End plate, left drive side (**D**)
- ▶ End plate, right drive side (**E**)

	b (mm)	p (mm)	Material number
D	455	130	3 842 545 659
	455	195	3 842 545 660
	650	130	3 842 545 661
	650	195	3 842 545 662
	650	260	3 842 545 663
	845	130	3 842 545 664
	845	195	3 842 545 665
	845	260	3 842 545 666
	845	325	3 842 545 667
	1040	130	3 842 545 468
	1040	195	3 842 545 469
	1040	260	3 842 545 668
E	455	130	3 842 545 669
	455	195	3 842 545 670
	650	130	3 842 545 671
	650	195	3 842 545 672
	650	260	3 842 545 673
	845	130	3 842 545 674
	845	195	3 842 545 675
	845	260	3 842 545 676
	845	325	3 842 545 677
	1040	130	3 842 545 466
	1040	195	3 842 545 467
	1040	260	3 842 545 678

b = Track width
p = Roller spacing

Lateral guide cover

- ▶ Lateral guide protective cover (**F**), 2 required

		Material number
F	2	3 842 545 276

Thread forming screw

- ▶ Screw (**G**), 4 required for each end plate (**D/E**) and 2 for each lateral guide cover (**F**)

		Material number
G	100	3 842 563 978

Spring element

- ▶ Spring element (**H**), 2 required for each end plate

		Material number
H	50	3 842 545 214

Cover caps

- ▶ Cover cap for the open profile ends (**J**), 2 required for each section end

		Material number	
J	ST 5/XH (45x180)	20	3 842 503 845
	ST 5/H (45x90)	20	3 842 511 783

Protective covers for ST 5/XH-FR, ST 5/H-FR

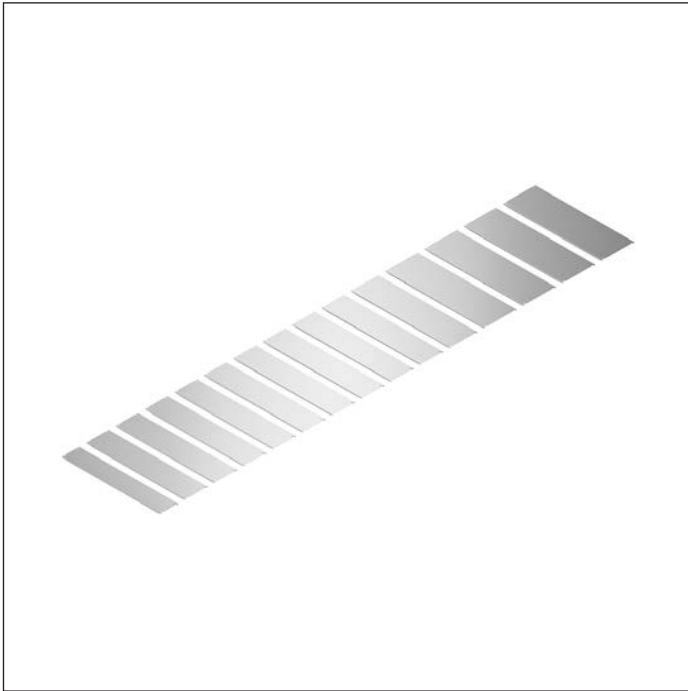

- ▶ Section center protective cover (**A**)
- ▶ Protective covers for transition between curve (diverter, junction) / conveyor unit (**B**)
- ▶ Protective covers for transition between conveyor unit/conveyor unit with different rollers (**C**)
- ▶ Spring element (**H**), 4 required for each protective cover, see page 4-16

The different dimensions of the protective covers can be found on page 4-16.

Ordering information

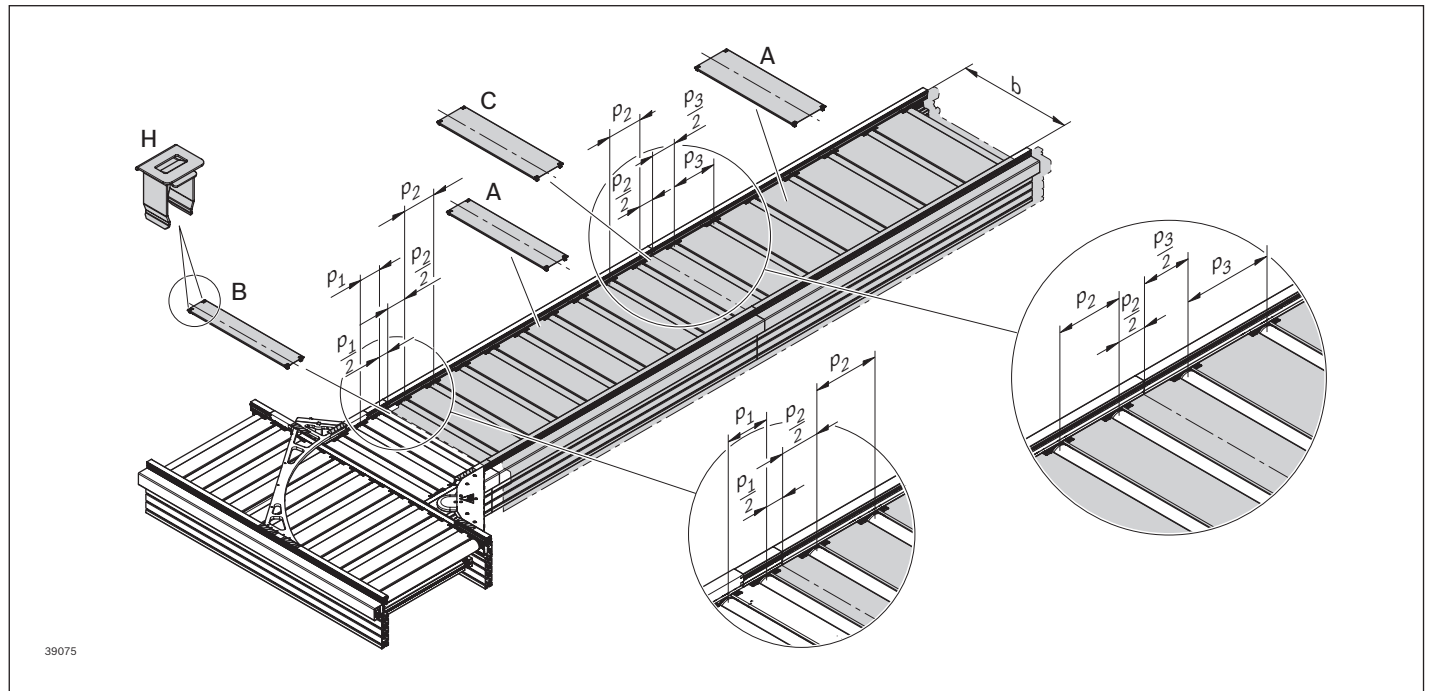

Protective covers for section center (A) and transitions (B, C)

	b (mm)	p (mm)	Material number
A	455	130	3 842 545 406
	455	195	3 842 545 610
	650	130	3 842 545 407
	650	195	3 842 545 408
	650	260	3 842 545 613
	845	130	3 842 545 409
	845	195	3 842 545 410
	845	260	3 842 545 411
	845	325	3 842 545 415
	1040	130	3 842 545 412
1040	195	3 842 545 413	
1040	260	3 842 545 414	

	b (mm)	p2/p3 (mm)	Material number
C	455	130/195	3 842 545 614
	650	130/195	3 842 545 620
	650	195/260	3 842 545 642
	845	130/195	3 842 545 626
	845	195/260	3 842 545 630
	845	260/325	3 842 545 643
	1040	130/195	3 842 545 639
	1040	195/260	3 842 545 637

	b (mm)	p1/p2 (mm)	Material number
B	455	130/130	3 842 545 406
	455	130/195	3 842 545 614
	650	130/130	3 842 545 407
	650	130/195	3 842 545 620
	650	130/260	3 842 545 408
	845	130/130	3 842 545 409
	845	130/195	3 842 545 626
	845	130/260	3 842 545 410
	845	130/325	3 842 545 630
	1040	130/130	3 842 545 412
1040	130/195	3 842 545 639	
1040	130/260	3 842 545 413	

b = Track width
 p = Roller spacing (pitch); p1/p2 and p2/p3
 = Transition between different roller spacing dimensions

Spring element

► Spring element (H), 2 required for each end plate

		Material number
H	50	3 842 545 214

Conveyor units ST 5/OC (Open Center)



Condition on delivery

- ▶ Ready-to-install

Use

- ▶ The conveyor unit is a ready-for-operation module used to transport workpiece pallets. The open center allows processes from below

Version

- ▶ Reversible operation possible
- ▶ Accumulation operation possible
- ▶ Support profile made of anodized aluminum
- ▶ Permissible section load: 380 kg/m
- ▶ Lateral guide profile made of steel, plastic, or aluminum in an anodized aluminum support
- ▶ Driven via king shaft with bevel wheels made of plastic or sintered metal
- ▶ Suitable for cleanroom of ISO class 7
- ▶ Suitable for dry room <1% RH

Ordering information

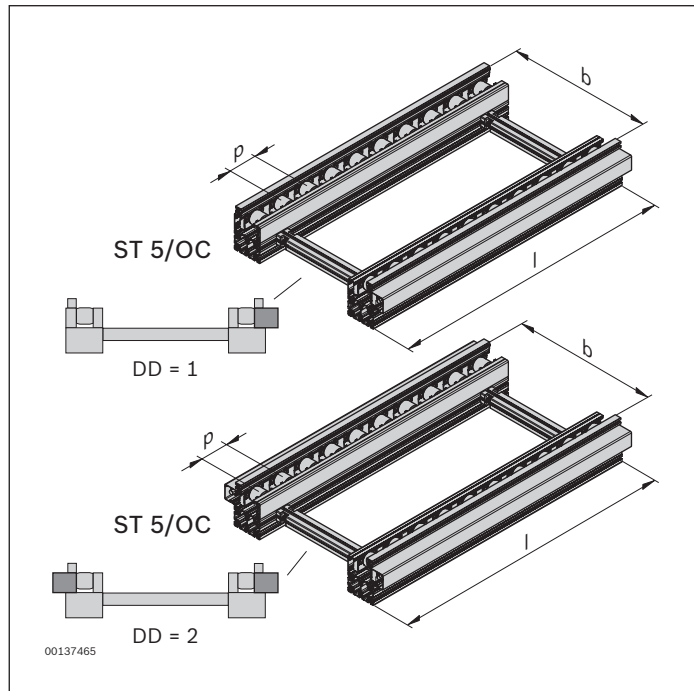

Conveyor units ST 5/OC (Open Center)

Product description	Material number
ST 5/OC	3 842 998 574
	b = ... mm
	l_{WT} = ... mm
	p = ... mm
	l = ... mm
	LG = ...
	BG = ...
	TR = ...
	DD = ...

Conveyor units ST 5/OC (Open Center)

b (mm)	l_{WT} (mm)	p (mm)	l (mm)	N	LG	BG	TR	DD
455	455; 650	130	390 ... 4160	3; 4; 5 ... 32	1; 2; 3	1; 2	1; 2	1; 2
455	650	195	585 ... 4095	3; 4; 5 ... 21	1; 2; 3	1; 2	1; 2	1; 2
650	650; 845	130	390 ... 4160	3; 4; 5 ... 32	1; 2; 3	1; 2	1; 2	1; 2
650	650; 845	195	585 ... 4095	3; 4; 5 ... 21	1; 2; 3	1; 2	1; 2	1; 2
650	845	260	780 ... 4160	3; 4; 5 ... 16	1; 2; 3	1; 2	1; 2	1; 2
845	845; 1040	130	390 ... 4160	3; 4; 5 ... 32	1; 2; 3	1; 2	1; 2	1; 2
845	845; 1040	195	585 ... 4095	3; 4; 5 ... 21	1; 2; 3	1; 2	1; 2	1; 2
845	845; 1040	260	780 ... 4160	3; 4; 5 ... 16	1; 2; 3	1; 2	1; 2	1; 2
845	1040	325	975 ... 3900	3; 4; 5 ... 12	1; 2; 3	1; 2	1; 2	1; 2
1040	845	130	390 ... 4160	3; 4; 5 ... 32	1; 2; 3	1; 2	1; 2	1; 2
1040	845	195	585 ... 4095	3; 4; 5 ... 21	1; 2; 3	1; 2	1; 2	1; 2
1040	845	260	780 ... 4160	3; 4; 5 ... 16	1; 2; 3	1; 2	1; 2	1; 2

b = Track width

l_{WT} = Workpiece pallet length, note the interdependencies for p and l_{WT} !

p = Roller spacing (pitch)

l = Length graduated according to the roller dimensions ($l = p \times N$)

N = Number of rollers, multiplier for length ($l = p \times N$), pricing factor in the price list

LG = Lateral guide material
 1: Steel
 2: Plastic
 3: Aluminum

BG = Bevel wheel material

1: Plastic
 2: Sintered metal

TR = Roller material
 1: Steel, galvanized
 2: Steel, nitrocarburized

DD = Drive
 1: on one side
 2: on two sides

Dimensions

Conveyor unit ST 5/OC (Open Center)

ST 5/OC
 DD = 1

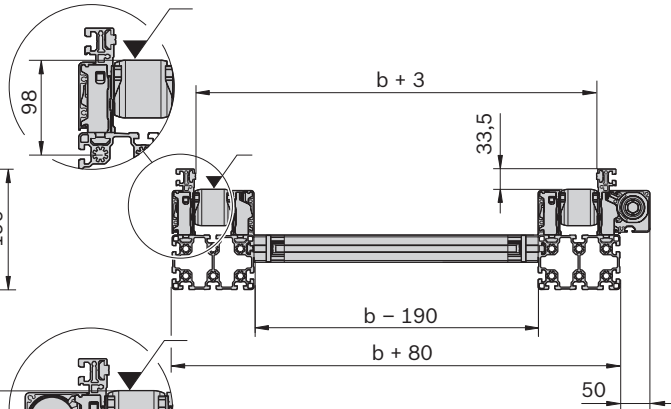
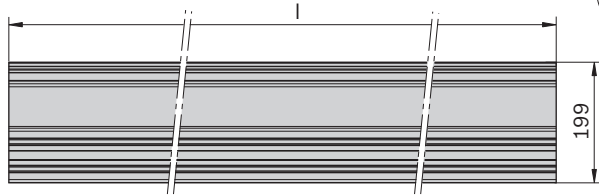

ST 5/OC
 DD = 2

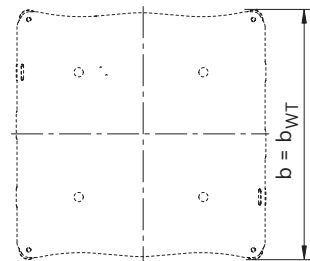
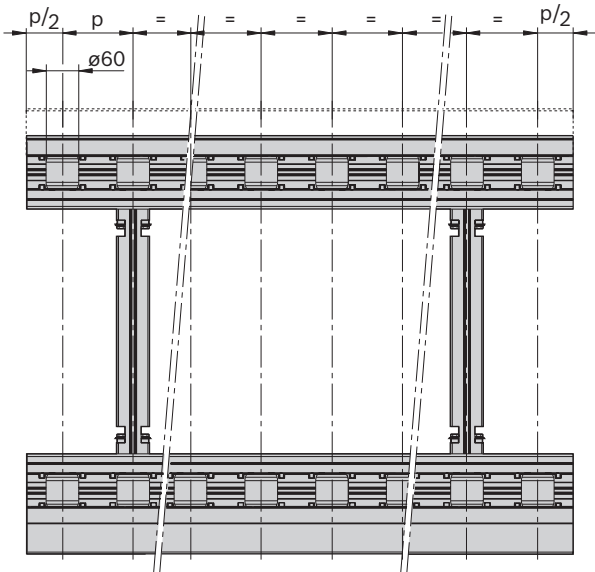
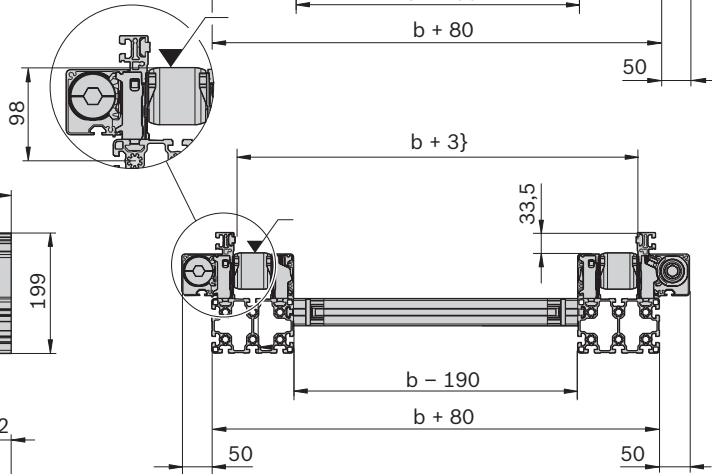
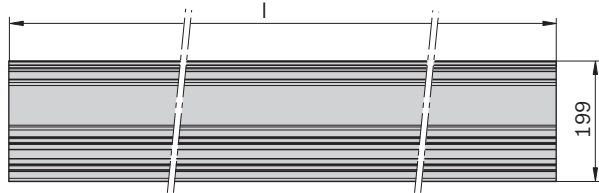

ST 5/OC: 3 842 998 574

00137466

End plates for ST 5/OC

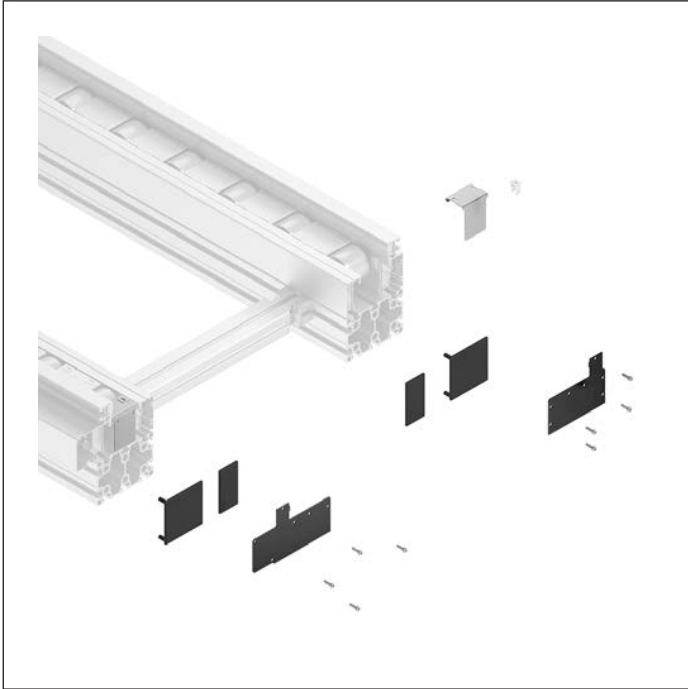

Use

- ▶ The protective covers and end plates are provided in working areas to increase safety

Notice: Do not walk on the protective covers or end plates.

Version

- ▶ Protective covers for various roller spacings
- ▶ Special covers for conveyor section center, transitions, and ends

Material

- ▶ Steel, galvanized

Ordering information

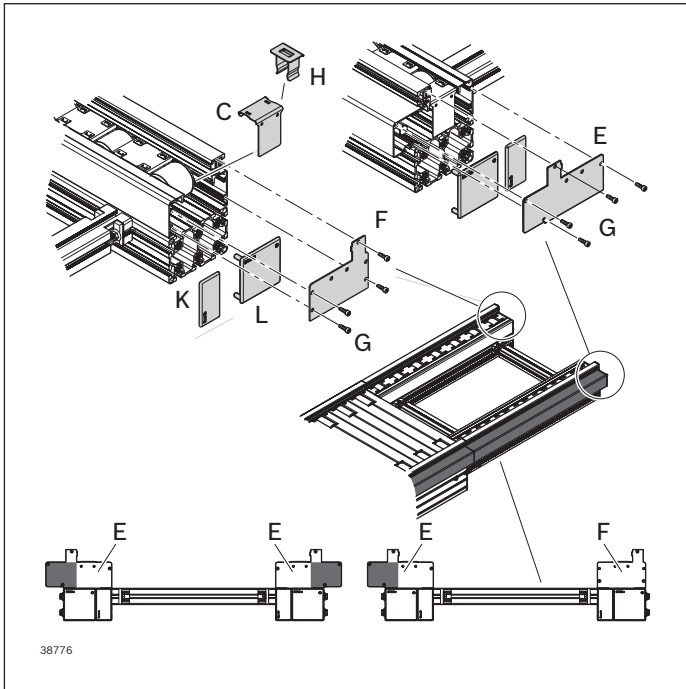

End plates (C)

- ▶ End plate for drive side (E), left/right
- ▶ End plate for passive side (F), left/right

	p (mm)		Material number
C	130	2	3 842 545 573
	195	2	3 842 545 574
	260	2	3 842 545 575
	325	2	3 842 545 576
E			3 842 559 589
F			3 842 559 590

p = Roller spacing

Thread forming screws for end plates

- ▶ Screw (G), 4 required for each end plate (E/F)

		Material number
G	100	3 842 563 978

Spring element (H)

- ▶ Spring element, 2 required for each end plate

		Material number
H	50	3 842 545 214

End caps (K, L)

- ▶ Cover cap for the open profile ends, 2 required for each section end

		Material number
K	20	3 842 511 783
L	20	3 842 516 214

Protective covers for ST 5/OC



- ▶ Section center protective cover (**A**)
- ▶ Protective covers for transition between conveyor unit/conveyor unit with the same or different rollers (**B**)
- ▶ Spring element (**H**), 4 required for each protective cover

Ordering information

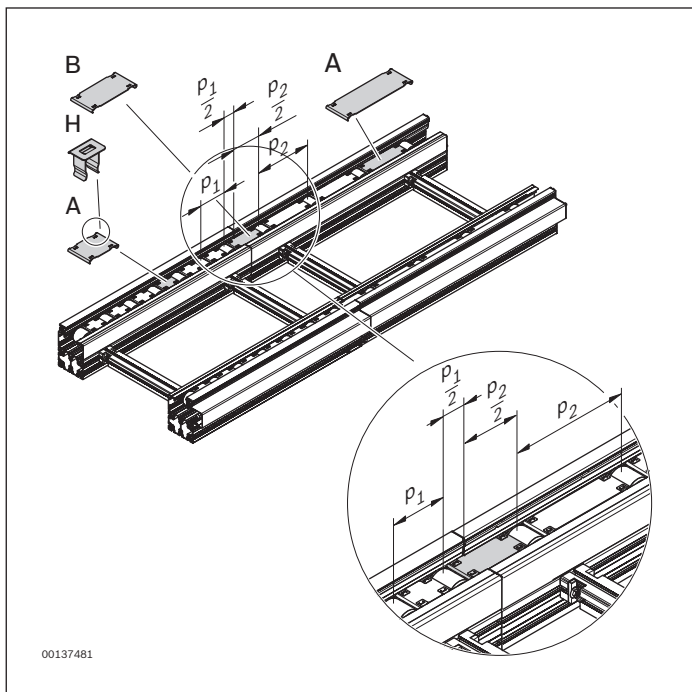

Protective covers for section center (A) and transitions (B)

	p (mm)	Material number
A	130	3 842 545 541
	195	3 842 545 543
	260	3 842 545 545
	325	3 842 545 547

p = Roller spacing (pitch); p1/p2 = Transition between different roller spacing dimensions

	p1/p2 (mm)	Material number
B	130/130	3 842 545 541
	130/195	3 842 545 542
	195/195	3 842 545 543
	195/260	3 842 545 544
	260/260	3 842 545 545
	260/325	3 842 545 546
	325/325	3 842 545 547

p = Roller spacing (pitch); p1/p2 = Transition between different roller spacing dimensions

Spring element

		Material number
H	50	3 842 545 214

Cover for transition OC/XH, OC/H

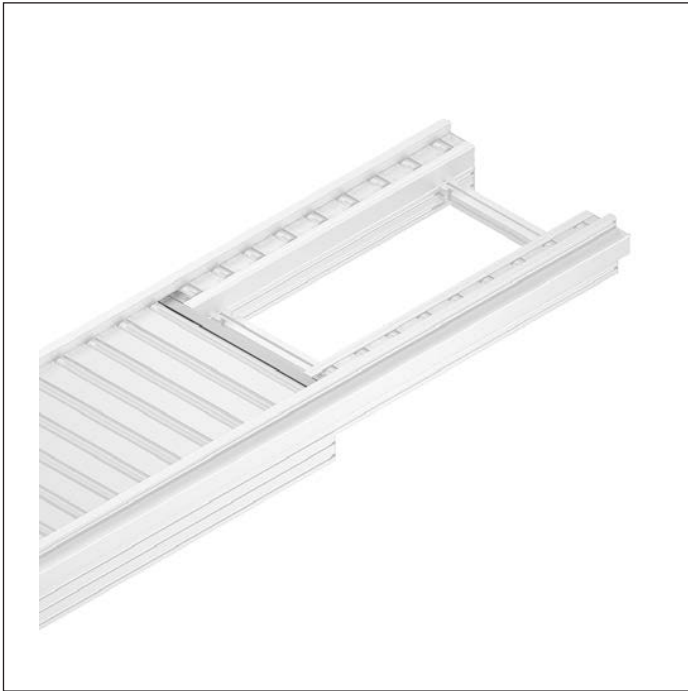

- ▶ Protective cover (**C**)
- ▶ Cover for split rollers (**D1**)
- ▶ Cover for full rollers (**D2**)
- ▶ Spring element (**H**)
- ▶ End plate for open profile ends (**I**)
- ▶ Screw (**J**), 2 required for each lateral guide cover
- ▶ Screw (**K**), 1 required for each end plate
- ▶ Cover cap for the open profile ends (**L**)

The different dimensions of the protective covers can be found on page 4-24.

Ordering information

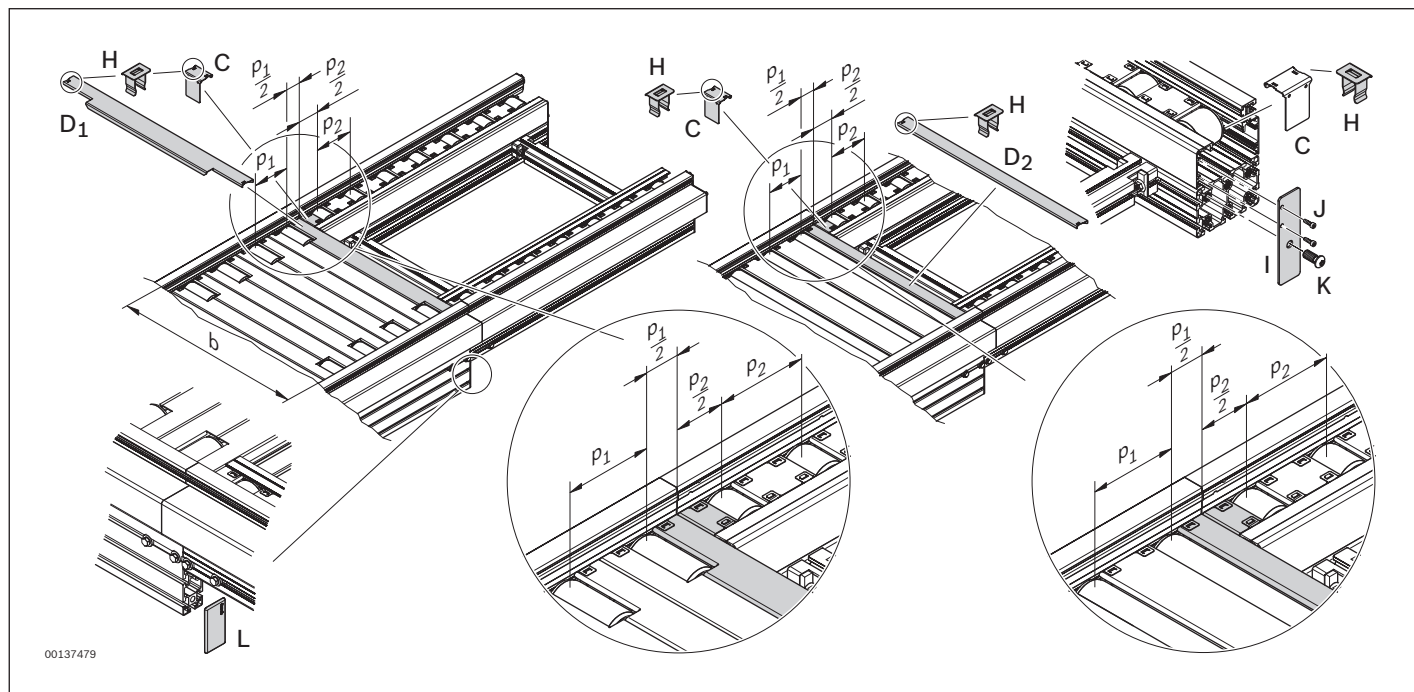

Cover

	b (mm)	p1 (mm)	Material number
D1	455	130	3 842 545 150
	455	195	3 842 545 151
	650	130	3 842 545 152
	650	195	3 842 545 153
	650	260	3 842 545 739
	845	130	3 842 545 154
	845	195	3 842 545 155
	845	260	3 842 545 740
	845	325	3 842 545 741
	1040	130	3 842 545 156
	1040	195	3 842 545 157
	1040	260	3 842 545 742
1040	325	3 842 545 745	

b = Track width
p = Roller spacing (pitch); p1/p2 = Transition between different roller spacing dimensions

Cover

		p2 (mm)	Material number
C	2	130	3 842 545 573
		195	3 842 545 574
		260	3 842 545 575
		325	3 842 545 576
I	1		3 842 549 670

b = Track width
P = Roller spacing (pitch); p1/p2 = Transition between different roller spacing dimensions

	b (mm)	p1 (mm)	Material number
D2	455	130	3 842 545 158
	455	195	3 842 545 248
	650	130	3 842 545 321
	650	195	3 842 545 548
	650	260	3 842 545 577
	845	130	3 842 545 549
	845	195	3 842 545 550
	845	260	3 842 545 578
	845	325	3 842 545 579
	1040	130	3 842 545 551
	1040	195	3 842 545 599
	1040	260	3 842 545 600
1040	325	3 842 545 737	

b = Track width
p = Roller spacing (pitch); p1/p2 = Transition between different roller spacing dimensions

Spring element

		Material number
H	50	3 842 545 214

Screw

		Material number
J	100	3 842 563 978
K	100	3 842 530 236

End cap

		Material number
L	20	3 842 511 855

Connection kits

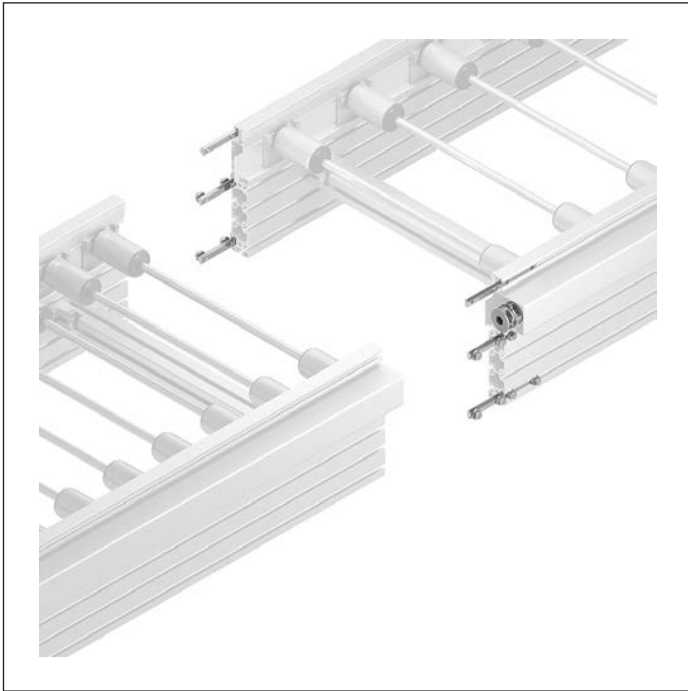

Use

The coupling is used to connect the king shafts. A cross plate in the coupling compensates for alignment errors and concentricity tolerances.

- ▶ To connect two TS 5 modules, you will need:
 - 4 profile connectors for section profiles (**A**)
 - 2 profile connectors for lateral guide (**B**)
 - 2 intermediate plates (**C**)
 - 1 coupling (**D**)

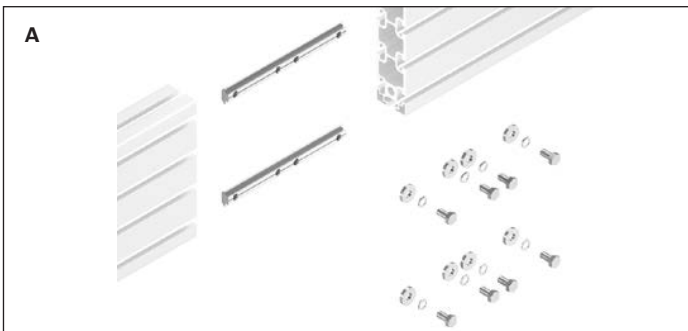

Profile connectors for section profiles/lateral guides

- ▶ The profile ends are connected to each other using profile connectors.

Material

- ▶ Steel, galvanized

Scope of delivery

- ▶ Profile connector, screws

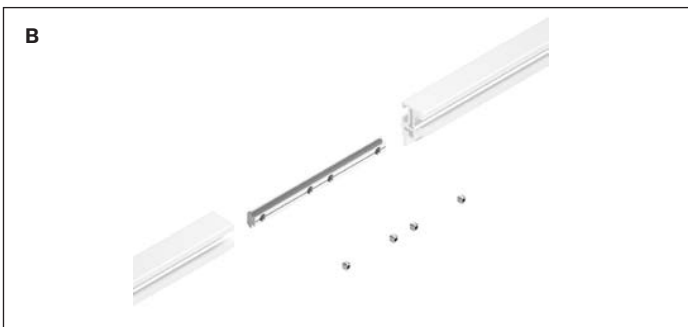

Profile connector for section profile

	Material number
A	3 842 528 746

Profile connector for lateral guide

		Material number
B	10	3 842 545 699

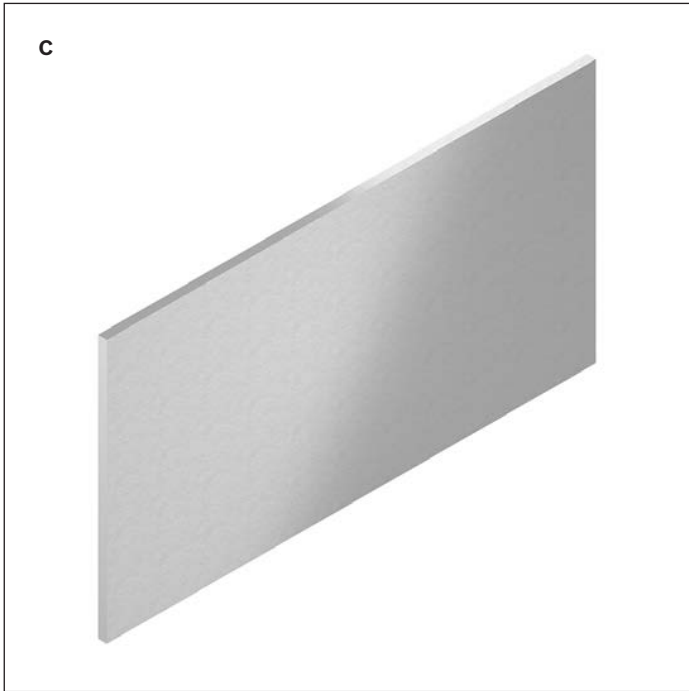

Intermediate plates for module transitions

- ▶ The modules (conveyor sections, drives, curves, diverters) are separated using intermediate plates with the respective roller dimension p.

Material

- ▶ Steel, galvanized

Intermediate plates for module transitions

		p1/p2 (mm)	Material number
C	10	130/130	3 842 545 215
	10	130/195	3 842 545 354
	10	130/260	3 842 545 216
	10	130/325	3 842 545 355
	10	195/195	3 842 545 216
	10	195/260	3 842 545 355
	10	260/260	3 842 545 217
	10	260/325	3 842 545 648
	10	325/325	3 842 545 218

P = Roller spacing (pitch); p1/p2 = Transition between different roller spacing dimensions

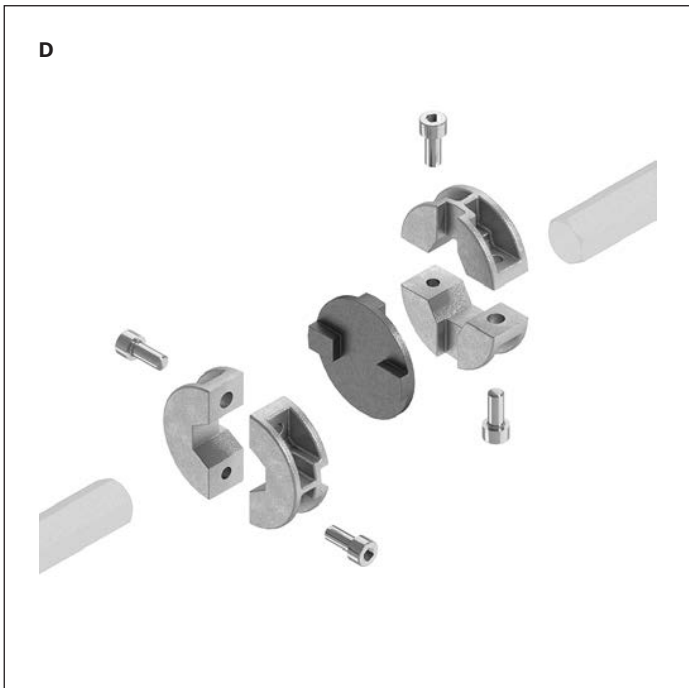

Coupling

- ▶ For connecting the king shaft. Compensates for alignment errors and concentricity tolerances.

Notice: The coupling disk must be greased by the customer.

Material

- ▶ Steel, galvanized
- ▶ Brass

Scope of delivery

- ▶ Coupling, screws

Coupling

		Material number
D	10	3 842 545 160

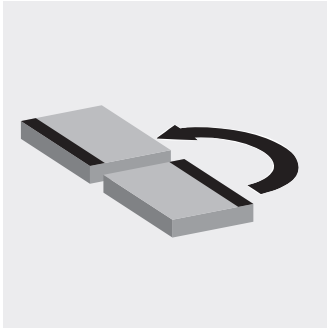

Curves/diverters/ rotary units

5

Design	5-2
Curves CU 5/XH, CU 5/H	5-4
Diverters DI 5/XH, DI 5/H	5-8
Junctions JU 5/XH, JU 5/H	5-13
Limits for the permissible gravity center position for junctions and diverters	5-17
Three-way diverter DI 5/XH-3W, DI 5/H-3W	5-18
Limits for the permissible gravity center position for the three-way diverter	5-22
Rotary unit DE 5	5-23
Rotary unit DE 5/FR	5-27
Rotary unit DE 5/OC	5-31

Design



Curves, diverters, and junctions are available for branching transport of workpiece pallets.
The main and secondary sections of these modules are separately driven via king shafts.

Permissible loads

m_e (kg)	v_N (m/min)
max. 260	12
max. 300	9

m_e = total weight of workpiece pallet

Higher weights available on request.
Can be adapted to different conveyor speeds.

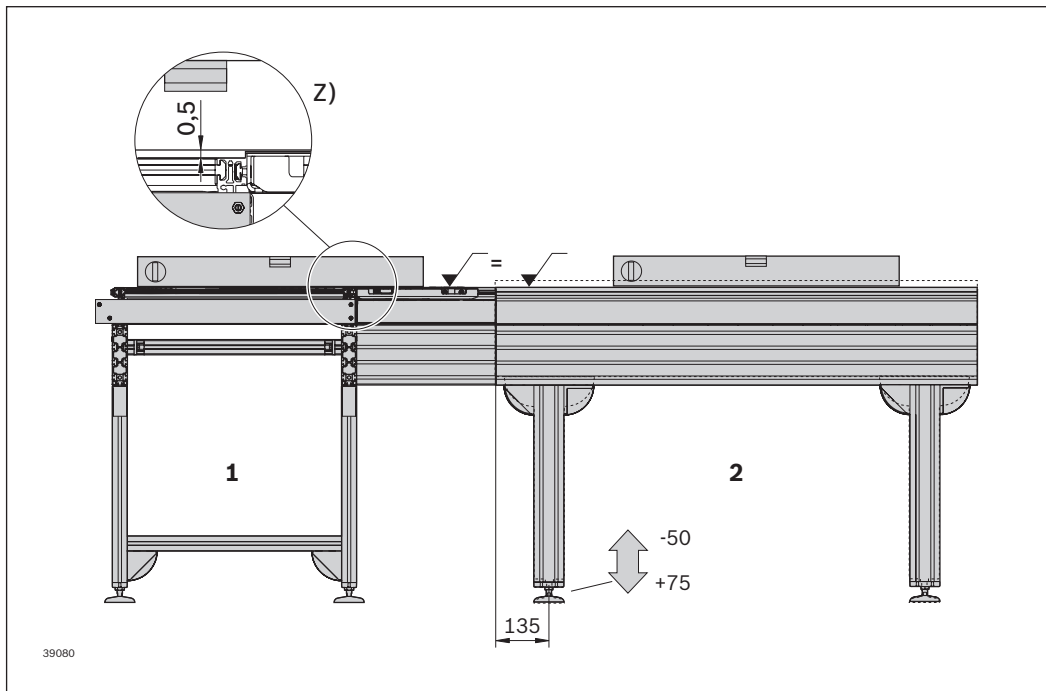

Notice: At curves, diverters and junctions, functional considerations mean that there is 0.5 mm (**Z**) difference between the transportation height of the main section (**1**) and secondary section (**2**). The secondary section is 0.5 mm higher. This is why curves, diverters, and junctions must always be arranged with an opposite orientation (see the graphic).

- 1 Main section
- 2 Secondary section

Arrangement of curves, diverters, and junctions

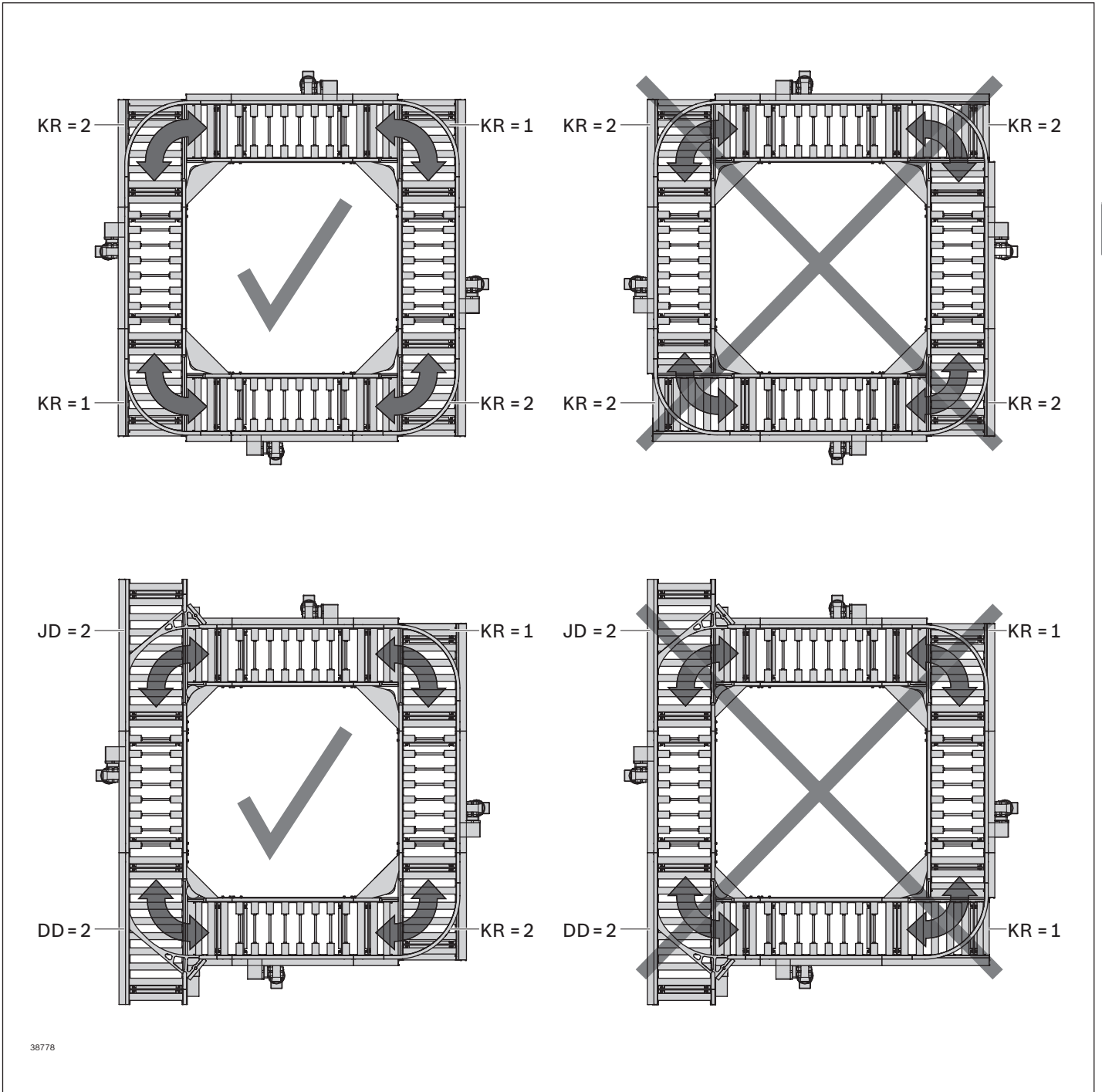

Curves CU 5/XH, CU 5/H

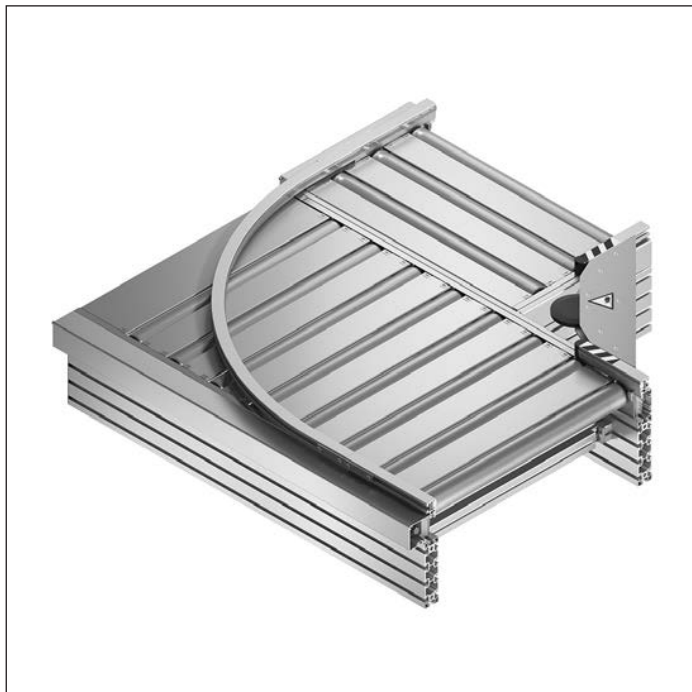

Condition on delivery

- ▶ Ready-to-install
- ▶ Protective covers mounted optionally
(protective covers cannot be ordered separately)

Use

The curve is a ready-for-operation module for branching transport of workpiece pallets. Curves can be driven either on the inside or on the outside.

Notice: The curve is not suitable for accumulation operation. Permissible loads, see page 5-6

Version

- ▶ Reversible operation possible
- ▶ Accumulation operation not permitted
- ▶ Support profile made of anodized aluminum
- ▶ Lateral guide profile made of steel, plastic, or aluminum in an anodized aluminum support
- ▶ Driven via king shaft with bevel gears made of sintered metal
- ▶ Drive possible with AB 5, see page 3-28
- ▶ Roller spacing $p = 130$
- ▶ Full rollers
- ▶ m_g up to 300 kg (where $v = 9$ m/min)

Ordering information

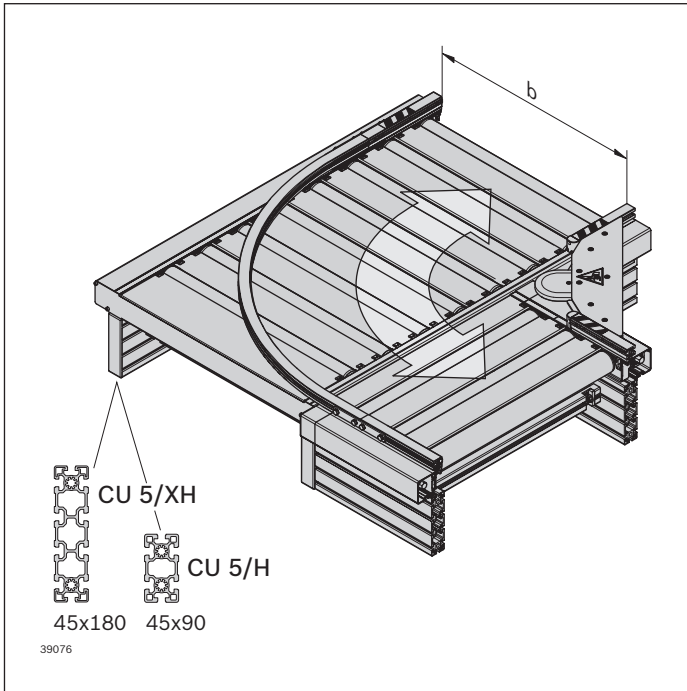

Curves CU 5/XH, CU 5/H

Product description	Material number
CU 5/XH	3 842 998 526
CU 5/H	3 842 998 525
	b = ... mm
	I_T = ... mm
	LG = ...
	KR = ...
	DSM = ...
	DST = ...
	TR = ...
	CT = ...

5

Curves CU 5/XH, CU 5/H

b (mm)	I_T (mm)	N	LG	KR	DSM	DST	TR	CT
455	455; 650	10	1; 2; 3	1; 2	1; 2	1; 2	1; 2	0; 1
650	650; 845	11	1; 2; 3	1; 2	1; 2	1; 2	1; 2	0; 1
845	845; 1040	13	1; 2; 3	1; 2	1; 2	1; 2	1; 2	0; 1

b = Track width
 I_T = Length in direction of transport
 N = Number of rollers, multiplier for length ($l = p \times N$), pricing factor in the price list

LG = Lateral guide material
 1: Steel
 2: Plastic
 3: Aluminum
 KR = Curve direction,
 1: left
 2: right
 DSM = King shaft installation on main section
 1: left
 2: right

DST = King shaft installation on secondary section
 1: left
 2: right
 TR = Roller material
 1: Steel, galvanized
 2: Steel, nitrocarburized
 CT = Protective covers
 0: without protective covers
 1: with protective covers

Description of further parameters, see page 0-3

Order examples, see page 5-6

Order examples

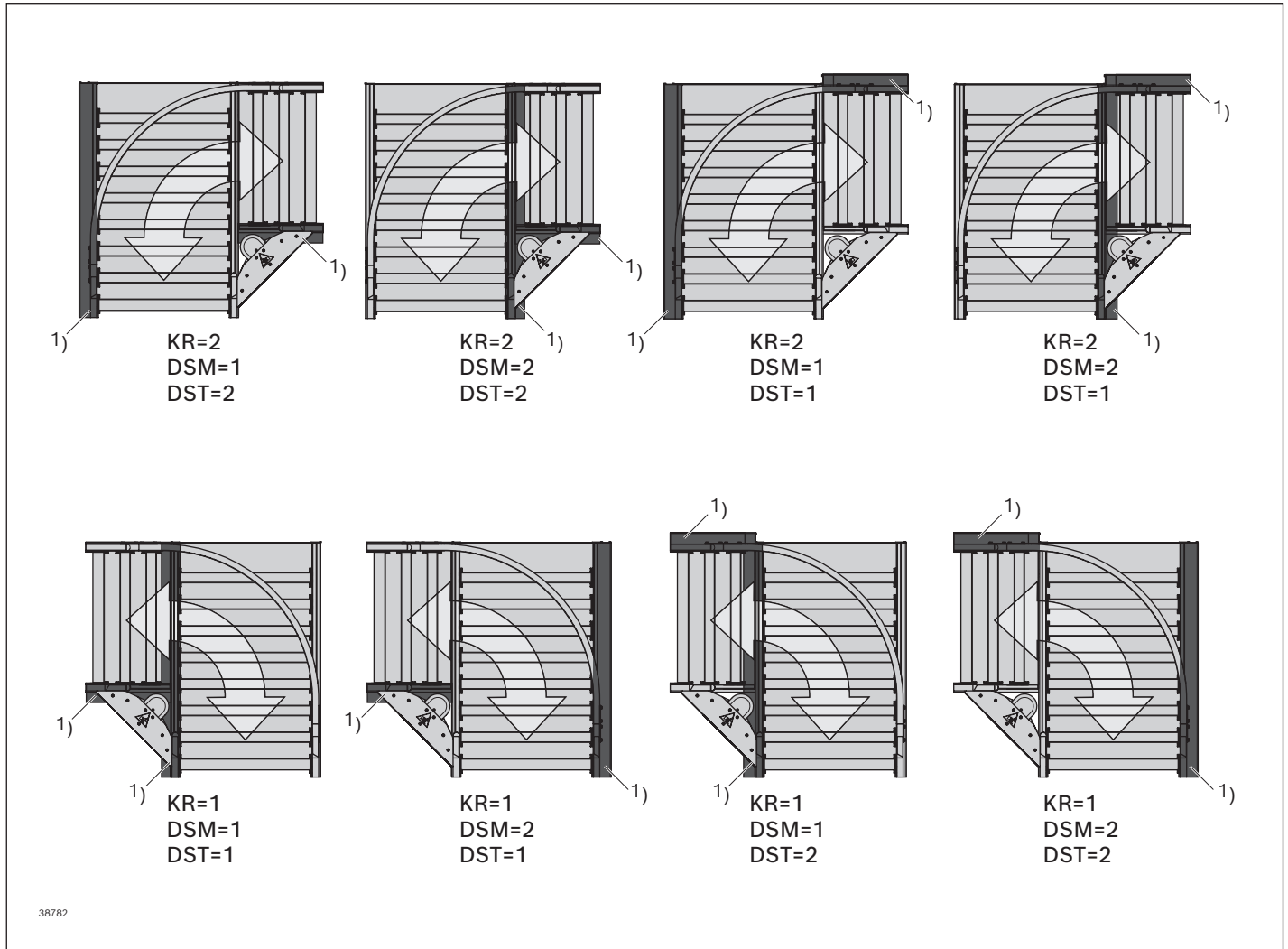

¹⁾ Drive side

Permissible loads

m_G (kg)	v_N (m/min)
max. 260	12
max. 300	9

m_G = total weight of workpiece pallet

Higher weights available on request.
Can be adapted to different conveyor speeds.

Dimensions

Curve CU 5/H, CU 5/XH

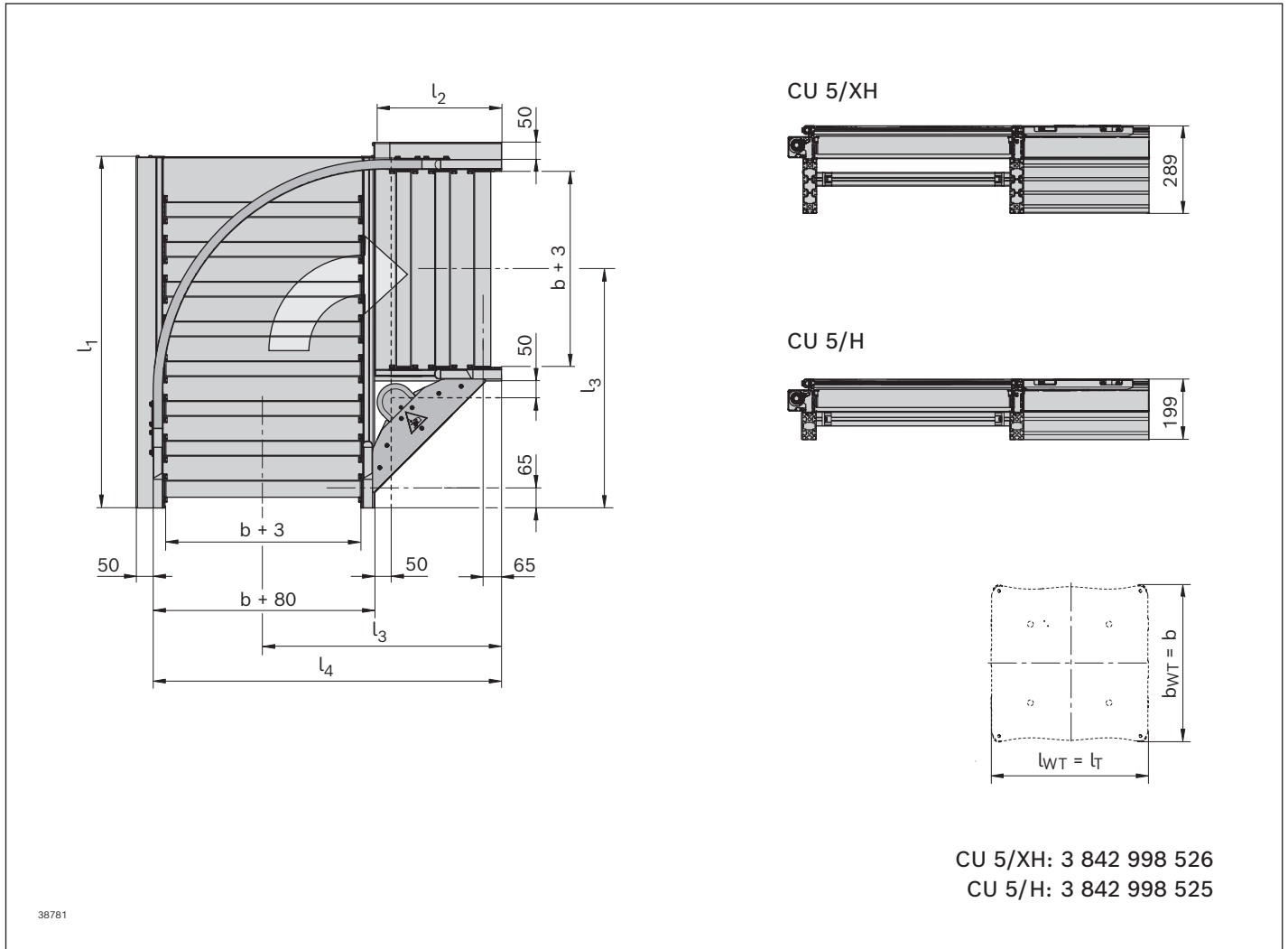

5

b (mm)	l_{WT} (mm)	N	l₁ (mm)	l₂ (mm)	l₃ (mm)	l₄ (mm)
455	455; 650	10	921.5	382.5	650	917.5
650	650; 845	11	1149	415	780	1145
845	845; 1040	13	1376.5	447	910	1372.5

b = Track width
 l_{WT} = Workpiece pallet length (in direction of transport)
 N = Number of rollers, multiplier for length (l = p × N), pricing factor in the price list

l₁ = Length of main section
 l₂ = Length of secondary section
 l₃ = Length of secondary section up to center of main section
 l₄ = Length of secondary section and width of main section

Diverters DI 5/XH, DI 5/H

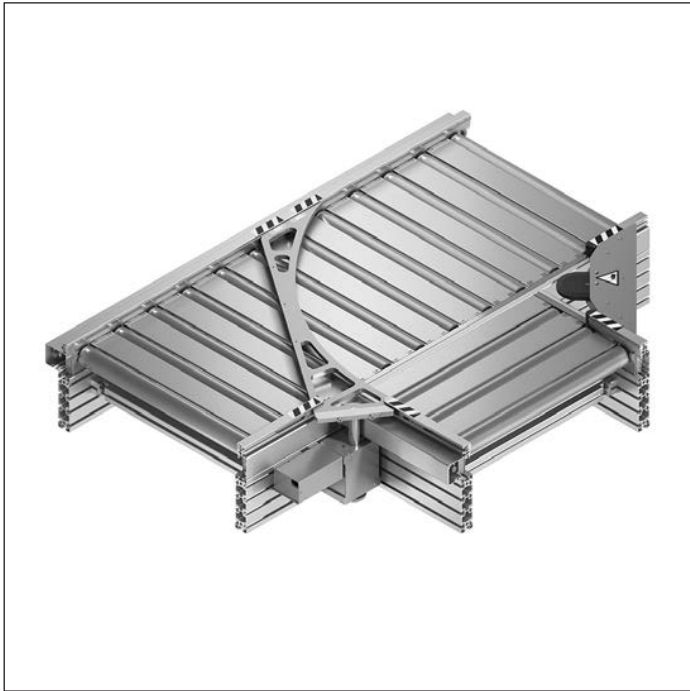

Condition on delivery

- ▶ Ready-to-install
- ▶ Protective covers mounted optionally
(protective covers cannot be ordered separately)

Use

The diverter is a ready-for-operation module for branching transport of workpiece pallets. The king shaft installation for the main or secondary section can be installed on either side. The diverter is controlled as an active element via a pneumatic cylinder ($p = 5 \dots 6 \text{ bar}$).

Notice: The diverter is not suitable for accumulation operation.
Permissible loads, see page 5-10

Version

- ▶ Reversible operation possible
- ▶ Accumulation operation not permitted
- ▶ Support profile made of anodized aluminum
- ▶ Lateral guide profile made of steel, plastic, or aluminum in an anodized aluminum support
- ▶ Driven via king shaft with bevel gears made of sintered metal
- ▶ Roller spacing $p = 130$
- ▶ Full rollers
- ▶ m_G up to 300 kg (where $v = 9 \text{ m/min}$)
- ▶ Push in air connection: 6 mm

Ordering information

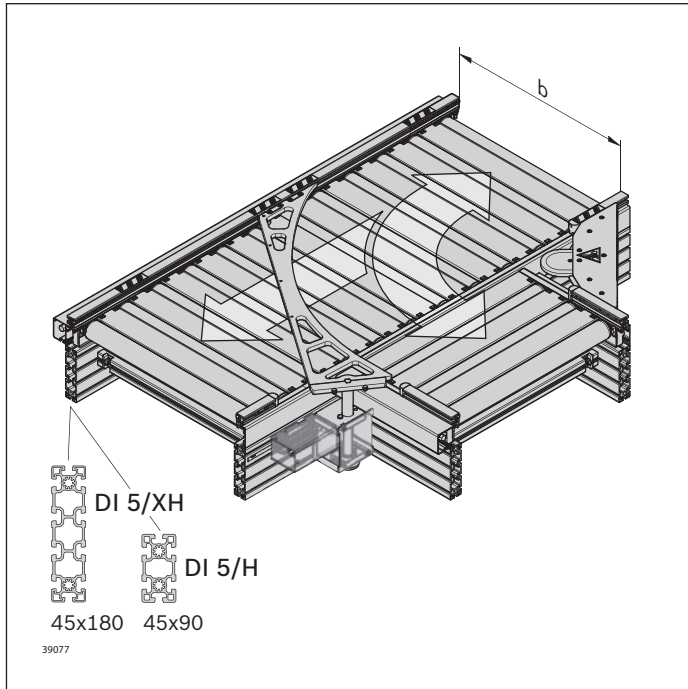

Diverters DI 5/XH, DI 5/H

Product description	Material number
DI 5/XH	3 842 998 529
DI 5/H	3 842 998 528
	b = ... mm
	l_{WT} = ... mm
	LG = ...
	DD = ...
	DSM = ...
	DST = ...
	TR = ...
	SC = ...

5

Diverters DI 5/XH, DI 5/H

b (mm)	l_{WT} (mm)	N	LG	DD	DSM	DST	TR	SC
455	455; 650	13	1; 2; 3	1; 2	1; 2	1; 2	1; 2	1; 2
650	650; 845	15	1; 2; 3	1; 2	1; 2	1; 2	1; 2	1; 2
845	845; 1040	17	1; 2; 3	1; 2	1; 2	1; 2	1; 2	1; 2

b = Track width
 l_{WT} = Workpiece pallet length
 (in direction of transport)
 N = Number of rollers, multiplier for
 length ($l = p \times N$), pricing factor in
 the price list

LG = Lateral guide material
 1: Steel
 2: Plastic
 3: Aluminum
 DD = Diverter direction
 1: left
 2: right
 DSM = King shaft installation on
 main section
 1: left
 2: right

DST = King shaft installation on
 secondary section
 1: left
 2: right
 TR = Roller material
 1: Steel, galvanized
 2: Steel, nitrocarburized
 SC = Protective covers
 1: without protective covers
 2: with protective covers

Description of further parameters,
 see page 0-3
 Order examples, see page 5-10

Order examples

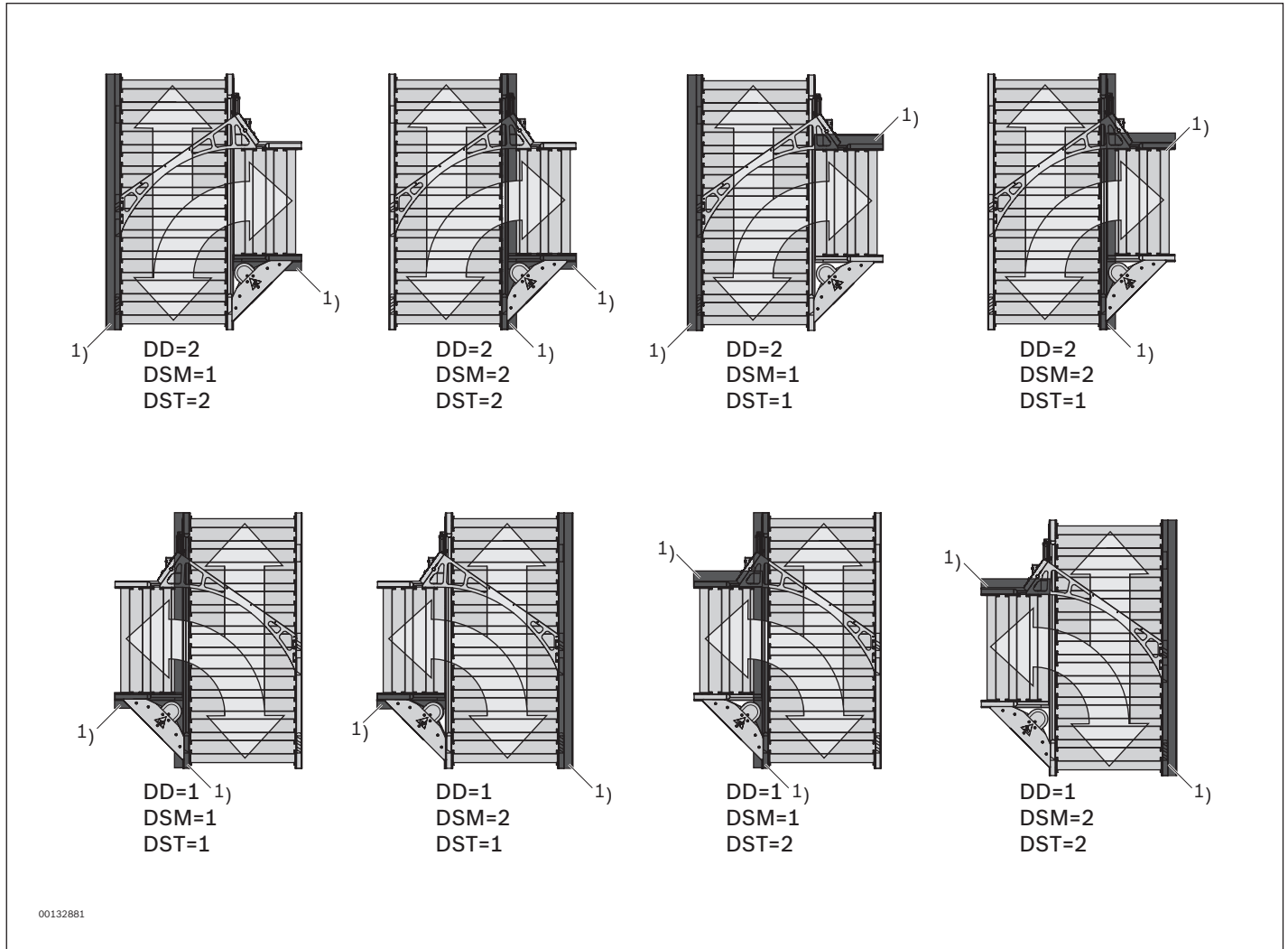

¹⁾ Drive side

Permissible loads

	m_G (kg)	v_N (m/min)
	max. 260	12
	max. 300	9

m_G = total weight of workpiece pallet

Higher weights available on request.
 Can be adapted to different conveyor speeds.
 Diverter arm position inquiry on request.

Dimensions

Diverter DI 5/H, DI 5/XH

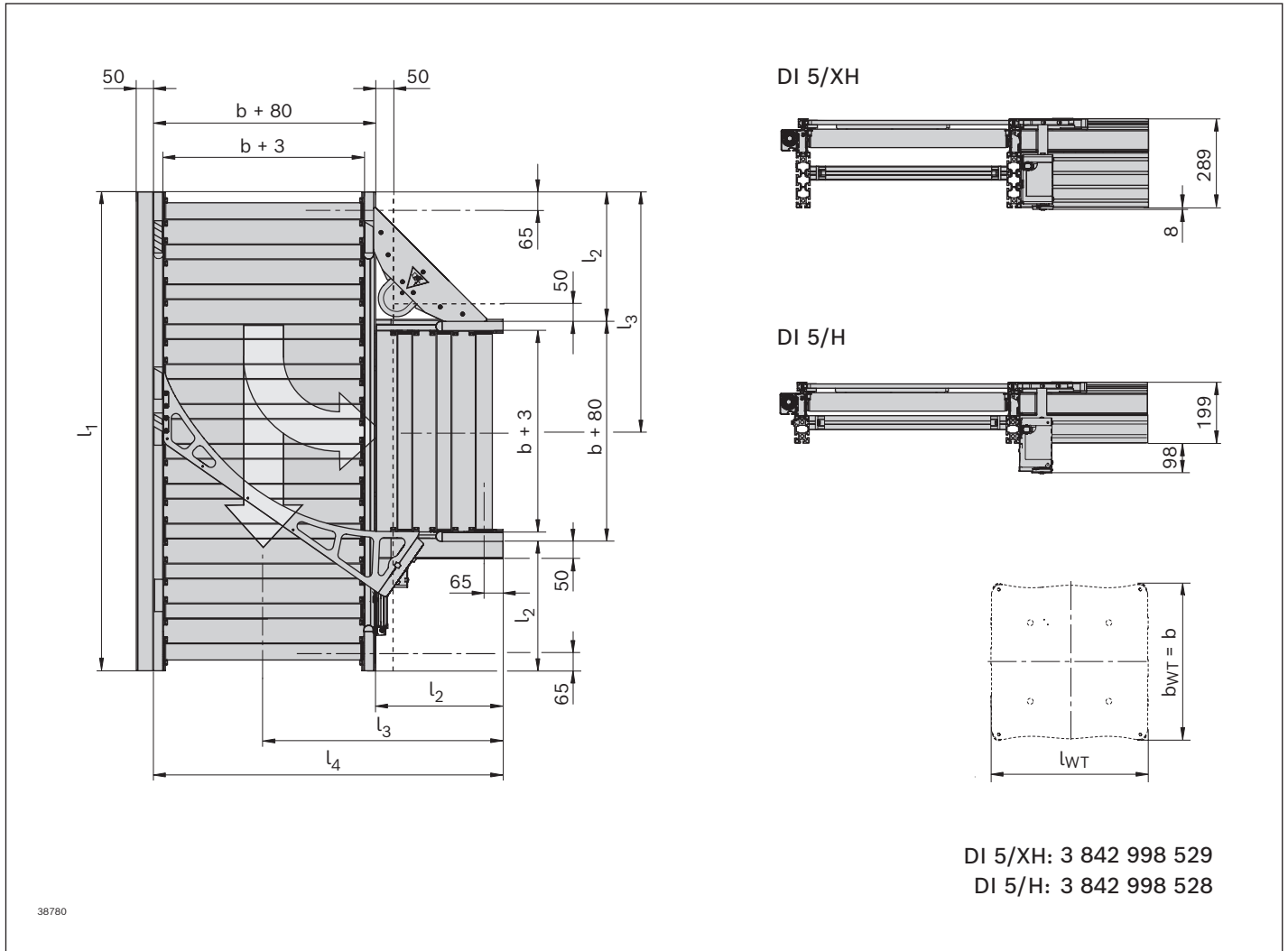

b (mm)	l_{WT} (mm)	N	l₁ (mm)	l₂ (mm)	l₃ (mm)	l₄ (mm)
455	455; 650	13	1300	382.5	650	917.5
650	650; 845	15	1560	415	780	1145
845	845; 1040	17	1820	447	910	1372.5

b = Track width
l_{WT} = Workpiece pallet length (in direction of transport)
N = Number of rollers, multiplier for length ($l = p \times N$), pricing factor in the price list

l₁ = Length of main section
l₂ = Length of secondary section
l₃ = Length of secondary section up to center of main section
l₄ = Length of secondary section and width of main section

Circuit diagram
diverter DI 5/H, DI 5/XH

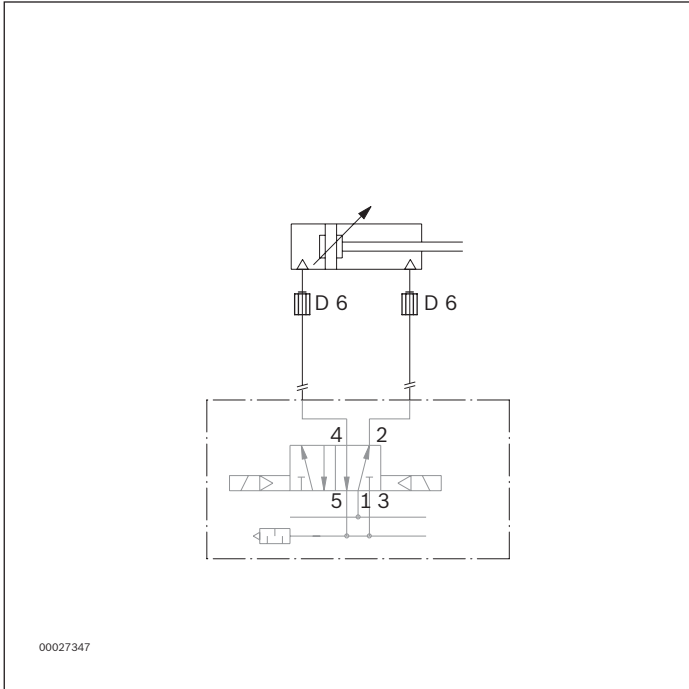

Junctions JU 5/XH, JU 5/H



Condition on delivery

- ▶ Ready-to-install
- ▶ Protective covers mounted optionally
(protective covers cannot be ordered separately)

Use

The junction is a module for branching transport of workpiece pallets. The king shaft installation for the main or secondary section can be installed on either side. The junction is a passive element without any control. The workpiece pallet moves the diverter arm into position.

Notice: The junction is not suitable for accumulation operation.

Permissible loads, see page 5-15

Version

- ▶ Reversible operation not permitted
- ▶ Accumulation operation not permitted
- ▶ Support profile made of anodized aluminum
- ▶ Lateral guide profile made of steel, plastic, or aluminum in an anodized aluminum support
- ▶ Driven via king shaft with bevel gears made of sintered metal
- ▶ Roller spacing $p = 130$
- ▶ Full rollers
- ▶ m_e up to 300 kg (where $v = 9$ m/min)

Ordering information

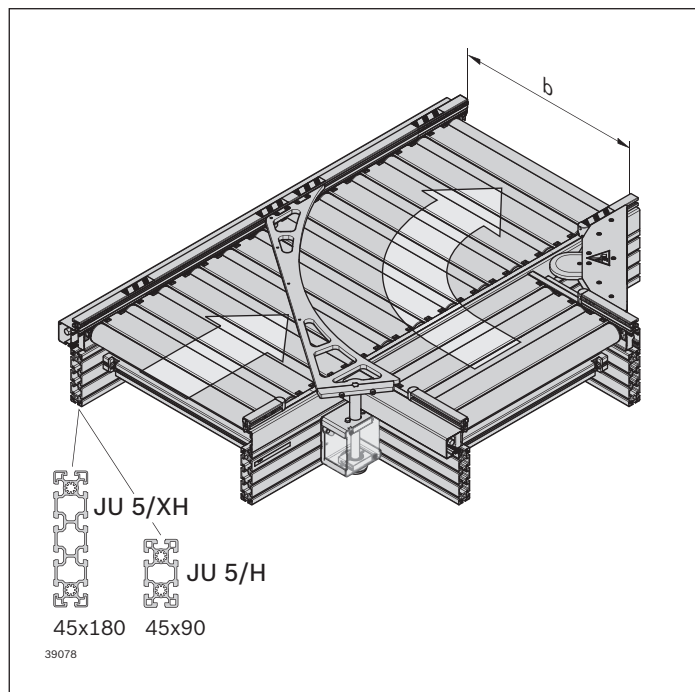

Junctions JU 5/XH, JU 5/H

Product description	Material number
JU 5/XH	3 842 998 531
JU 5/H	3 842 998 530
	b = ... mm
	l_{WT} = ... mm
	LG = ...
	JD = ...
	DSM = ...
	DST = ...
	TR = ...
	SC = ...

Junctions JU 5/XH, JU 5/H

b (mm)	l_{WT} (mm)	N	LG	JD	DSM	DST	TR	SC
455	455; 650	13	1; 2; 3	1; 2	1; 2	1; 2	1; 2	1; 2
650	650; 845	15	1; 2; 3	1; 2	1; 2	1; 2	1; 2	1; 2
845	845; 1040	17	1; 2; 3	1; 2	1; 2	1; 2	1; 2	1; 2

b = Track width
 l_{WT} = Workpiece pallet length
 (in direction of transport)
 N = Number of rollers, multiplier for
 length ($l = p \times N$), pricing factor
 in the price list

Description of further parameters,
 see page 0-3

Order examples, see page 5-15

LG = Lateral guide material
 1: Steel
 2: Plastic
 3: Aluminum

JD = Junction direction
 1: left
 2: right

DSM = King shaft installation on
 main section
 1: left
 2: right

DST = King shaft installation on
 secondary section
 1: left
 2: right

TR = Roller material
 1: Steel, galvanized
 2: Steel, nitrocarburized
 SC = Protective covers
 1: without protective covers
 2: with protective covers

Order examples

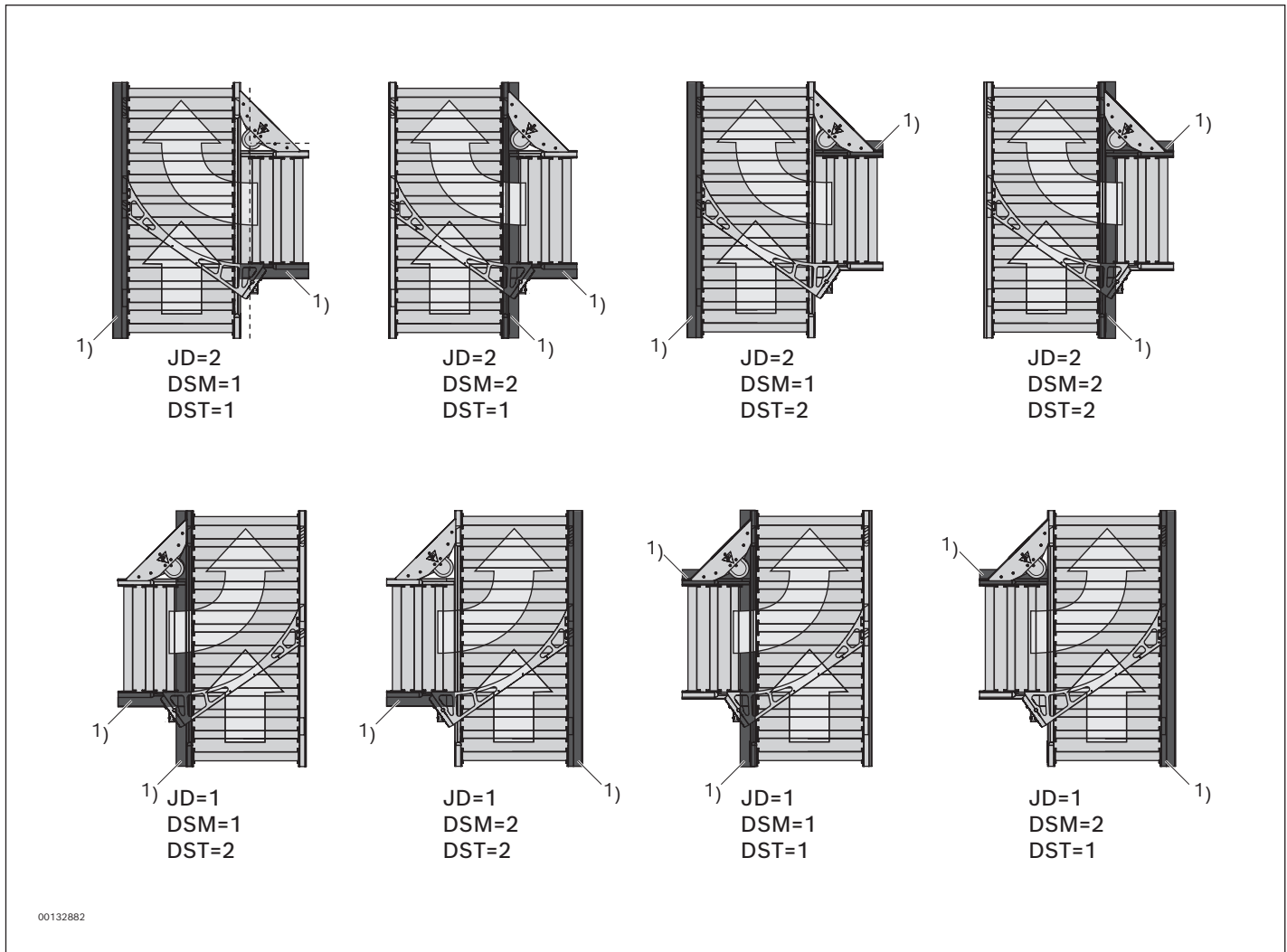

¹⁾ Drive side

Permissible loads

m_e (kg)	v_N (m/min)
max. 260	12
max. 300	9

m_e = total weight of workpiece pallet

Higher weights available on request.
 Can be adapted to different conveyor speeds.

Dimensions

junction JU 5/H, JU 5/XH

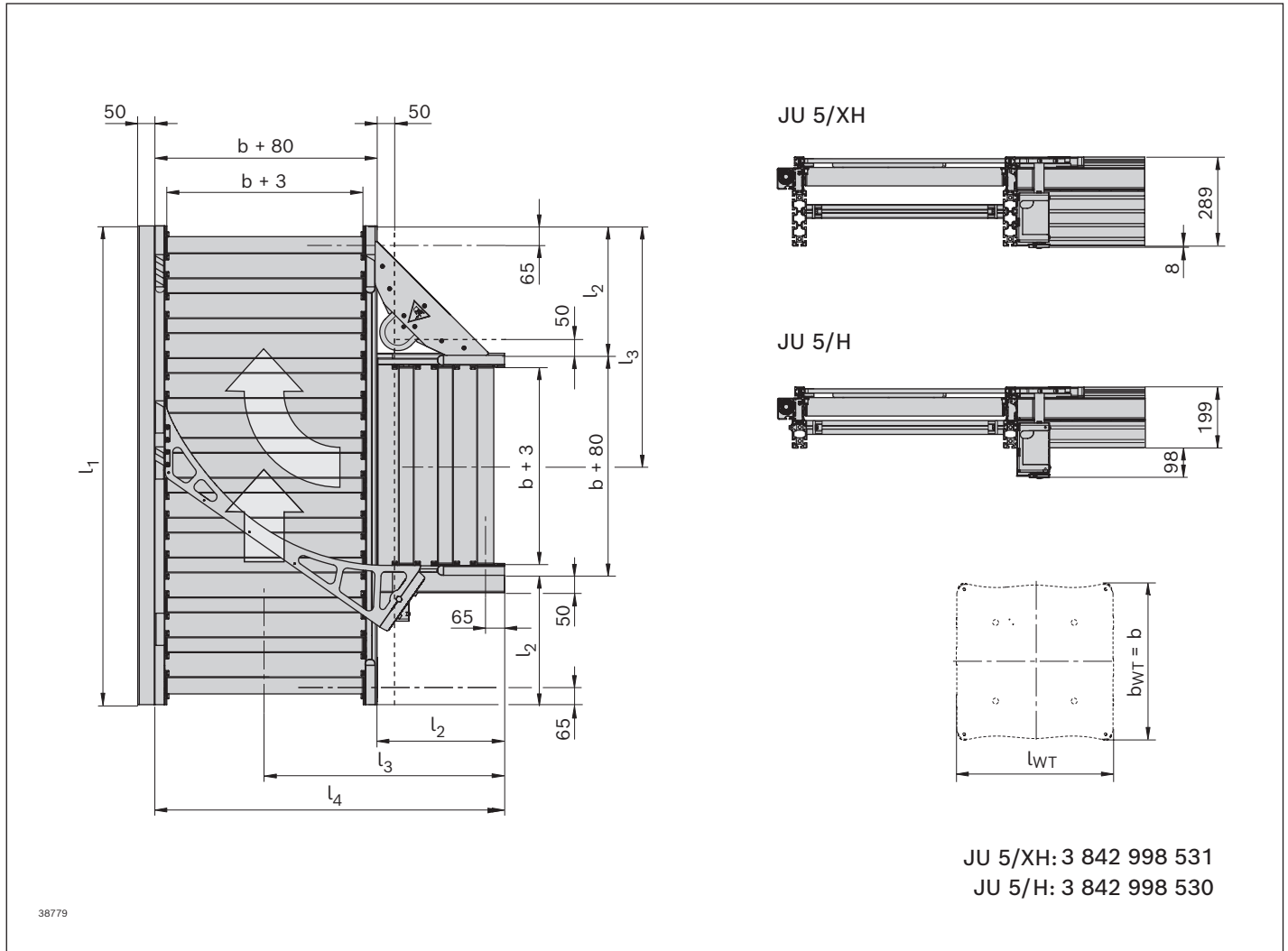

b (mm)	l_{WT} (mm)	N	l₁ (mm)	l₂ (mm)	l₃ (mm)	l₄ (mm)
455	455; 650	13	1300	382.5	650	917.5
650	650; 845	15	1560	415	780	1145
845	845; 1040	17	1820	447	910	1372.5

b = Track width
 l_{WT} = Workpiece pallet length (in direction of transport)
 N = Number of rollers, multiplier for length (l = p × N),
 pricing factor in the price list

l₁ = Length of main section
 l₂ = Length of secondary section
 l₃ = Length of secondary section up to center of main section
 l₄ = Length of secondary section and width of main section

Limits for the permissible gravity center position for junctions and diverters

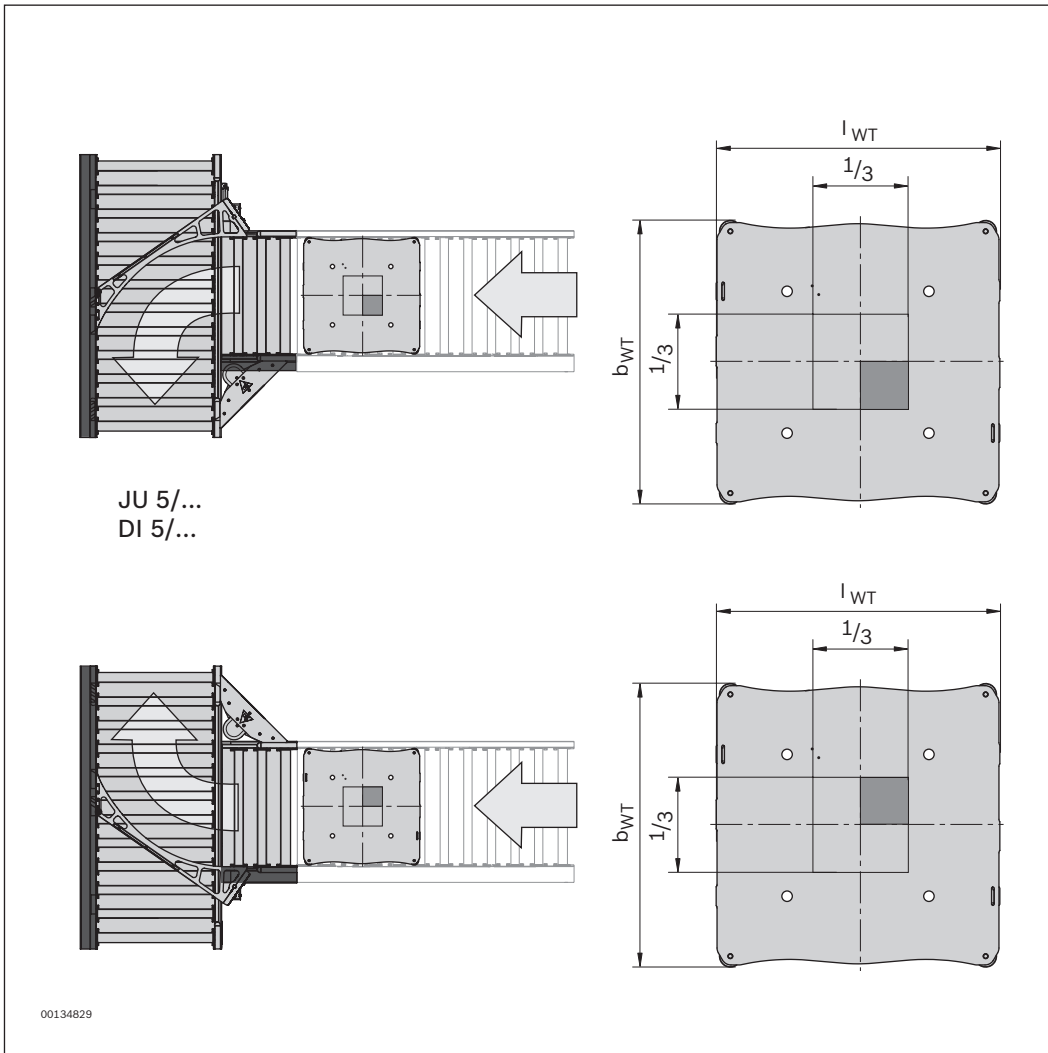

With the illustrated gravity center position transport problems may occur at the transition from the secondary section to the main section. General information on the gravity center position, see page 2-3

Three-way diverter DI 5/XH-3W, DI 5/H-3W



Condition on delivery

- ▶ Ready-to-install
- ▶ Protective covers mounted optionally
(protective covers cannot be ordered separately)

Required accessories

- ▶ Limit switch for linear cylinder

Use

The three-way diverter is a ready-for-operation module for branching off workpiece pallets in two directions or combining from two directions. The king shaft installation for the main or secondary section can be installed on either side. The diverter is controlled as an active element via a pneumatic cylinder ($p = 5 \dots 6$ bar).

Notice: The three-way diverter is not suitable for accumulation operation.

Permissible loads, see page 5-20

Version

- ▶ Reversible operation possible
- ▶ Accumulation operation not permitted
- ▶ Support profile made of anodized aluminum
- ▶ Lateral guide profile made of steel, plastic, or aluminum in an anodized aluminum support
- ▶ Driven via king shaft with bevel gears made of sintered metal
- ▶ Roller spacing $p = 130$
- ▶ Full rollers
- ▶ m_G up to 300 kg (where $v = 9$ m/min)
- ▶ Push in air connection: 6 mm
- ▶ Direct position sensing on the diverter arm and the bolt upon request

Ordering information

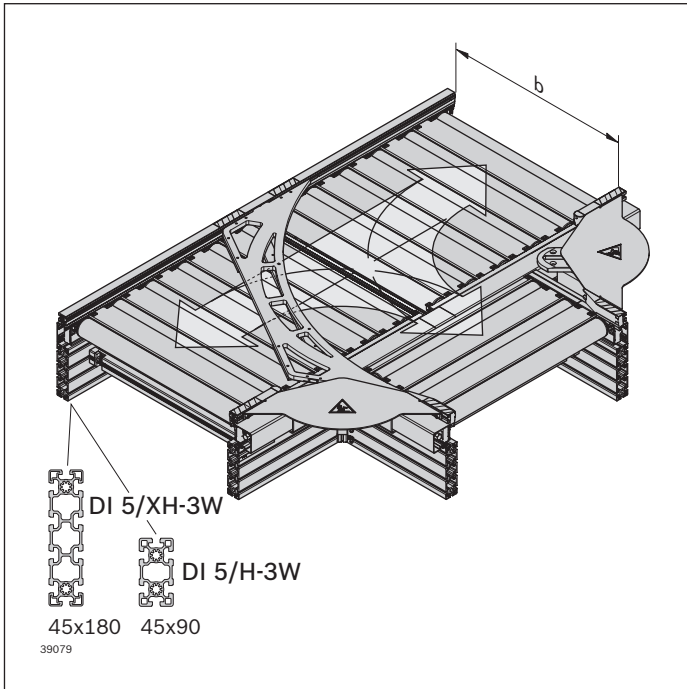

Three-way diverter DI 5/XH-3W, DI 5/H-3W

Product description	Material number
DI 5/XH-3W	3 842 998 807
DI 5/H-3W	3 842 998 808
	b = ... mm
	l_{WT} = ... mm
	LG = ...
	DSM = ...
	DST = ...
	TR = ...
	SC = ...

5

Three-way diverter DI 5/XH-3W, DI 5/H-3W

b (mm)	l_{WT} (mm)	N	LG	DSM	DST	TR	SC
455	455; 650	13	1; 2; 3	1; 2	1; 2	1; 2	1; 2
650	650; 845	15	1; 2; 3	1; 2	1; 2	1; 2	1; 2
845	845; 1040	17	1; 2; 3	1; 2	1; 2	1; 2	1; 2

b = Track width
 l_{WT} = Workpiece pallet length
 (in direction of transport)
 N = Number of rollers, multiplier for
 length ($l = p \times N$), pricing factor
 in the price list

LG = Lateral guide material
 1: Steel
 2: Plastic
 3: Aluminum
 DSM = King shaft installation on
 main section
 1: left
 2: right
 DST = King shaft installation on
 secondary section
 1: left
 2: right

TR = Roller material
 1: Steel, galvanized
 2: Steel, nitrocarburized
 SC = Protective covers
 1: without protective covers
 2: with protective covers

Description of further parameters,
 see page 0-3
 Order examples, see page 5-20

Order examples

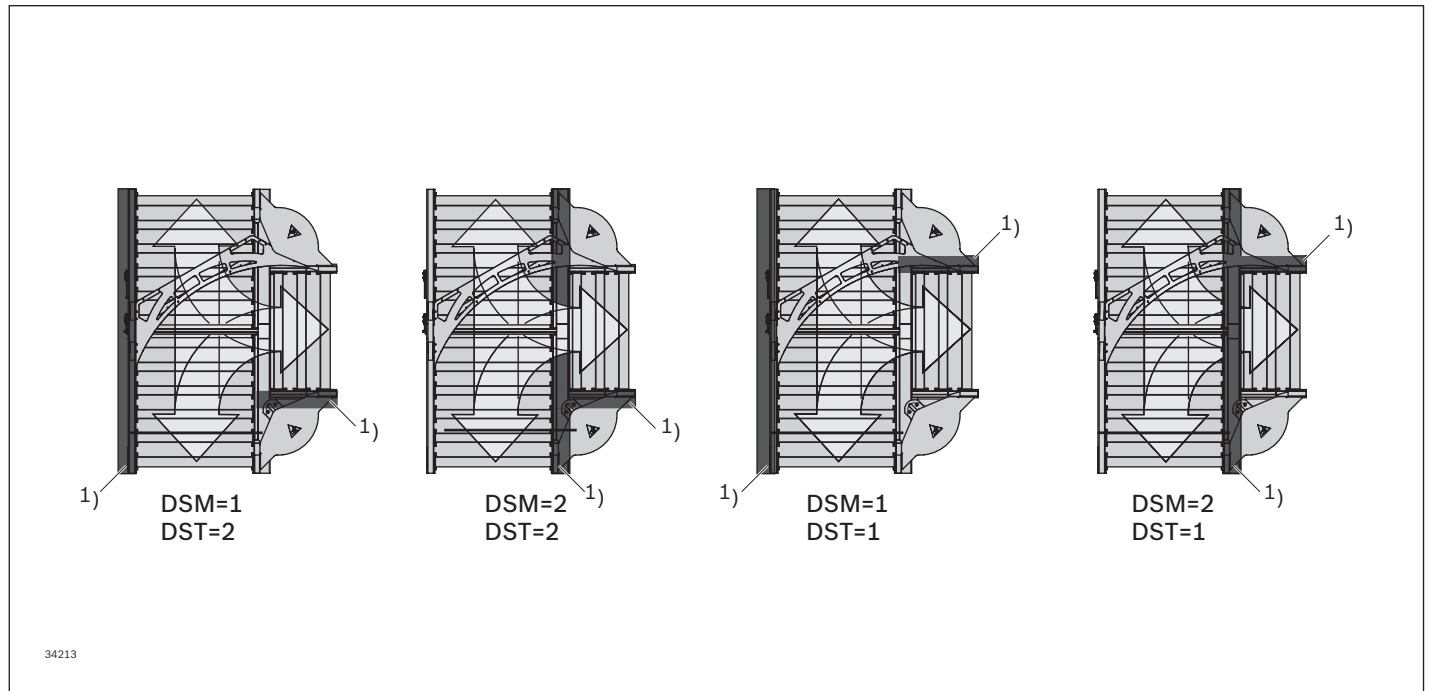

¹⁾ Drive side

Permissible loads

m_G (kg)	v_N (m/min)
max. 260	12
max. 300	9

m_G = total weight of workpiece pallet

Higher weights available on request.
 Can be adapted to different conveyor speeds.
 Diverter arm position inquiry on request.

Dimensions

Diverter DI 5/XH-3W, DI 5/H-3W

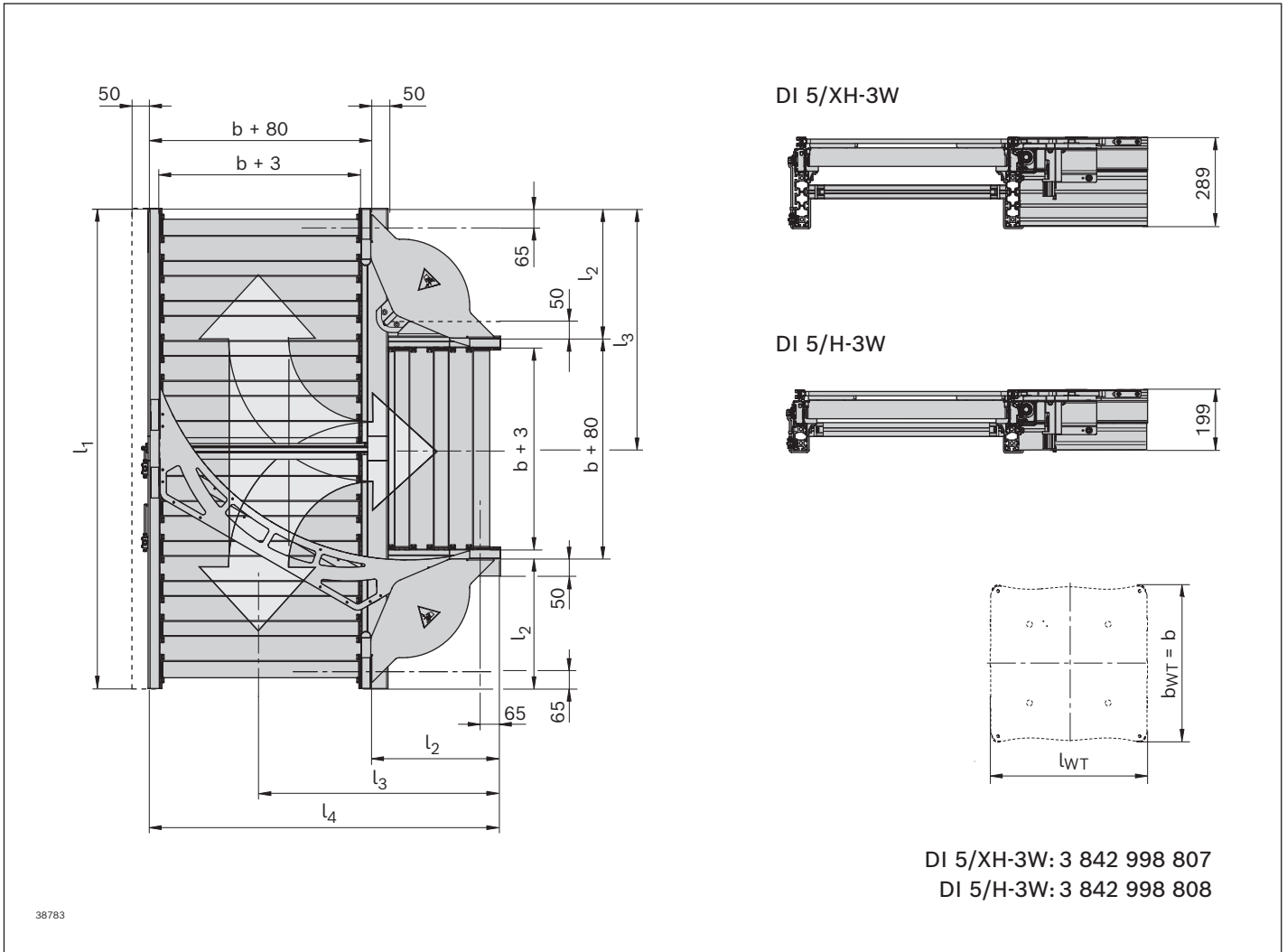

b (mm)	l_{WT} (mm)	N	l₁ (mm)	l₂ (mm)	l₃ (mm)	l₄ (mm)
455	455; 650	13	1300	382.5	650	917.5
650	650; 845	15	1560	415	780	1145
845	845; 1040	17	1820	447	910	1372.5

b = Track width
 l_{WT} = Workpiece pallet length (in direction of transport)
 N = Number of rollers, multiplier for length (l = p × N),
 pricing factor in the price list

l₁ = Length of main section
 l₂ = Length of secondary section
 l₃ = Length of secondary section up to center of main section
 l₄ = Length of secondary section and width of main section

Limits for the permissible gravity center position for the three-way diverter

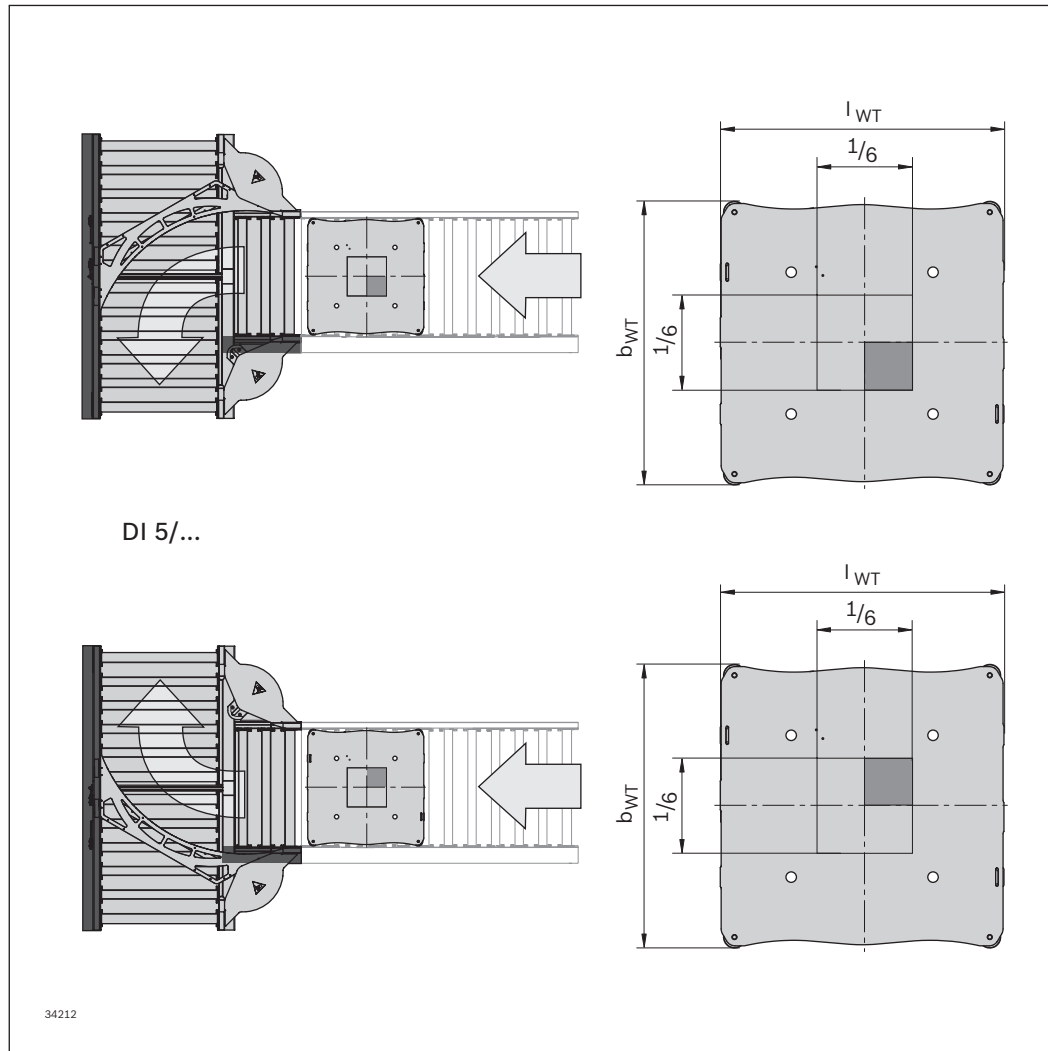

With the illustrated gravity center position transport problems may occur at the transition from the secondary section to the main section. General information on the gravity center position, see page 2-3

Notice: With $b_{WT} = 650$ mm and load center $1/6$, eccentric, $m_G = \text{max. } 200$ kg

Rotary unit DE 5

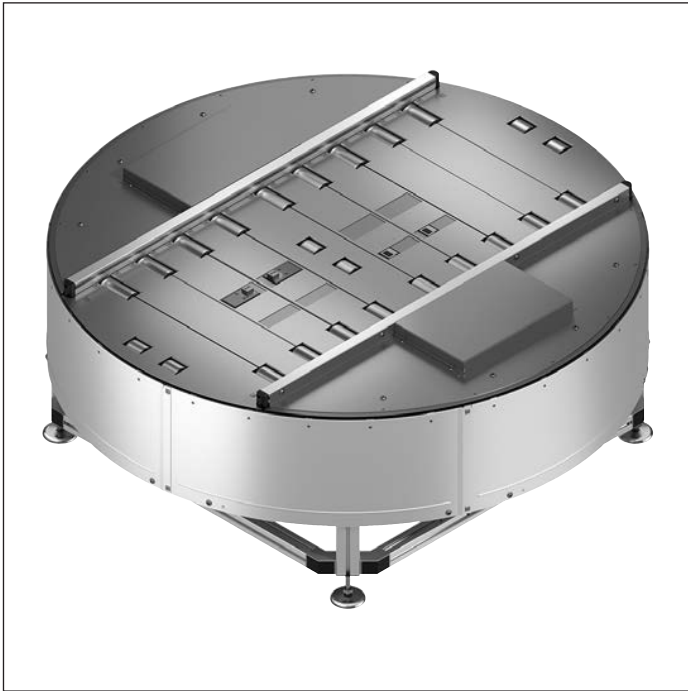

Condition on delivery

- ▶ Ready-to-install incl. supports
- ▶ Protective covers (traversing mechanism and section) mounted optionally; protective covers cannot be ordered separately

Required accessories

- ▶ Anchoring of the rotary unit at the floor for each bolting point:
 - 1x foundation bracket 3 842 146 848
 - 1x dowel 3 842 526 560
 - 2x T-bolts 3 842 528 718
 - 2x flange nuts 3 842 345 081

Sensors

- ▶ For controlling the position (0° / 90° / 180° / 270°)
4x M12 with M8, $S_N = 4$ mm, flush, 3 842 549 812
or alternatively: 4x M12 with M12, $S_N = 4$ mm,
flush 3 842 549 814
- ▶ For stopping and locking the rotary movement (VE)
4x M8 with M8, $S_N = 2$ mm, flush, 3 842 551 761
- ▶ For WT end position and running in of workpiece pallets
with deceleration (ramp) 3x M12 with M12, $S_N = 8$ mm,
not flush 3 842 557 633 or alternatively: 3x M12 with M8,
 $S_N = 8$ mm, not flush 3 842 549 813

Use

The rotary unit is a module for the horizontal rotation and transport of workpiece pallets. With this, branch-offs and crossings are also possible for heavy workpiece pallets (up to 400 kg).

Version

- ▶ Can be used with all standard workpiece pallets in the longitudinal conveyor
- ▶ Incl. section with integrated drive
- ▶ Set roller spacing $p = 130$ mm
- ▶ Reversible operation possible
- ▶ Total weight up to 400 kg, depending on WT size
- ▶ Electric rotary drive with internal motor mounting
- ▶ Rotary range of a total of 270°, divided in 90° steps
- ▶ Compressed air connection: $p = 5 \dots 6$ bar
- ▶ Push in air connection: $\varnothing 6$ mm
- ▶ Rotary movement time:
 - 90 °: 4 s
 - 180 °: 7 s
 - 270 °: 10 s

- ▶ For stopping and locking the workpiece pallet (VE)
2x M8 with M8, $S_N = 2$ mm, flush, 3 842 551 761
- ▶ For end position of the rotary movement 1x M12 with M8,
 $S_N = 4$ mm, flush 3 842 549 811

Frequency converters

- ▶ 1x for the motor for rotary movement
- ▶ 1x for the motor of the belt section of the drive unit (deceleration and start-up of the workpiece pallet)

I/O module (PROFIBUS® or Ethernet)

- ▶ For connection of proximity switches for control of the workpiece pallet
- ▶ For connection of necessary solenoid valves for control of the stop gates

Ordering information

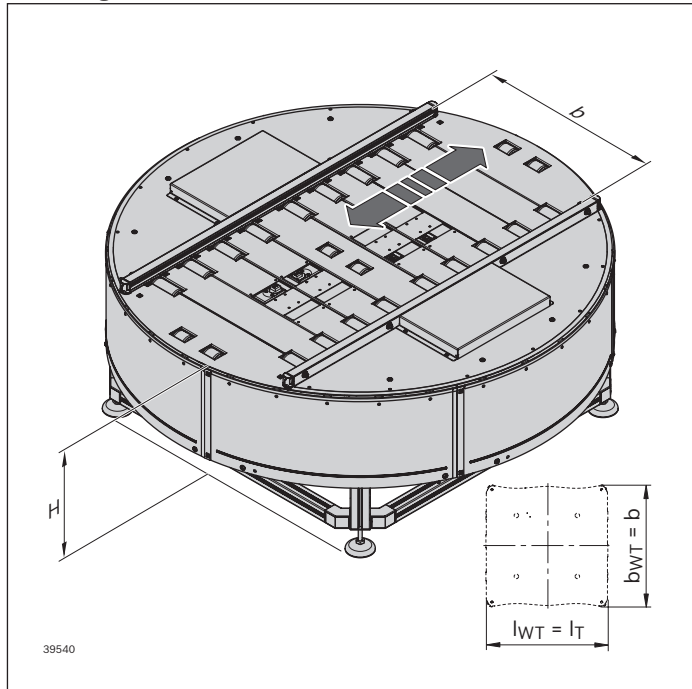

Rotary unit DE 5

Product description	Material number
DE 5	3 842 998 863
	b = ... mm
	l_T = ... mm
	LG = ...
	BG = ...
	TR = ...
	v_N = ... m/min, see page 13-9
	U = ... V, see page 13-8
	f = ... Hz, see page 13-8
	VE = ...
	H = ... mm
	CT = ...

Rotary unit DE 5

b (mm)	l_T (mm)	LG	BG	TR	VE	H (mm)	CT
455	455; 650	1; 2; 3	1; 2	1; 2	0; 1	585 ... 1400	0; 1
650	650; 845	1; 2; 3	1; 2	1; 2	0; 1	585 ... 1400	0; 1
845	845; 1040	1; 2; 3	1; 2	1; 2	0; 1	585 ... 1400	0; 1

b = Track width

l_T = Length in direction of transport

LG = Lateral guide material

1: Steel

2: Plastic

3: Aluminum

BG = Bevel wheel material

1: Plastic

2: Sintered metal

TR = Roller material

1: Steel, galvanized

2: Steel, nitrocarburized

v_N = Nominal speed (m/min);

2*; 4*; 6; 9; 12; 15; 18

= 0 (without gear motor)

VE = Stop gate

0: without

1: with stop gate

H = Transportation height

CT = Protective cover

0: without protective cover

1: with protective cover

* Additional measures may be necessary

Dimensions

Rotary unit without protective cover

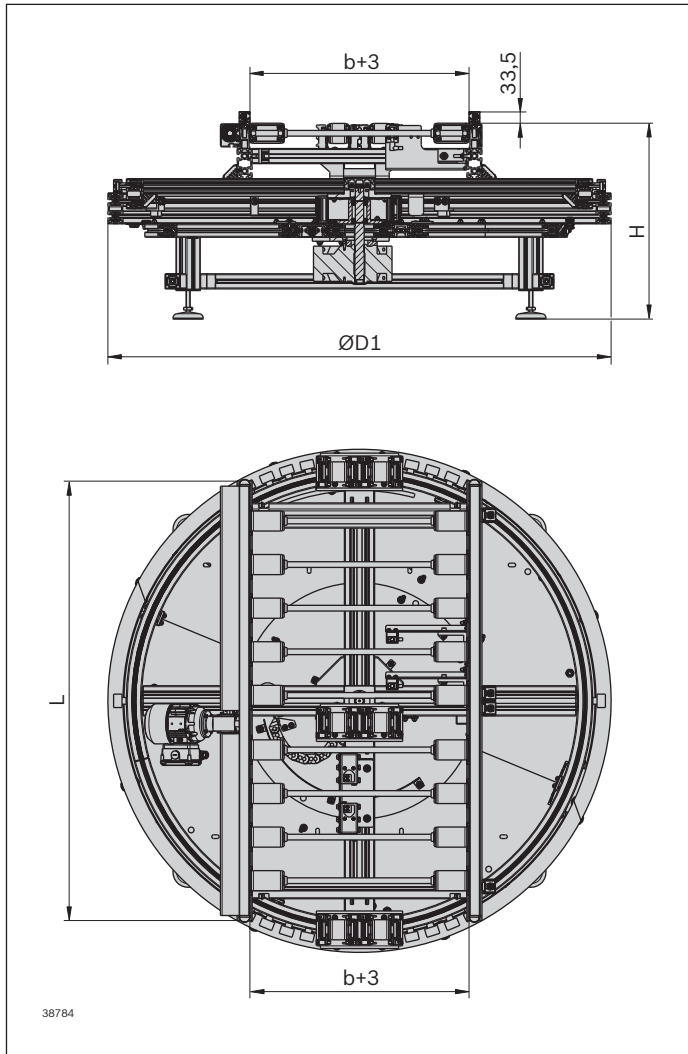

Rotary unit with protective cover

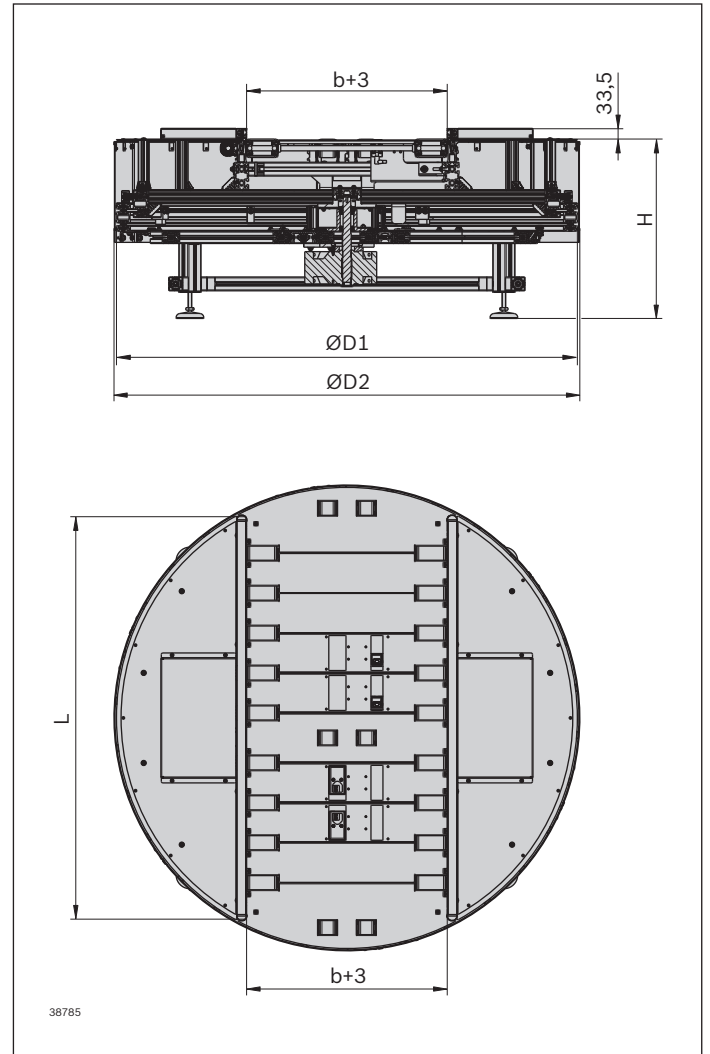

b (mm)	L (mm)	D1 (mm)	D2 (mm)	H (mm)
455	1000	1140	1156	585 ... 1400
650	1310	1500	1516	585 ... 1400
845	1180	1500	1516	585 ... 1400

b = Track width

L = Belt section length

D1 = Ø without protective cover

D2 = Ø with protective cover

H = Transportation height

Distance of connecting conveyor units ST 5 / drive units AS 5

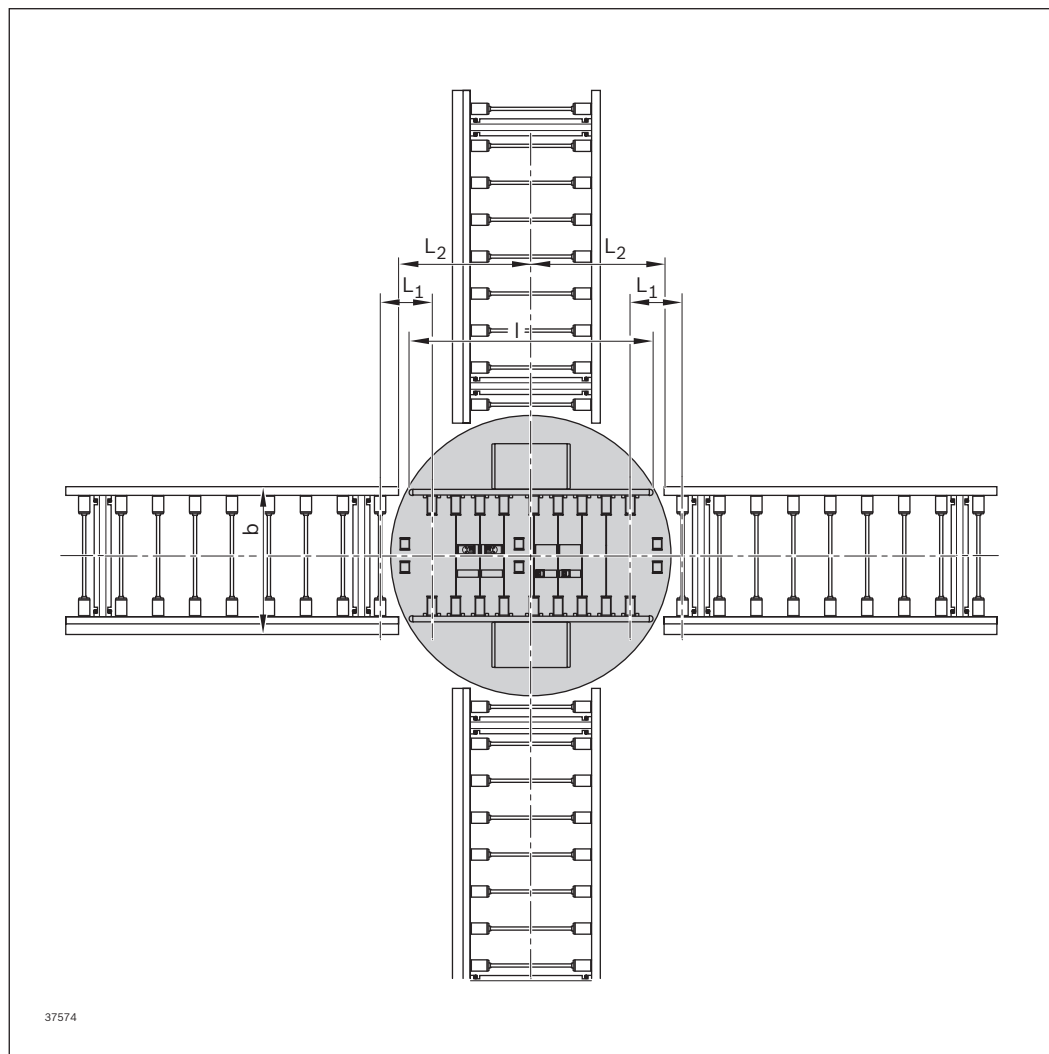

Workpiece pallet WT 5 with central separation

b_{WT} (mm)	L_{WT} (mm)	l (mm)	L_1 (mm)	L_2 (mm)
455	455	1000	240.25 / 243.75	581.5 ¹⁾ / 585
455	650	1000	240.25 / 243.75	581.5 ¹⁾ / 585
650	650	1310	308.75	780
650	845	1310	308.75	780
845	845	1180	373.75	780
845	1040	1180	373.75	780

b_{WT} = Width of workpiece pallet
 l = Length of the drive unit assembled
 at the DE 5

¹⁾ For a layout with curves, diverters and junctions,
 the connection bridges 3 842 998 604 and 3 842 998 605
 must be used as section connected to the rotary unit.

Rotary unit DE 5/FR



Condition on delivery

- ▶ Ready-to-install incl. supports
- ▶ Protective covers (traversing mechanism and section) mounted optionally; protective covers cannot be ordered separately

Required accessories

- ▶ Anchoring of the rotary unit at the floor for each bolting point:
 - 1x foundation bracket 3 842 146 848
 - 1x dowel 3 842 526 560
 - 2x T-bolts 3 842 528 718
 - 2x flange nuts 3 842 345 081

Sensors

- ▶ For controlling the position (0° / 90° / 180° / 270°)
 4x M12 with M8, $S_N = 4$ mm, flush, 3 842 549 812
 or alternatively: 4x M12 with M12, $S_N = 4$ mm,
 flush 3 842 549 814
- ▶ For stopping and locking the rotary movement (VE)
 4x M8 with M8, $S_N = 2$ mm, flush, 3 842 551 761
- ▶ For WT end position and running in of workpiece pallets
 with deceleration (ramp) 3x M12 with M12, $S_N = 8$ mm,
 not flush 3 842 557 633 or alternatively: 3x M12 with
 M8, $S_N = 8$ mm, not flush 3 842 549 813

Use

The rotary unit is a module for the horizontal rotation and transport of workpiece pallets. With this, branch-offs and crossings are also possible for heavy workpiece pallets (up to 400 kg).

Version

- ▶ Can be used with all standard workpiece pallets in the longitudinal conveyor
- ▶ Incl. section with integrated drive
- ▶ Set roller spacing $p = 130$ mm
- ▶ Reversible operation possible
- ▶ Total weight up to 400 kg, depending on WT size
- ▶ Electric rotary drive with internal motor mounting
- ▶ Rotary range of a total of 270°, divided in 90° steps
- ▶ Compressed air connection: $p = 5 \dots 6$ bar
- ▶ Push in air connection: $\varnothing 6$ mm
- ▶ Rotary movement time:
 - 90 °: 4 s
 - 180 °: 7 s
 - 270 °: 10 s

- ▶ For stopping and locking the workpiece pallet (VE)
 2x M8 with M8, $S_N = 2$ mm, flush, 3 842 551 761
- ▶ For end position of the rotary movement 1x M12
 with M8, $S_N = 4$ mm, flush 3 842 549 811

Frequency converters

- ▶ 1x for the motor for rotary movement
- ▶ 1x for the motor of the belt section of the drive unit (deceleration and start-up of the workpiece pallet)

I/O module (PROFIBUS® or Ethernet)

- ▶ For connection of proximity switches for control of the workpiece pallet
- ▶ For connection of necessary solenoid valves for control of the stop gates

Ordering information

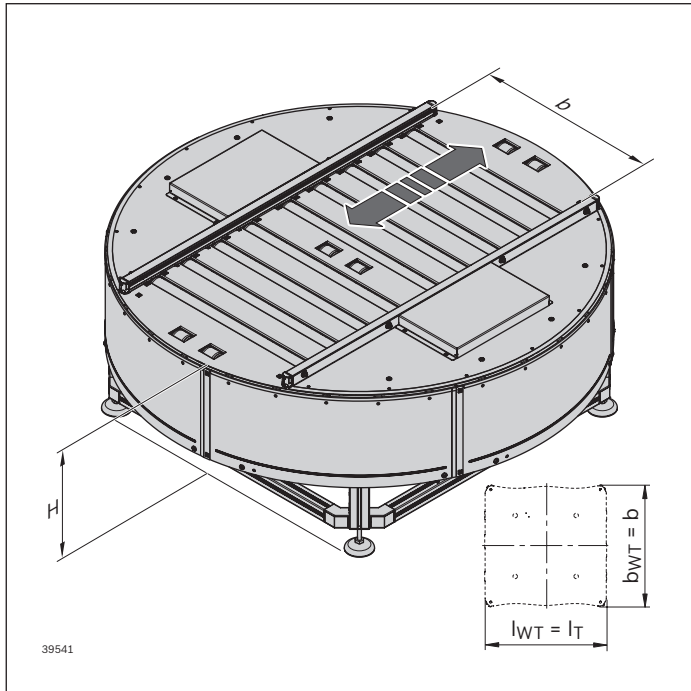

Rotary unit DE 5/FR

Product description	Material number
DE 5/FR	3 842 998 862
	b = ... mm
	l_T = ... mm
	LG = ...
	BG = ...
	TR = ...
	v_N = ... m/min, see page 13-9
	U = ... V, see page 13-8
	f = ... Hz, see page 13-8
	H = ... mm
	CT = ...

Rotary unit DE 5/FR

b (mm)	l_T (mm)	LG	BG	TR	H (mm)	CT
455	455; 650	1; 2; 3	1; 2	1; 2	585 ... 1400	0; 1
650	650; 845	1; 2; 3	1; 2	1; 2	585 ... 1400	0; 1
845	845; 1040	1; 2; 3	1; 2	1; 2	585 ... 1400	0; 1

b = Track width

l_T = Length in direction of transport

LG = Lateral guide material

1: Steel

2: Plastic

3: Aluminum

BG = Bevel wheel material

1: Plastic

2: Sintered metal

TR = Roller material

1: Steel, galvanized

2: Steel, nitrocarburized

v_N = Nominal speed (m/min);

2*; 4*; 6; 9; 12; 15; 18

= 0 (without gear motor)

H = Transportation height

CT = Protective cover

0: without protective cover

1: with protective cover

* Additional measures may be necessary

Dimensions

Rotary unit without protective cover

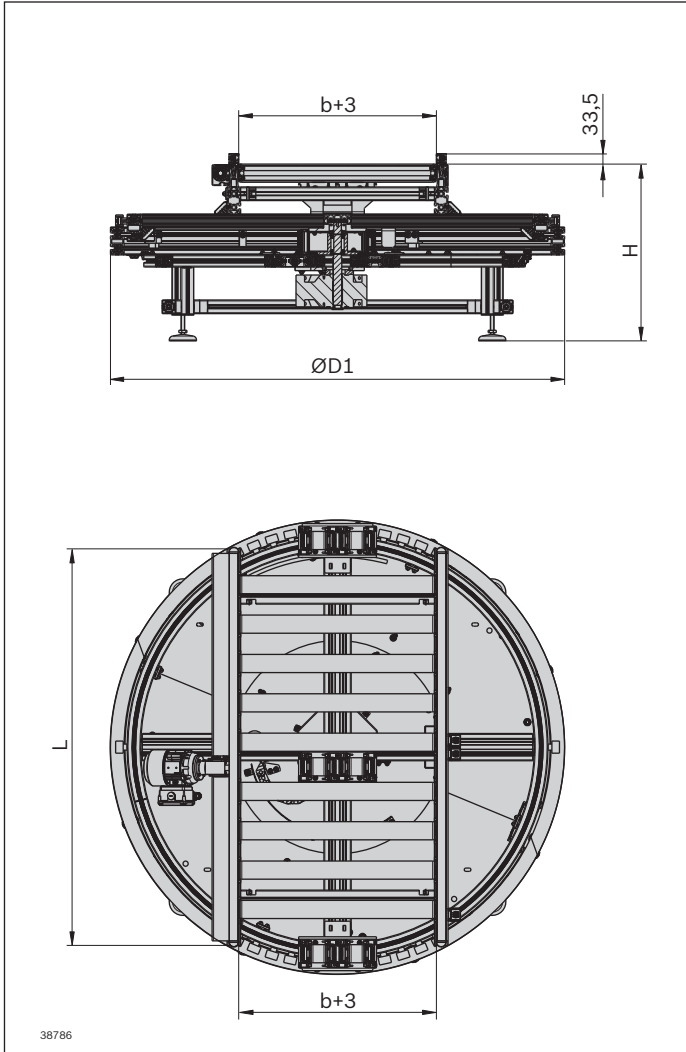

Rotary unit with protective cover

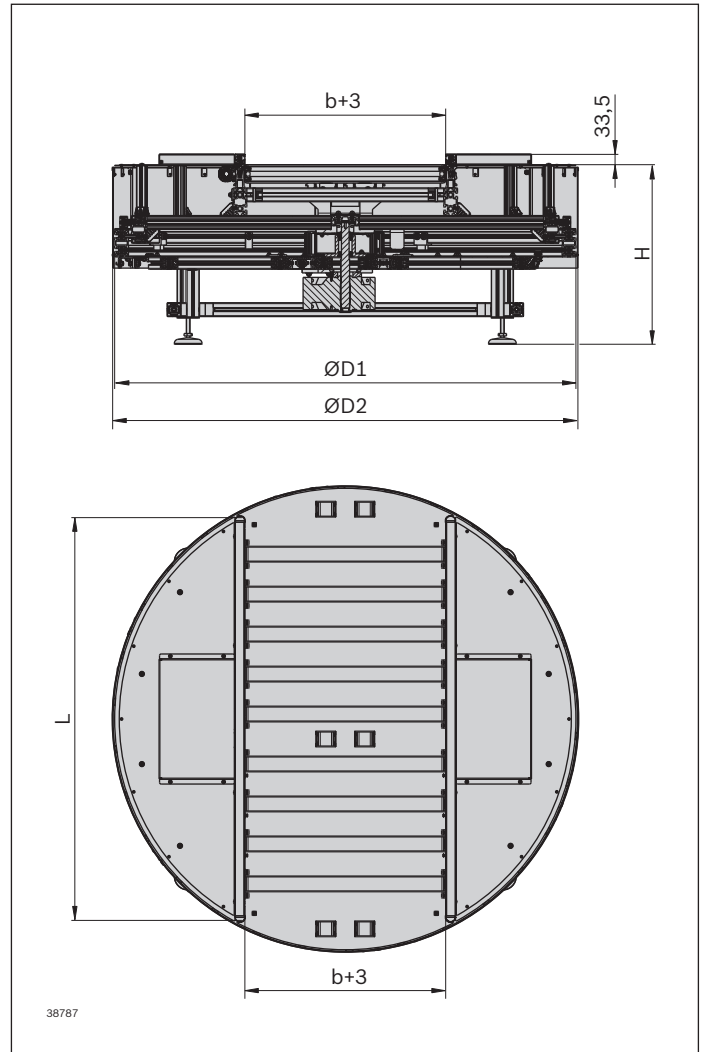

5

b (mm)	L (mm)	D1 (mm)	D2 (mm)	H (mm)
455	1000	1140	1156	585 ... 1400
650	1310	1500	1516	585 ... 1400
845	1180	1500	1516	585 ... 1400

b = Track width
 L = Belt section length
 D1 = Ø without protective cover

D2 = Ø with protective cover
 H = Transportation height

Distance of connecting conveyor units ST 5 / drive units AS 5

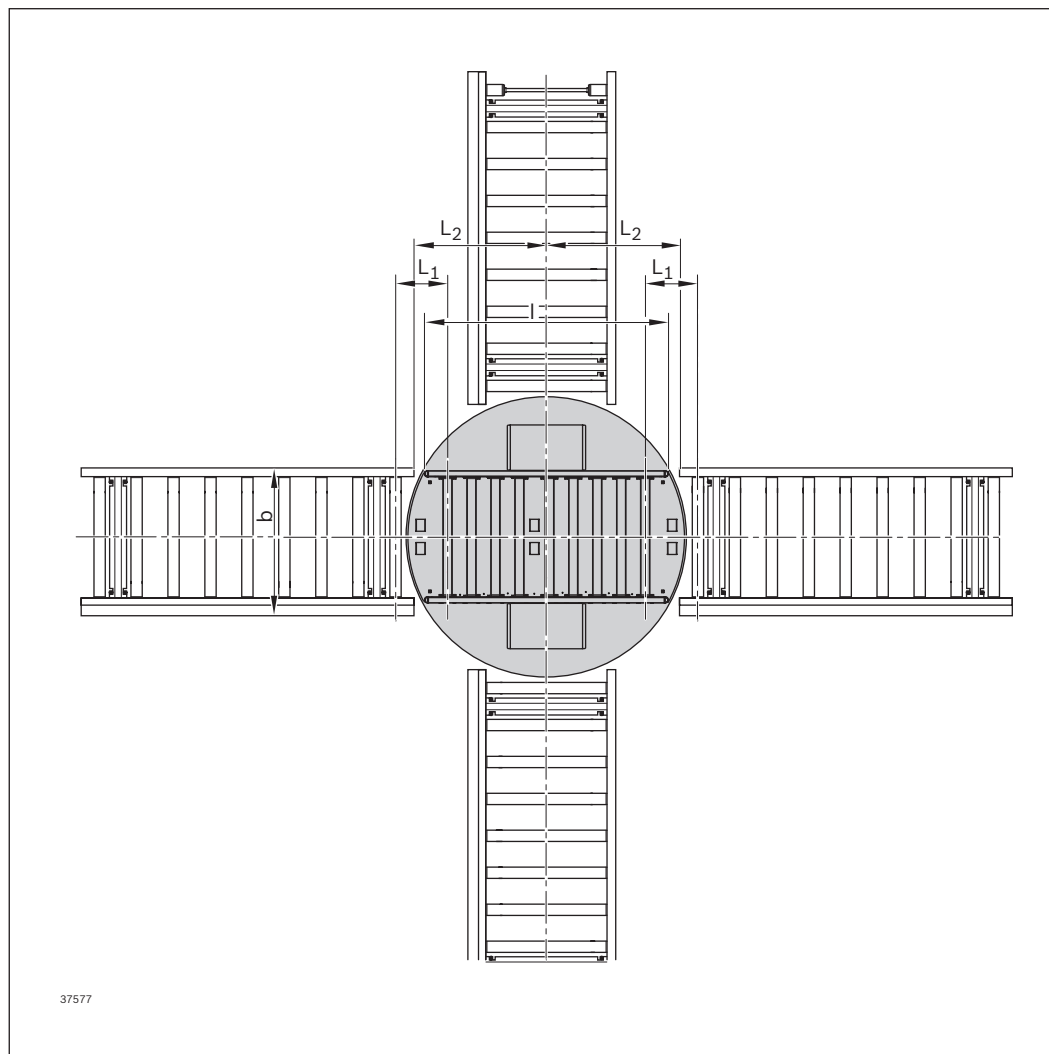

Distance of connecting conveyor units ST 5 / drive units AS 5

Workpiece pallet WT 5 with central separation

b_{WT} (mm)	L_{WT} (mm)	l (mm)	L_1 (mm)	L_2 (mm)
455	455	1000	240.25 / 243.75	581.5 ¹⁾ / 585
455	650	1000	240.25 / 243.75	581.5 ¹⁾ / 585
650	650	1310	308.75	780
650	845	1310	308.75	780
845	845	1180	373.75	780
845	1040	1180	373.75	780

b_{WT} = Width of workpiece pallet
 l = Length of the drive unit assembled
 at the DE 5

¹⁾ For a layout with curves, diverters and junctions,
 the connection bridges 3 842 998 604 and 3 842 998 605
 must be used as section connected to the rotary unit.

Rotary unit DE 5/OC



Condition on delivery

- ▶ Ready-to-install incl. supports
- ▶ Protective covers (traversing mechanism and section) mounted optionally; protective covers cannot be ordered separately

Required accessories

- ▶ Anchoring of the rotary unit at the floor for each bolting point:
 - 1x foundation bracket 3 842 146 848
 - 1x dowel 3 842 526 560
 - 2x T-bolts 3 842 528 718
 - 2x flange nuts 3 842 345 081

Sensors

- ▶ For controlling the position (0° / 90° / 180° / 270°)
4x M12 with M8, $S_N = 4$ mm, flush, 3 842 549 812
or alternatively: 4x M12 with M12, $S_N = 4$ mm,
flush 3 842 549 814
- ▶ For stopping and locking the rotary movement (VE)
4x M8 with M8, $S_N = 2$ mm, flush, 3 842 551 761
- ▶ For WT end position and running in of workpiece pallets
with deceleration (ramp) 3x M12 with M12, $S_N = 8$ mm,
not flush 3 842 557 633 or alternatively: 3x M12 with
M8, $S_N = 8$ mm, not flush 3 842 549 813

Use

The rotary unit is a module for the horizontal rotation and transport of workpiece pallets. With this, branch-offs and crossings are also possible for heavy workpiece pallets (up to 400 kg).

Version

- ▶ Can be used with all standard workpiece pallets in the longitudinal conveyor
- ▶ Incl. section with integrated drive
- ▶ Set roller spacing $p = 130$ mm
- ▶ Reversible operation possible
- ▶ Total weight up to 400 kg, depending on WT size
- ▶ Electric rotary drive with internal motor mounting
- ▶ Rotary range of a total of 270°, divided in 90° steps
- ▶ Compressed air connection: $p = 5 \dots 6$ bar
- ▶ Push in air connection: $\varnothing 6$ mm
- ▶ Rotary movement time:
 - 90 °: 4 s
 - 180 °: 7 s
 - 270 °: 10 s

- ▶ For stopping and locking the workpiece pallet (VE)
2x M8 with M8, $S_N = 2$ mm, flush, 3 842 551 761
- ▶ For end position of the rotary movement 1x M12 with M8,
 $S_N = 4$ mm, flush 3 842 549 811

Frequency converters

- ▶ 1x for the motor for rotary movement
- ▶ 1x for the motor of the belt section of the drive unit (deceleration and start-up of the workpiece pallet)

I/O module (PROFIBUS® or Ethernet)

- ▶ For connection of proximity switches for control of the workpiece pallet
- ▶ For connection of necessary solenoid valves for control of the stop gates

Ordering information

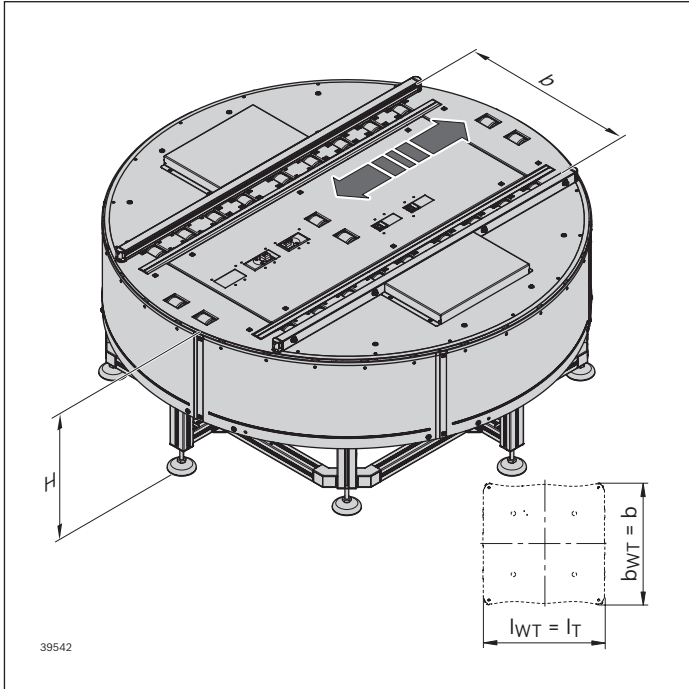

Rotary unit DE 5/OC

Product description	Material number
DE 5/OC	3 842 998 864
	b = ... mm
	l_T = ... mm
	LG = ...
	BG = ...
	DD = ...
	TR = ...
	v_N = ... m/min, see page 13-9
	U = ... V, see page 13-8
	f = ... Hz, see page 13-8
	VE = ...
	H = ... mm
	CT = ...

Rotary unit DE 5/OC

b (mm)	l_T (mm)	LG	BG	DD	TR	VE	H (mm)	CT
455	455; 650	1; 2; 3	1; 2	1; 3	1; 2	0; 1	585 ... 1400	0; 1
650	650; 845	1; 2; 3	1; 2	1; 3	1; 2	0; 1	585 ... 1400	0; 1
845	845; 1040	1; 2; 3	1; 2	1; 3	1; 2	0; 1	585 ... 1400	0; 1

- | | | |
|--|------------------------------------|-----------------------------|
| b = Track width | DD = Drive | VE = Stop gate |
| l_T = Length in direction of transport | 1: on one side with 1 gear motor | 0: without |
| LG = Lateral guide material | 3: on two sides with 2 gear motors | 1: with stop gate |
| 1: Steel | TR = Roller material | H = Transportation height |
| 2: Plastic | 1: Steel, galvanized | CT = Protective cover |
| 3: Aluminum | 2: Steel, nitrocarburized | 0: without protective cover |
| BG = Bevel wheel material | v_N = Nominal speed (m/min); | 1: with protective cover |
| 1: Plastic | 2*; 4*; 6; 9; 12; 15; 18 | |
| 2: Sintered metal | = 0 (without gear motor) | |
- * Additional measures may be necessary

Dimensions

Rotary unit without protective cover

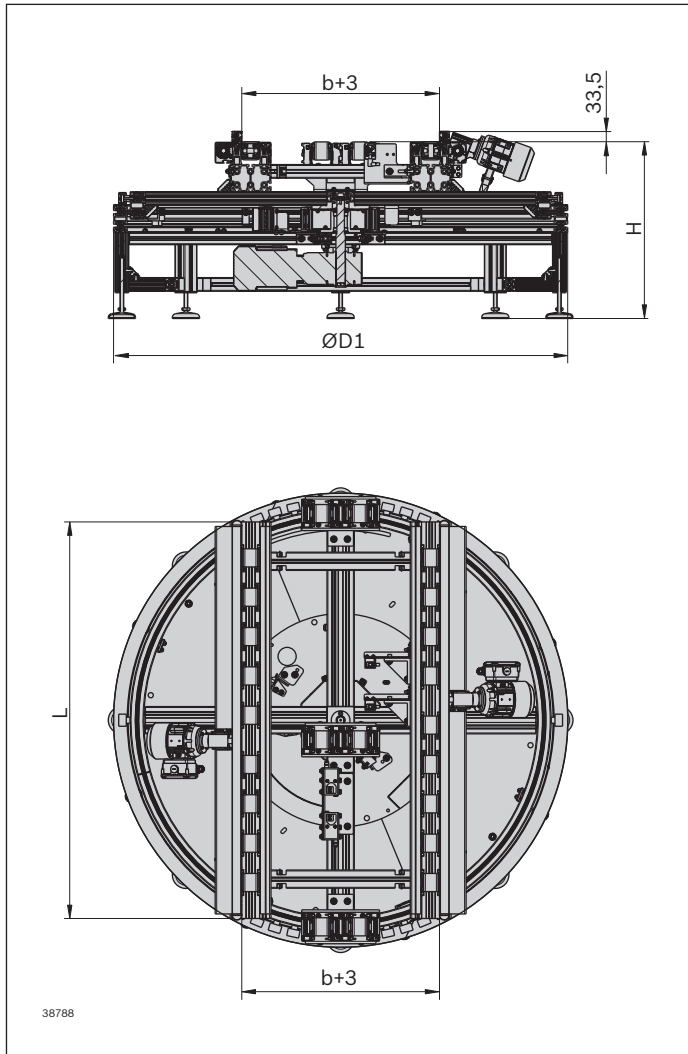

Rotary unit with protective cover

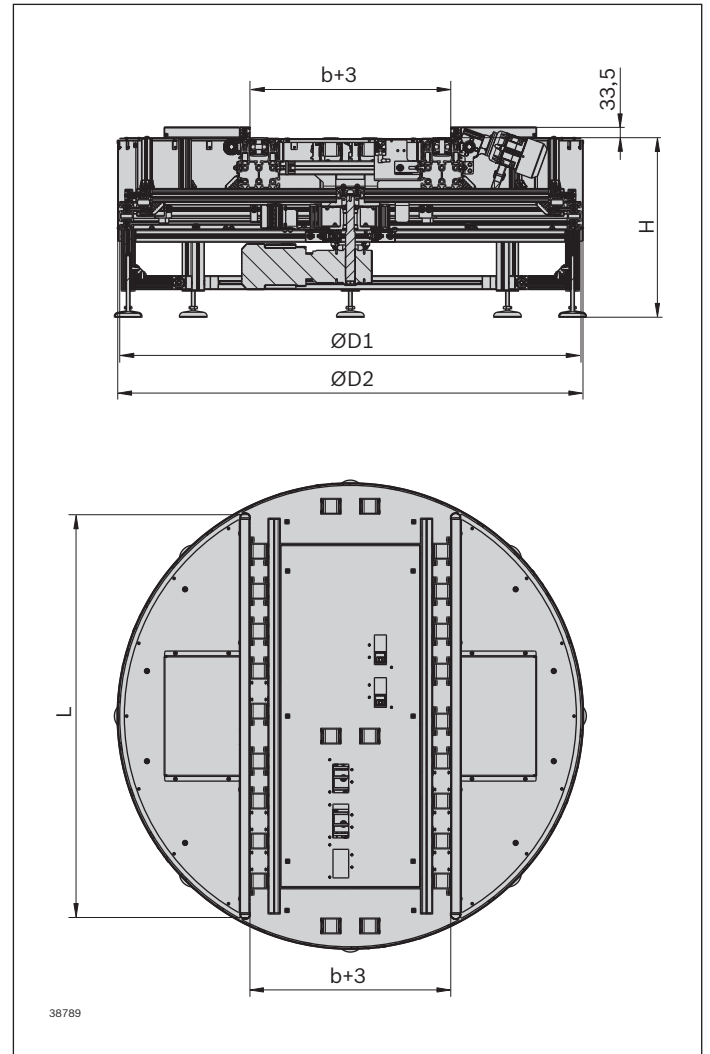

5

b (mm)	L (mm)	D1 (mm)	D2 (mm)	H (mm)
455	1000	1140	1156	585 ... 1400
650	1320	1500	1516	585 ... 1400
845	1180	1500	1516	585 ... 1400

b = Track width

L = Belt section length

D1 = Ø without protective cover

D2 = Ø with protective cover

H = Transportation height

Distance of connecting conveyor units ST 5 / drive units AS 5

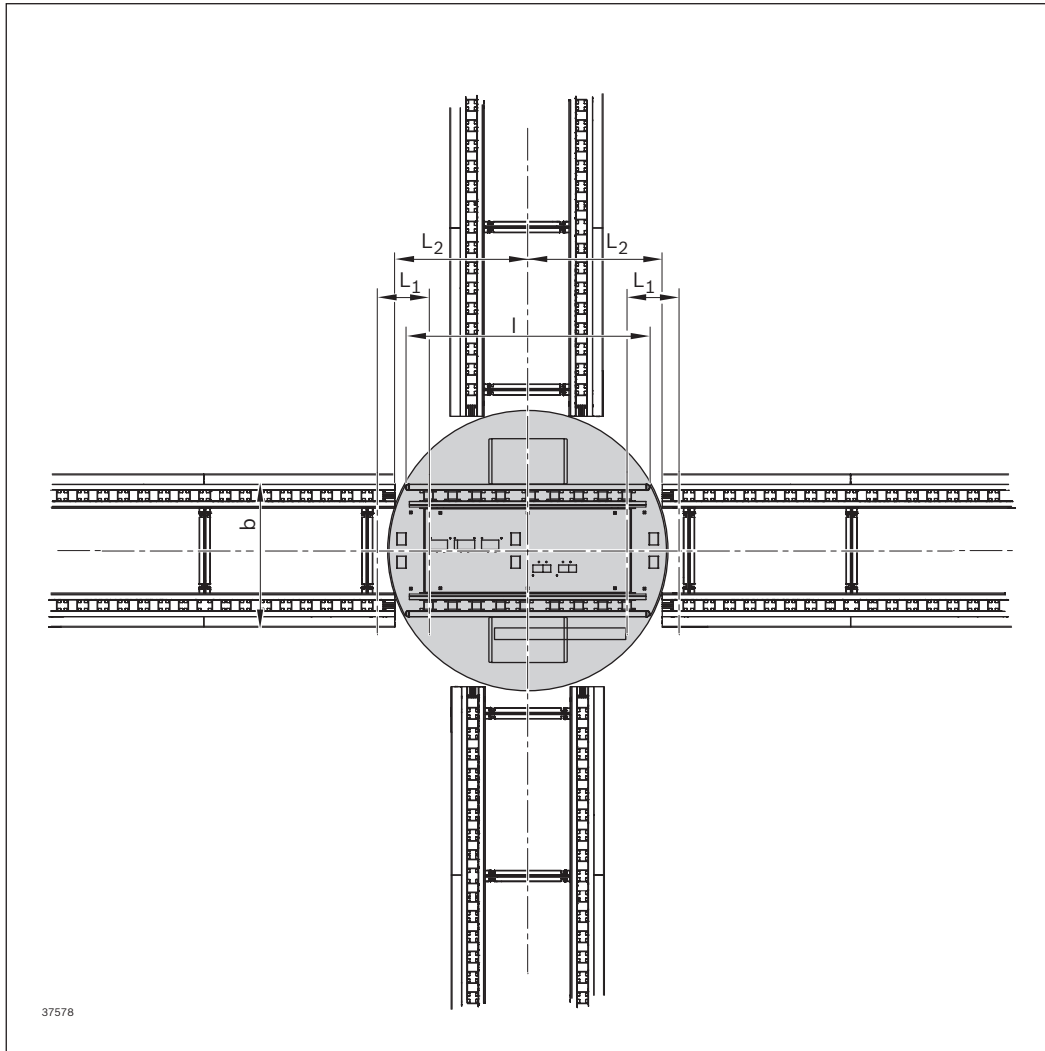

Workpiece pallet WT 5 with central separation

b_{WT} (mm)	L_{WT} (mm)	l (mm)	L_1 (mm)	L_2 (mm)
455	455	1000	240.25 / 243.75	581.5 ¹⁾ / 585
455	650	1000	240.25 / 243.75	581.5 ¹⁾ / 585
650	650	1310	308.75	780
650	845	1310	308.75	780
845	845	1180	373.75	780
845	1040	1180	373.75	780

b_{WT} = Width of workpiece pallet
 l = Length of the drive unit assembled
 at the DE 5

¹⁾ For a layout with curves, diverters and junctions,
 the connection bridges 3 842 998 604 and 3 842 998 605
 must be used as section connected to the rotary unit.

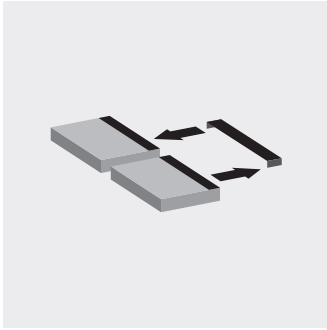

Transverse conveyor

Design	6-2
Lift transverse unit HQ 5	6-4
Lift transverse unit HQ 5/XH and HQ 5/H	6-7
Damper DA 5/200, DA 5/1000	6-14
Connection kit for connecting the transverse section	6-16
Connection bridge	6-18
Protective covers for lift transverse unit HQ 5	6-20
Cover for lateral guide of lift transverse unit HQ 5	6-22

Design

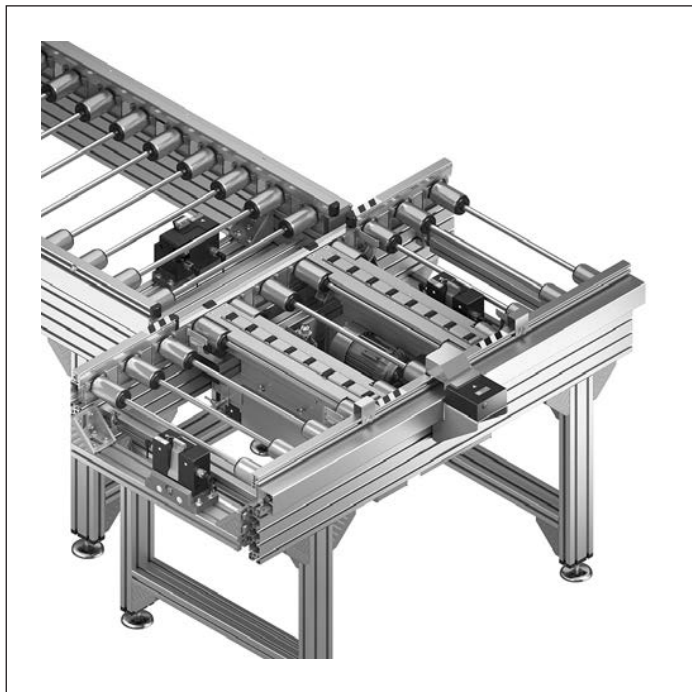

Transverse conveyors are used to branch workpiece pallet paths into the individual processing stations. When changing from a longitudinal conveyor to a transverse conveyor and vice versa, the workpiece pallet also changes its orientation with regard to its direction of transport.

Notice:

- ▶ Minimum speed of transverse section: 6 m/min
- ▶ Traveling through curves/diverters/junctions is only possible in longitudinal conveyor direction (see arrow on workpiece pallet)!
- ▶ Accumulation is not permitted on HQ 5
- ▶ Permissible load according to the number of rollers, see page 2-9

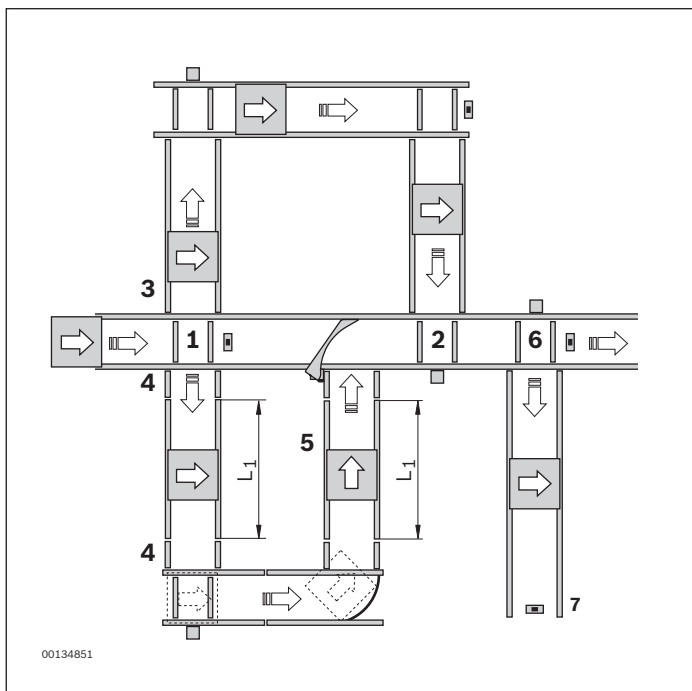

HQ 5 infeeding and outfeeding options:

- 1 Outfeeding to both sides
- 2 Infeeding from just one side, see page 6-14
- 3 Connection of the transverse section (standard section) in a circuit with 4 lift transverse units, see page 6-18
- 4 Connection of the transverse section (2x connection bridge + standard section) with parallel use of lift transverse unit and curve/diverter/junction, see page 6-18
L₁: same section length
- 5 Rotation of the workpiece pallet by 90° with the combination of lift transverse unit and curve/diverter
- 6 Infeeding and outfeeding to dead end section
- 7 Dead end section with stop gate as end stop

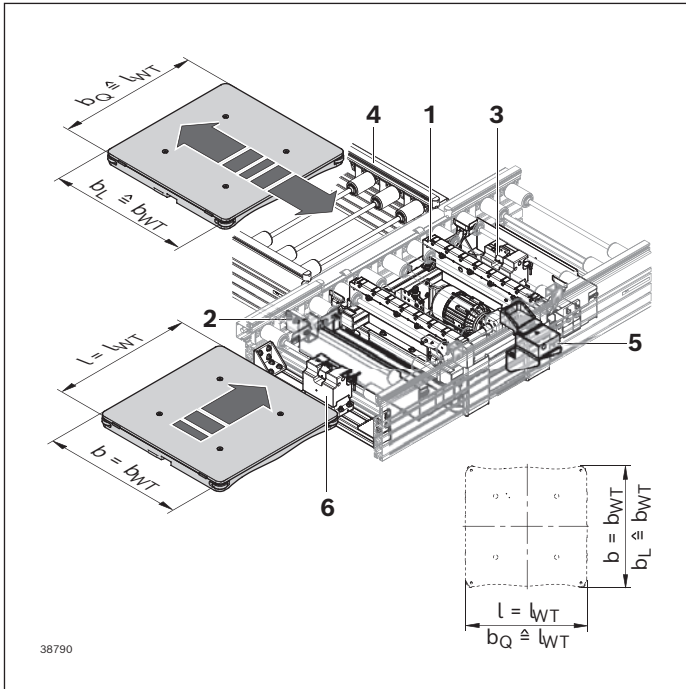

Transverse conveyor modular units include the following components:

- 1** Lift transverse unit HQ 5, see page 6-4
- 2** Connection kit for connecting the transverse section, see page 6-16
- 3** Stop gate VE 5/D-300 (see page 9-6), VE 5/D-301 (see page 9-9), VE 5/D-1000 (see page 9-12) or VE 5/D-1000-E (see page 9-15) to stop the WT when outfeeding
- 4** Connection bridge (see page 6-18) to compensate for length with parallel use of lift transverse unit and curve/diverter/junction
- 5** Damper DA 5/... to stop the WT when infeeding, see page 6-14
- 6** Stop gate, if required, to pre-stop the workpiece pallet, see page 9-6

Lift transverse unit HQ 5



Scope of delivery

- ▶ Including fastening material for mounting the HQ 5 in conveyor sections ST 5/XH, ST 5/H and in the drive modules AS 5/XH, AS 5/H, see page 3-4
- ▶ Incl. support rollers included in all configurations up to $b_L = 845$ mm with $p = 130$ mm or $p = 195$ mm, as there are no problems with the conveyor trench
- ▶ Incl. protective covers for the lifting mechanism and roller section
- ▶ Incl. cover on passive or active side depending on the selection of parameter OFD and use of support rollers
- ▶ Incl. guide piece and warning label

Required accessories

- ▶ Stop gate VE 5/200, VE 5/D-300, VE 5/D-301, VE 5/D-1000 or VE 5/D-1000-E, see page 9-3ff
- ▶ 2x switch bracket SH 2/U-H (3 842 537 289) for position inquiry top and bottom, see page 9-22
- ▶ Sensor application matrix, see page 9-21

Use

- ▶ The lift transverse unit is a module for branching transport. It lifts the workpiece pallet and moves it transversely to the original conveying direction via a driven roller section.

Notice:

- ▶ This lift transverse unit is delivered without section.
- ▶ Note the orientation of the workpiece pallet after branching.
- ▶ When using the interface to SEW, the motor is in the direction of transport before HQ 5.

Version

- ▶ Can be used with all workpiece pallets WT 5
- ▶ The transport level of the transverse section is 4.5 mm above the transport level of the longitudinal section
- ▶ Protective case can also be removed in the case of low conveyor heights
- ▶ Compressed air connection: 5 ... 6 bar
- ▶ Push in air connection: 6 mm
- ▶ Drive possible with AB 5, see page 3-21

Condition on delivery

- ▶ Assembled

Recommended accessories

- ▶ Cover for the lateral guide, see page 6-22
- ▶ For position inquiry WT sensor 3 842 545 972, see page 9-19

Ordering information

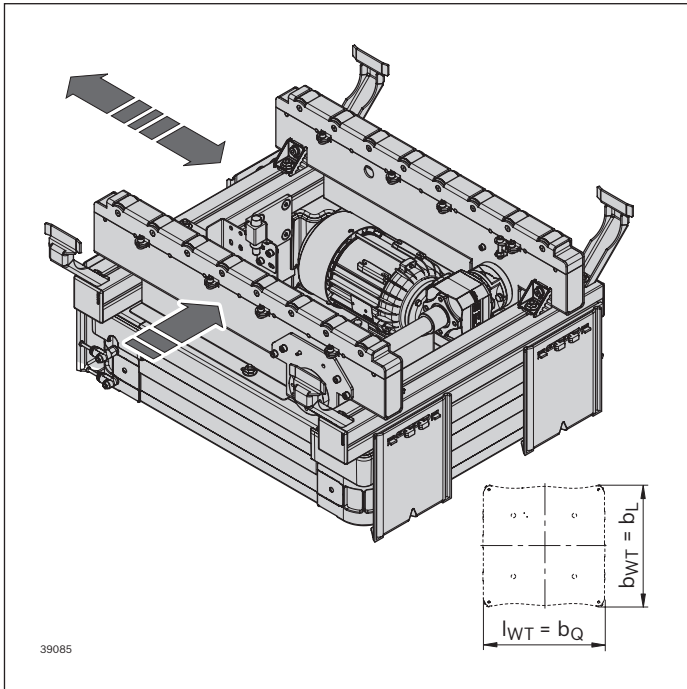

Lift transverse unit HQ 5

Product description	Material number
HQ 5	3 842 998 930
	$b_L = \dots$ mm
	$b_Q = \dots$ mm
	$p = \dots$ mm
	OFD = ...
	DSM = ...
	CT = ...
	GM = ...
	$v_N = \dots$ m/min, see page 13-9
	U = ... V, see page 13-8
	f = ... Hz, see page 13-8
	AT = ...

6

Lift transverse unit HQ 5

b_L (mm)	b_Q (mm)	p (mm)	OFD	DSM	CT	GM	v_N (m/min)	AT
455	455	130	1; 2; 3	1; 2	0; 1	0; 1; 2	6; 9; 12	K; S
455	650	130; 195	1; 2; 3	1; 2	0; 1	0; 1; 2	6; 9; 12	K; S
650	650	130; 195	1; 2; 3	1; 2	0; 1	0; 1; 2	6; 9; 12	K; S
650	845	130; 195; 260	1; 2; 3	1; 2	0; 1	0; 1; 2	6; 9; 12	K; S
845	845	130; 195; 260	1; 2; 3	1; 2	0; 1	0; 1; 2	6; 9; 12	K; S
845	1040	130; 195; 260; 325	1; 2; 3	1; 2	0; 1	0; 1; 2	6; 9; 12	K; S

- b_L = Track width (longitudinal conveyor)
 - b_Q = Track width (transverse conveyor)
 - p = Roller spacing (pitch)
 - OFD = Direction of the outfeed
 - 1: left
 - 2: right
 - 3: left and right
 - DSM = King shaft installation on main section
 - 1: left
 - 2: right
 - GM = Gear motor
 - 0: without (interface SW17)
 - 1: with gear motor SW17
 - 2: without (interface to connection SEW, round shaft $\varnothing 20$)
 - CT = Protective case
 - 0: without protective case
 - 1: with protective case
 - v_N = Nominal speed
 - U = 0, $v_N > 0$: with gear, without motor
 - $v_N = 0$: without motor and gear
 - AT = Motor connection
 - K: with terminal box
 - S: with cable/plug
- Description of further parameters, see page 0-3

Dimensions

Lift transverse unit HQ 5

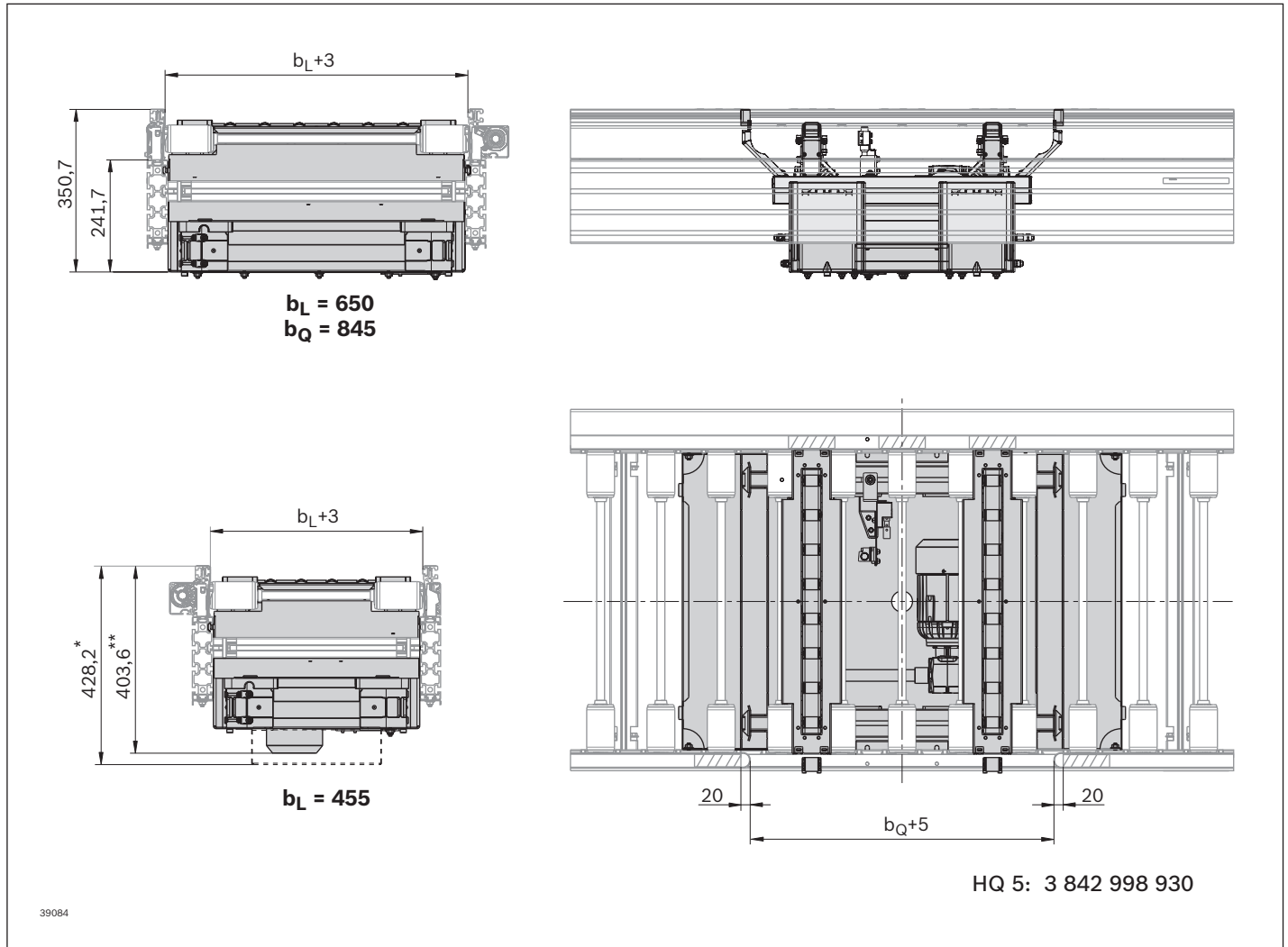

* with protective case

** without protective case

Lift transverse unit HQ 5/XH and HQ 5/H



Use

- ▶ The lift transverse unit is a ready-for-operation module for branching transport. It lifts the workpiece pallet from the rollers and moves it transversely to the original conveying direction via a driven roller section

Notice: Note the orientation of the workpiece pallet after branching.

Version

- ▶ Can be used with all workpiece pallets WT 5
- ▶ The transport level of the transverse section is 4.5 mm above the transport level of the longitudinal section
- ▶ Protective case can also be removed in the case of low conveyor heights
- ▶ Compressed air connection: 5 ... 6 bar
- ▶ Push in air connection: 6 mm

Scope of delivery

- ▶ Incl. conveyor unit ST 5/XH or ST 5/H, see page 4-3

Required accessories

- ▶ Stop gate VE 5/200, VE 5/D-300, VE 5/D-301, VE 5/D-1000 or VE 5/D-1000-E, see page 9-3ff
- ▶ 2x switch bracket SH 2/U-H (3 842 537 289) for position inquiry top and bottom, see page 9-22
- ▶ Sensor application matrix, see page 9-21

Condition on delivery

- ▶ Assembled

Recommended accessories

- ▶ Cover for the lateral guide, see page 6-22
- ▶ For position inquiry WT sensor 3 842 545 972, see page 9-19

Ordering information

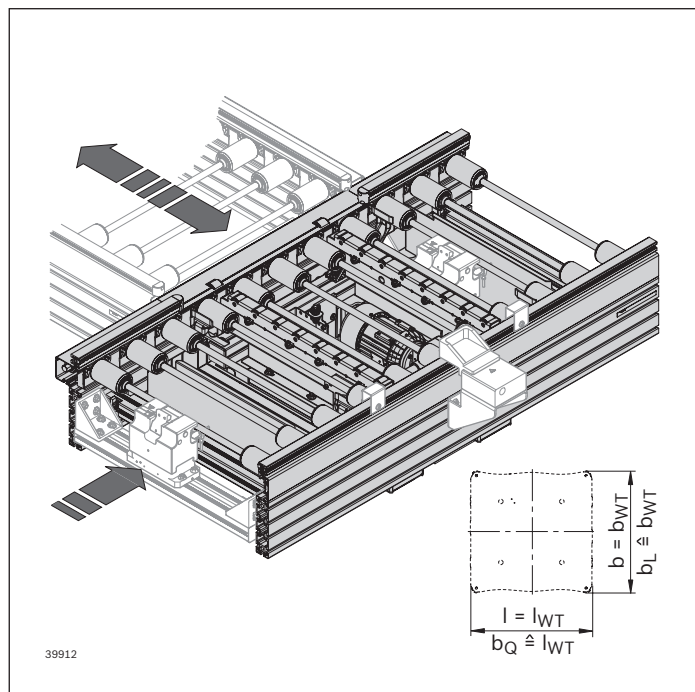

Lift transverse unit HQ 5/XH and HQ 5/H

Product description	Material number
HQ 5/XH	3 842 998 929
HQ 5/H	3 842 998 928
	$b_L = \dots$ mm
	$b_Q = \dots$ mm
	$p = \dots$ mm
	$l = \dots$ mm
	LG = ...
	BG = ...
	TR = ...
	AO = ...
	OFD = ...
	DSM = ...
	CT = ...
	GM = ...
	$v_N = \dots$ m/min, see page 13-9
	$U = \dots$ V, see page 13-8
	$f = \dots$ Hz, see page 13-8
	AT = ...

Lift transverse unit HQ 5/XH and HQ 5/H

b_L (mm)	b_Q (mm)	p (mm)	l (mm)	N	LG	BG	TR	AO	OFD	DSM	CT	GM	v_N (m/min)	AT
455	455	130	780 ... 4160	6; 7 ... 32	1; 2; 3	1; 2	1; 2	3; 4 ... 29	1; 2; 3	1; 2	0; 1	0; 1; 2	6; 9; 12	K; S
455	650	130	910 ... 4160	7; 8 ... 32	1; 2; 3	1; 2	1; 2	4; 5 ... 28	1; 2; 3	1; 2	0; 1	0; 1; 2	6; 9; 12	K; S
455	650	195	1170 ... 4095	6; 7 ... 21	1; 2; 3	1; 2	1; 2	3; 4 ... 18	1; 2; 3	1; 2	0; 1	0; 1; 2	6; 9; 12	K; S
650	650	130	910 ... 4160	7; 8 ... 32	1; 2; 3	1; 2	1; 2	4; 5 ... 28	1; 2; 3	1; 2	0; 1	0; 1; 2	6; 9; 12	K; S
650	650	195	1170 ... 4095	6; 7 ... 21	1; 2; 3	1; 2	1; 2	3; 4 ... 18	1; 2; 3	1; 2	0; 1	0; 1; 2	6; 9; 12	K; S
650	845	130	1170 ... 4160	9; 10 ... 32	1; 2; 3	1; 2	1; 2	5; 6 ... 27	1; 2; 3	1; 2	0; 1	0; 1; 2	6; 9; 12	K; S
650	845	195	1365 ... 4095	7; 8 ... 21	1; 2; 3	1; 2	1; 2	4; 5 ... 17	1; 2; 3	1; 2	0; 1	0; 1; 2	6; 9; 12	K; S
650	845	260	1560 ... 4160	6; 7 ... 16	1; 2; 3	1; 2	1; 2	3; 4 ... 13	1; 2; 3	1; 2	0; 1	0; 1; 2	6; 9; 12	K; S
845	845	130	1170 ... 4160	9; 10 ... 32	1; 2; 3	1; 2	1; 2	5; 6 ... 27	1; 2; 3	1; 2	0; 1	0; 1; 2	6; 9; 12	K; S
845	845	195	1365 ... 4095	7; 8 ... 21	1; 2; 3	1; 2	1; 2	4; 5 ... 17	1; 2; 3	1; 2	0; 1	0; 1; 2	6; 9; 12	K; S
845	845	260	1560 ... 4160	6; 7 ... 16	1; 2; 3	1; 2	1; 2	3; 4 ... 13	1; 2; 3	1; 2	0; 1	0; 1; 2	6; 9; 12	K; S
845	1040	130	1300 ... 4160	10; 11 ... 32	1; 2; 3	1; 2	1; 2	5; 6 ... 27	1; 2; 3	1; 2	0; 1	0; 1; 2	6; 9; 12	K; S
845	1040	195	1560 ... 4095	8; 9 ... 21	1; 2; 3	1; 2	1; 2	4; 5 ... 17	1; 2; 3	1; 2	0; 1	0; 1; 2	6; 9; 12	K; S
845	1040	260	1560 ... 4160	6; 7 ... 16	1; 2; 3	1; 2	1; 2	3; 4 ... 13	1; 2; 3	1; 2	0; 1	0; 1; 2	6; 9; 12	K; S
845	1040	325	1300 ... 3900	4; 5 ... 12	1; 2; 3	1; 2	1; 2	2; 3 ... 10	1; 2; 3	1; 2	0; 1	0; 1; 2	6; 9; 12	K; S

b_L = Track width (longitudinal conveyor)	TR = Roller material	GM = Gear motor
b_Q = Track width (transverse conveyor)	1: Steel; galvanized	0: without (interface SW27)
p = Roller spacing (pitch)	2: Steel; nitrocarburized	1: with gear motor SW27
l = Length graduated according to the roller dimensions ($l = p \times N$)	AO = Lift transverse unit installation location in section	2: without (interface to connection SEW, round shaft $\varnothing 20$)
N = Number of rollers, multiplier for length ($l = p \times N$), pricing factor in the price list	OFD = Direction of the outfeed	v_N = Nominal speed
LG = Lateral guide material	1: left	$U = 0, v_N > 0$: with gear, without motor
1: Steel	2: right;	$v_N = 0$: without motor and gear
2: Plastic;	3: to both sides	AT = Motor connection
3: Aluminum	DSM = King shaft installation on main section	K: with terminal box
BG = Bevel wheel material	1: left	S: with cable/plug
1: Plastic	2: right	
2: Sintered metal	CT = Protective case	
	0: without protective case	
	1: with protective case	

Description of further parameters, see page 0-3
Order examples, see page 6-9

Order examples for the king shaft installation and direction of the outfeed

Size shown

b = 650 x 650 mm

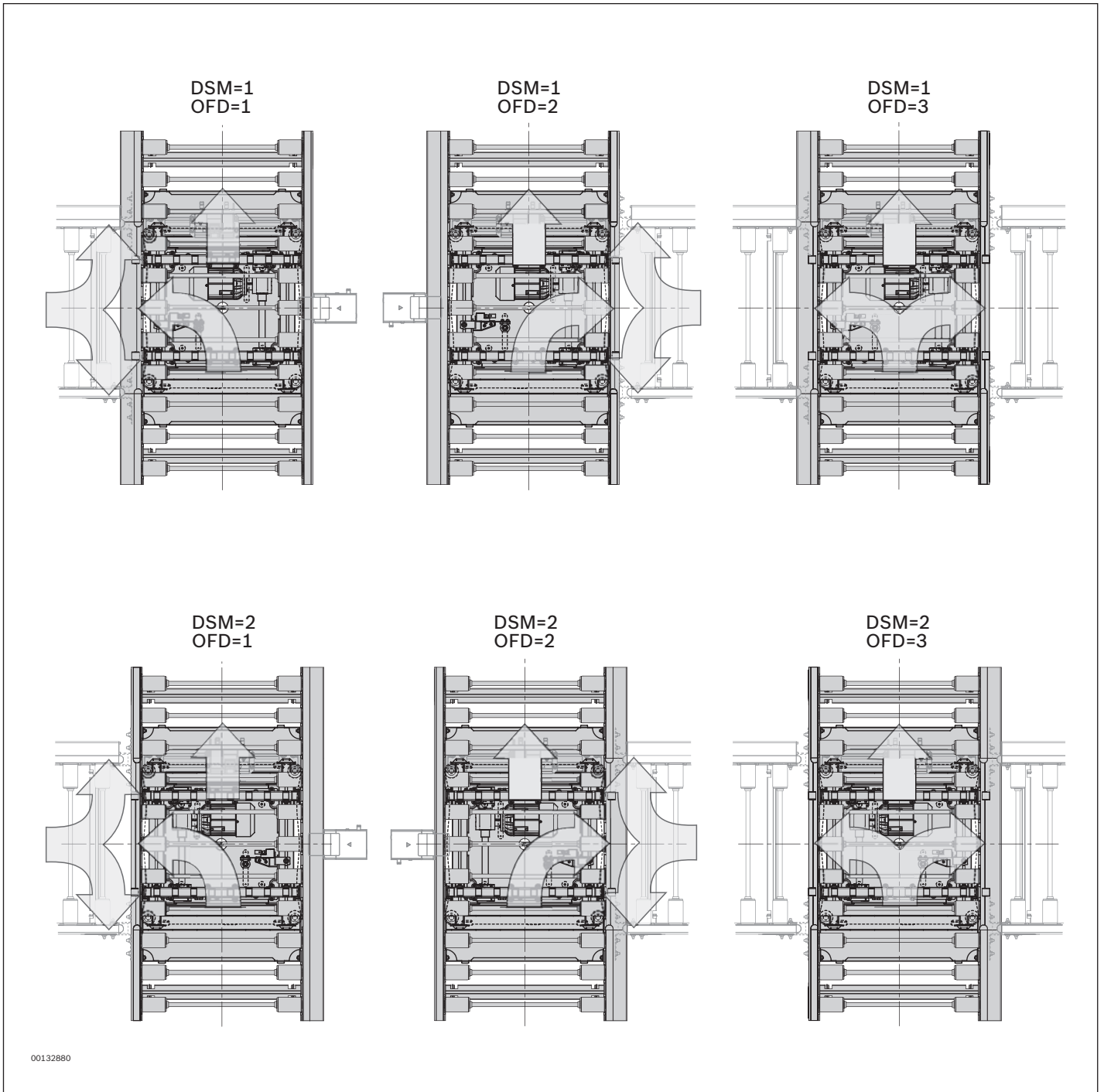

On request:

During infeeding in the main section, the VE 5/D-301 can be installed in the HQ as an alternative to the damper. In this case, the workpiece pallet is stopped in the center of the HQ and can then continue in any direction.

Dimensions

Lift transverse unit HQ 5

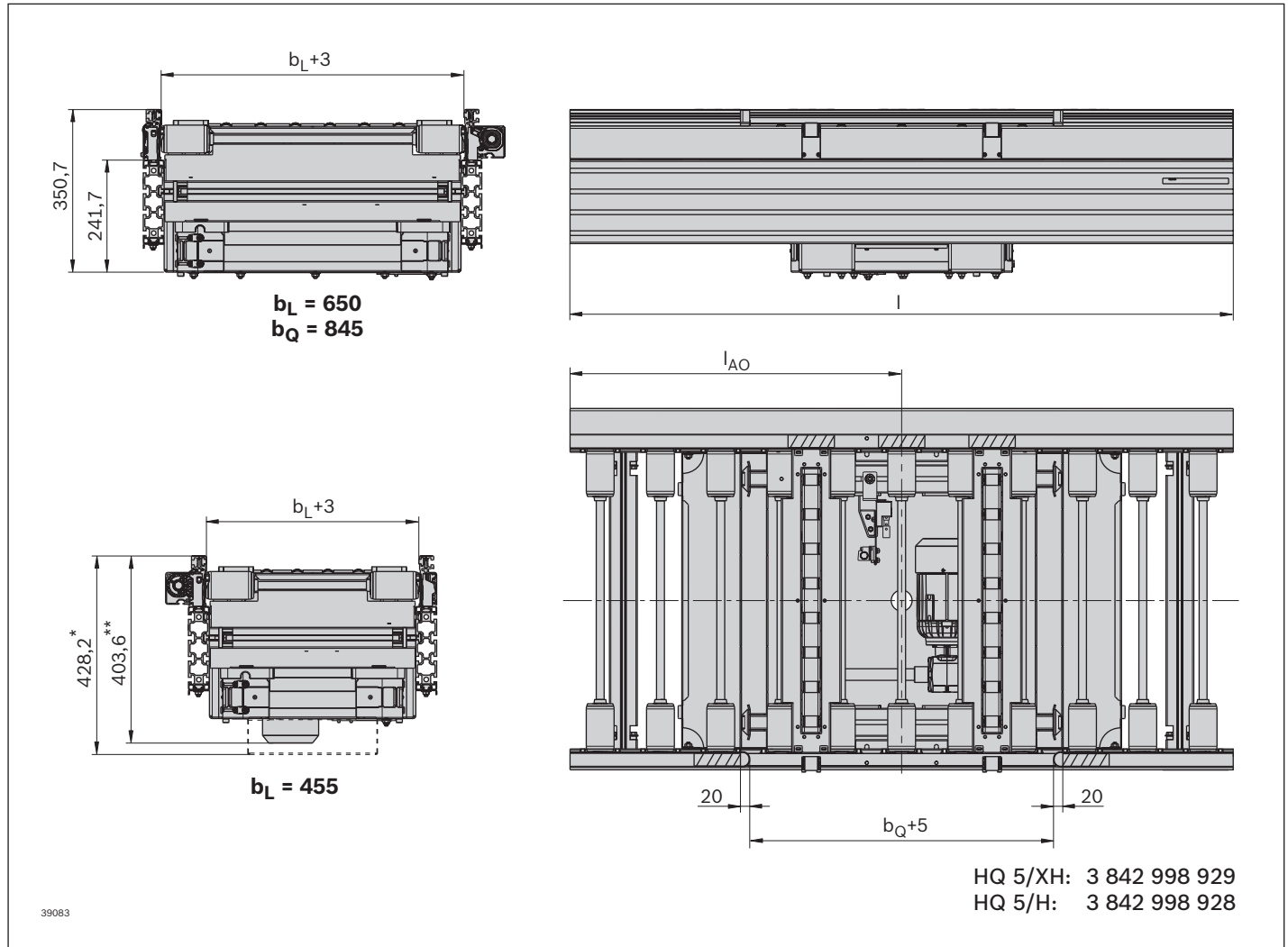

* with protective case

** without protective case

WT dimensions $b_L \times b_o$ and pitch p

AO is the roller that coincides with the center of the lift transverse unit (example: AO = 6, see page 6-12).

						For SEW gear motor or VE before HQ		For VE after HQ		For SEW gear motor and VE after HQ		
b_L (mm)	b_o (mm)	p (mm)	AO _{min}	AO _{max}	I_{min} (mm)	AO _{min} ¹⁾	$I_{min}^{1)}$ (mm)	AO _{max} ²⁾	$I_{min}^{2)}$ (mm)	AO _{min} ³⁾	AO _{max} ³⁾	$I_{min}^{3)}$ (mm)
455	650	130	4	(N+1) - AO _{min}	910	5	1040	N - AO _{min}	1040	5	N - AO _{min}	1170
650	650	130	4	(N+1) - AO _{min}	910	5	1040	N - AO _{min}	1040	5	N - AO _{min}	1170
650	845	130	5	(N+1) - AO _{min}	1170	6	1300	N - AO _{min}	1300	6	N - AO _{min}	1430
650	845	195	4	(N+1) - AO _{min}	1365	-	-	-	-	-	-	-
845	845	130	5	(N+1) - AO _{min}	1170	6	1300	N - AO _{min}	1300	6	N - AO _{min}	1430
845	845	195	4	(N+1) - AO _{min}	1365	-	-	-	-	-	-	-

6

AO is the space between two rollers in which the center of the lift transverse unit falls (example: AO = 5, see page 6-12).

						For SEW gear motor or VE before HQ		For VE after HQ		For SEW gear motor and VE after HQ		
b_L (mm)	b_o (mm)	p (mm)	AO _{min}	AO _{max}	I_{min} (mm)	AO _{min} ¹⁾	$I_{min}^{1)}$ (mm)	AO _{max} ²⁾	$I_{min}^{2)}$ (mm)	AO _{min} ³⁾	AO _{max} ³⁾	$I_{min}^{3)}$ (mm)
455	455	130	3	N - AO _{min}	780	4	910	N - AO _{min} -1	910	4	N - AO _{min} -1	1040
455	650	195	3	N - AO _{min}	1170	-	-	-	-	-	-	-
650	650	195	3	N - AO _{min}	1170	-	-	-	-	-	-	-
650	845	260	3	N - AO _{min}	1560	-	-	-	-	-	-	-
845	845	260	3	N - AO _{min}	1560	-	-	-	-	-	-	-
845	1040	130	5	N - AO _{min}	1300	-	-	-	-	-	-	-
845	1040	195	4	N - AO _{min}	1560	-	-	-	-	-	-	-
845	1040	325	2	N - AO _{min}	1300	3	1625	N - AO _{min} -1	1625	4	N - AO _{min} -1	1950

AO is the space between two rollers in which the center of the lift transverse unit falls (example: AO = 4, see page 6-13).

						For SEW gear motor or VE before HQ		For VE after HQ		For SEW gear motor and VE after HQ		
b_L (mm)	b_o (mm)	p (mm)	AO _{min}	AO _{max}	I_{min} (mm)	AO _{min} ¹⁾	$I_{min}^{1)}$ (mm)	AO _{max} ²⁾	$I_{min}^{2)}$ (mm)	AO _{min} ³⁾	AO _{max} ³⁾	$I_{min}^{3)}$ (mm)
845	1040	260	3	N - AO _{min}	1560	-	-	N - AO _{min} -1	1820	3	N - AO _{min} -1	1950

Notice: The minimum length I_{min} specified in the table does not always allow for the installation of an SEW gear motor or a stop gate before or after HQ 5.

In these cases, the minimum permitted section length I_{min} is increased to allow for installation.

The installation location AO_{min} is increased and the installation location AO_{max} is reduced:

- 1) When using an SEW gear motor or when installing a stop gate before HQ 5
- 2) When installing a stop gate after HQ 5
- 3) When using an SEW gear motor and installing a stop gate after HQ 5

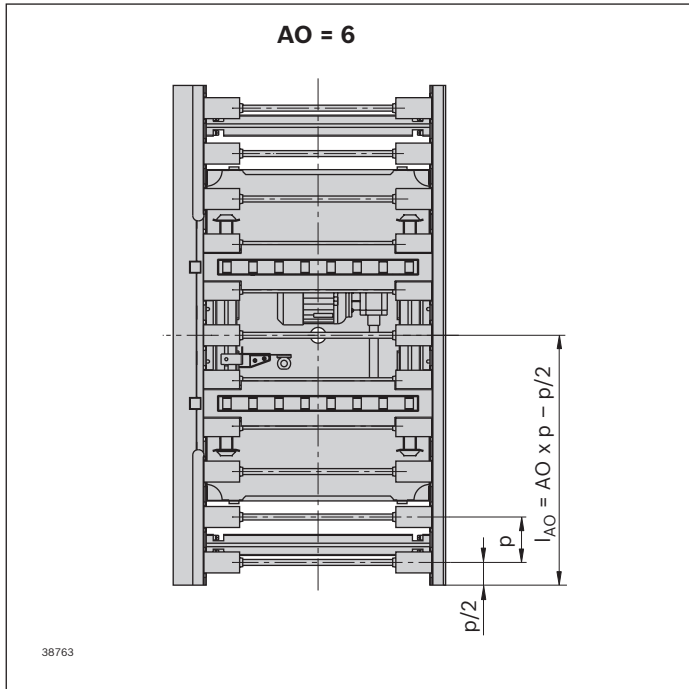

Example AO = 6

For possible mounting positions AO, see table on page 6-11

Permissible position I_{AO} (mm) after start of section:

$$I_{AO} = AO \times p - p/2$$

Example for $p = 130$ mm and $DP = 6$:

$$I_{AO} = 6 \times 130 \text{ mm} - 65 \text{ mm} = 715 \text{ mm}$$

Description of further parameters, see page 0-3

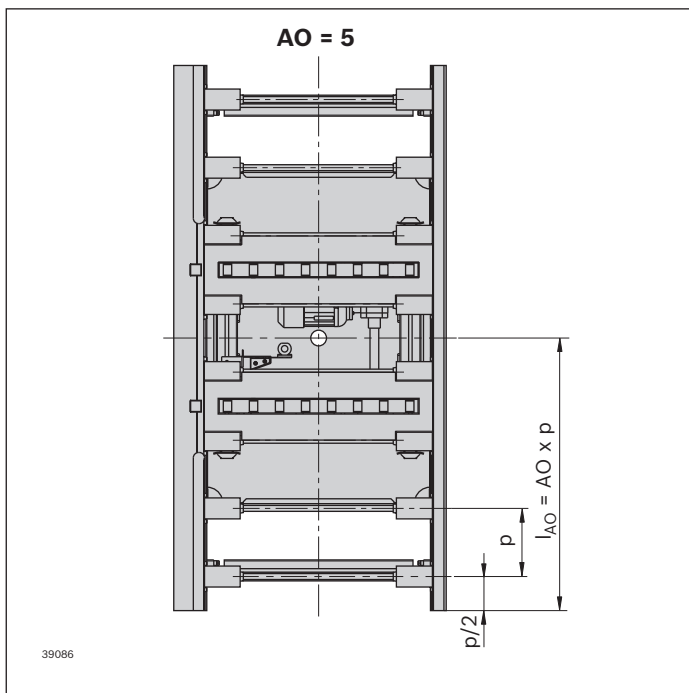

Example: AO = 5

For possible mounting positions AO, see table on page 6-11

Permissible position I_{AO} (mm) after start of section:

$$I_{AO} = AO \times p$$

Example for $p = 195$ mm and $DP = 5$:

$$I_{AO} = 5 \times 195 \text{ mm} = 975 \text{ mm}$$

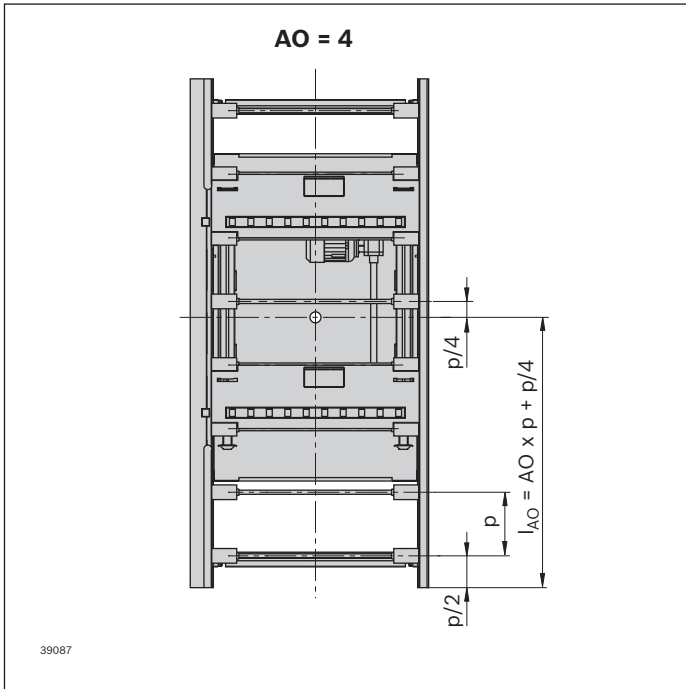

Example: AO = 4

For possible mounting positions AO, see table on page 6-11

Permissible position l_{AO} (mm) after start of section:

$$l_{AO} = AO \times p + p/4$$

Example for $p = 260$ mm and $DP = 4$:

$$l_{AO} = 4 \times 260 \text{ mm} + 65 \text{ mm} = 1105 \text{ mm}$$

Circuit diagram

Lift transverse unit HQ 5

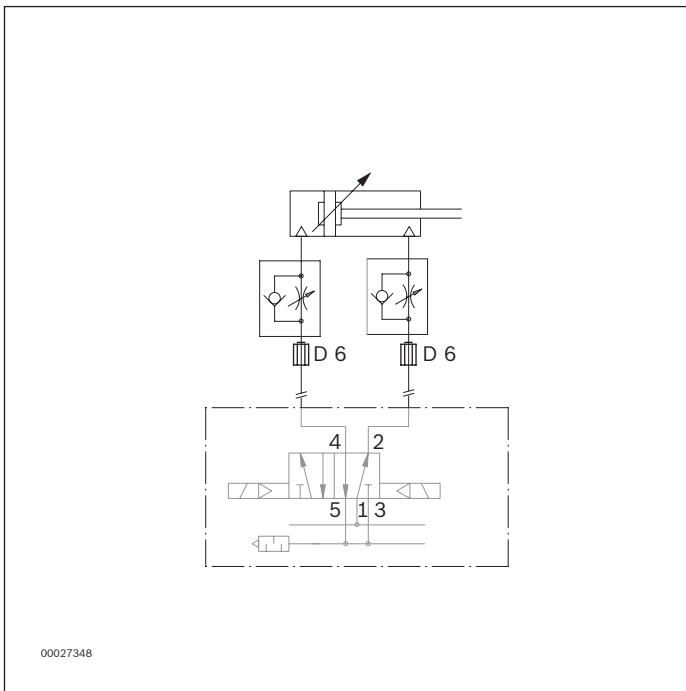

Damper DA 5/200, DA 5/1000



Use

- ▶ Damped stopping of an accumulating workpiece pallet during infeeding

Version

- ▶ Continuously adjustable damping (DA 5/200, DA 5/1000 self-adjusting)
- ▶ See table for workpiece pallet loads
- ▶ The damper is extended pneumatically into the damping position (infeeding of the WT to the main section) and is pushed into the end position by the infeeding workpiece pallet. A WT can only move onto the main section if the damper is in the end position.
- ▶ Compressed air connection: 5 ... 6 bar

Notice: If the damper is extended, it moves into the main section and cannot be retracted pneumatically! The damper can only be retracted by infeeding a workpiece pallet. Collision hazard if there are overhanging carrying plates.

Scope of delivery

- ▶ Incl. fastening material for assembly on the conveyor section; push in air connection \varnothing 6 mm

Recommended accessories

- ▶ Cover for the lateral guide, see page 6-22f

Condition on delivery

- ▶ Not assembled

Ordering information

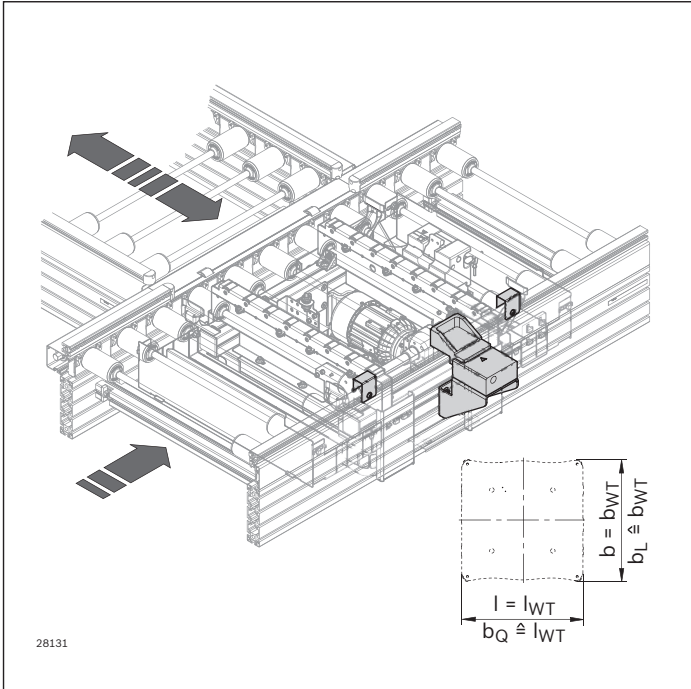

28131

Damper DA 5/200

	Material number
Set	3 842 545 128

Permissible impact force per WT

m_{WT} (kg)	$v_N^{1)}$ (m/min)
max. 280	2 ... 9
max. 240	2 ... 12
max. 140	2 ... 18

¹⁾ Conveyor speed

Damper DA 5/1000

	Material number
Set	3 842 545 130

Permissible impact force per WT

m_{WT} (kg)	$v_N^{1)}$ (m/min)
min. 50 max. 1100	2 ... 9
min. 50 max. 1000	2 ... 12
min. 50 max. 800	2 ... 18

¹⁾ Conveyor speed

Dimensions

DA 5/200

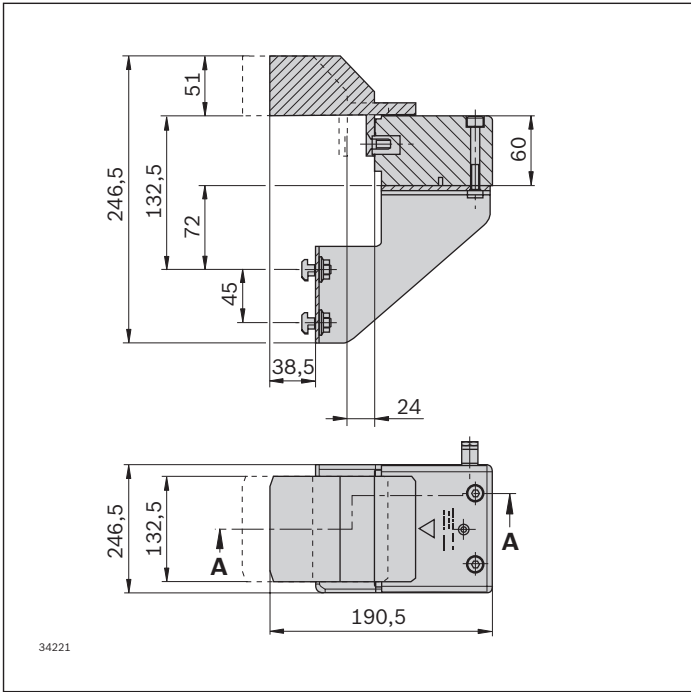

34221

Dimensions

DA 5/1000

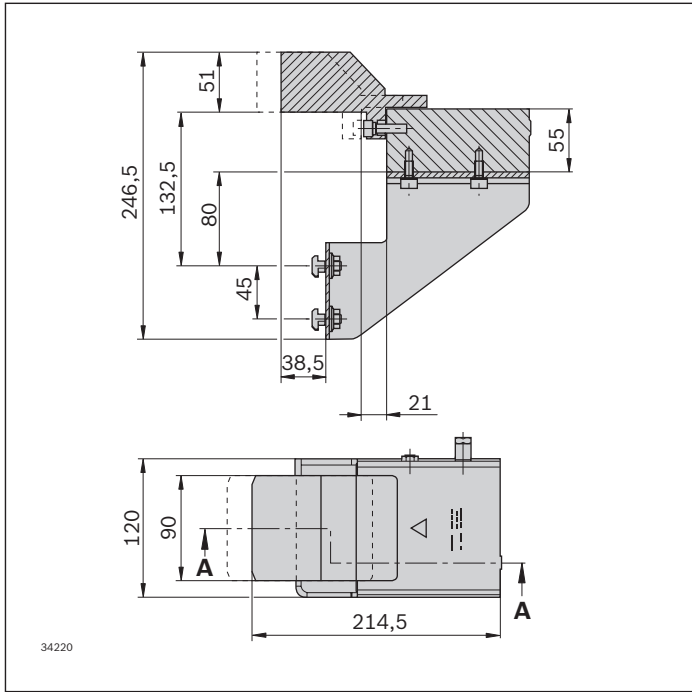

34220

Connection kit for connecting the transverse section

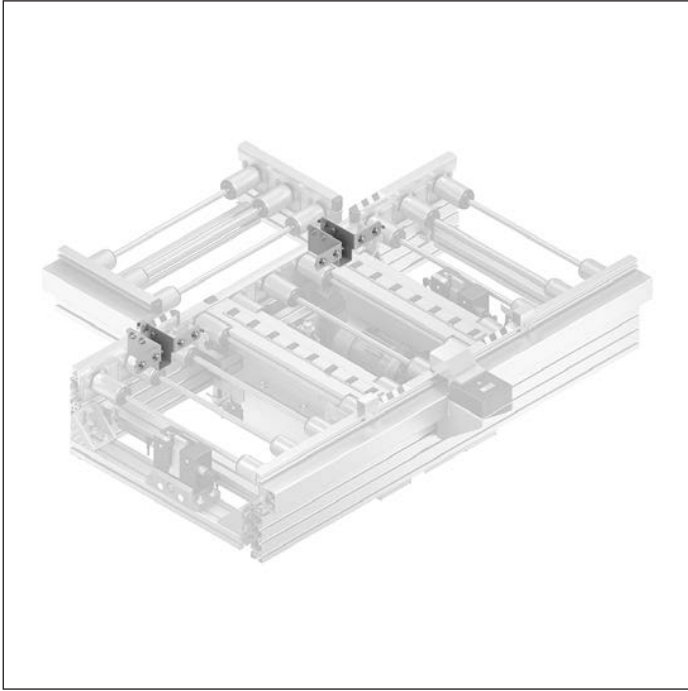

Use

- ▶ For connecting the transverse section, independent of the drive side of the main section. If a circuit only consists of lift transverse units, the transverse sections are connected directly to the longitudinal section.

Version

- ▶ Support brackets made from galvanized steel incl. covers for the open profile ends of the transverse section

Scope of delivery

- ▶ Connection kit for connecting the transverse section:
2x support brackets incl. fastening material for assembly
- ▶ Guide kit:
2x guide aids incl. fastening material for assembly

Condition on delivery

- ▶ Not assembled

Ordering information

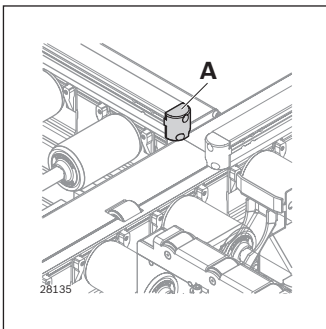
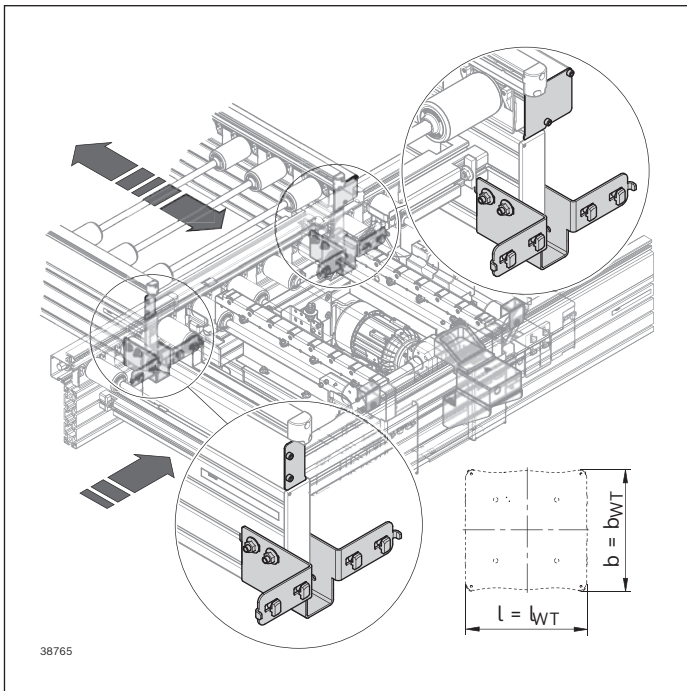

Connection kit for connecting the transverse section

		Material number
ST 5/XH, ST 5/H	Set	3 842 549 782
ST 5/OC DD = 2 ¹⁾	Set	3 842 549 783
ST 5/OC DD = 1 ¹⁾	Set	3 842 549 784

- ¹⁾ DD = Drive
 1: on one side
 2: on two sides

Guide kit

- ▶ The guide kit (**A**) is part of the connection bridge (see page 6-18).
- ▶ For the connection of a standard section, the guide kit (**A**) must be ordered separately.

		Material number
A	Set	3 842 545 975

Connection bridge

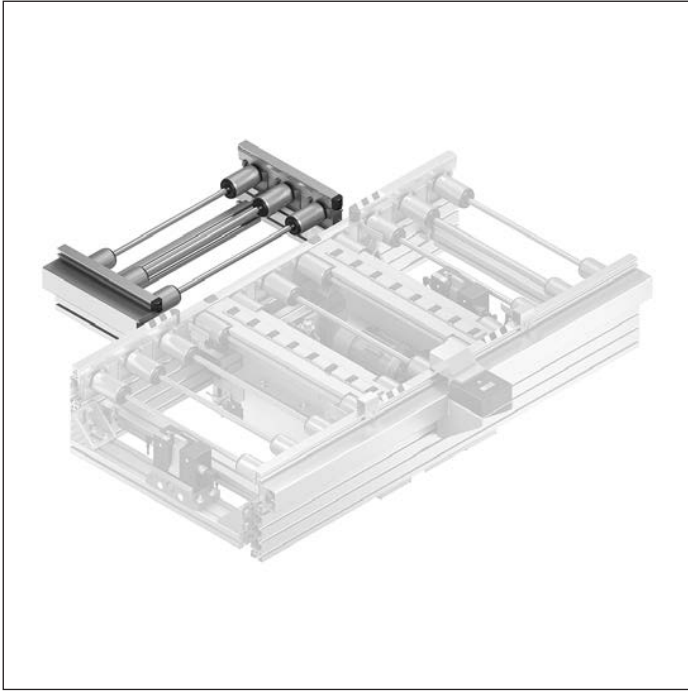

Use

- ▶ The connection bridge is used for length adjustment when parallel transverse sections are used with lift transverse units and curves/diverters/junctions

Version

- ▶ Support profile made of anodized aluminum
- ▶ Permissible section load:
 - ST 5/XH: 380 kg/m
 - ST 5/H: 200 kg/m
- ▶ Lateral guide profile made of steel, plastic, or aluminum in an anodized aluminum support
- ▶ Driven via king shaft with bevel wheels made of plastic or sintered metal

Notice: In contrast to a conveyor unit or a drive module, curves, diverters and junctions have a different roller distance. The connection bridge is not a conveyor unit with a standard roller distance.

Condition on delivery

- ▶ Ready-to-install

Required accessories

- ▶ Connection kit for connecting the transverse section, see page 6-16

Material

- ▶ Roller: Steel, galvanized

Ordering information

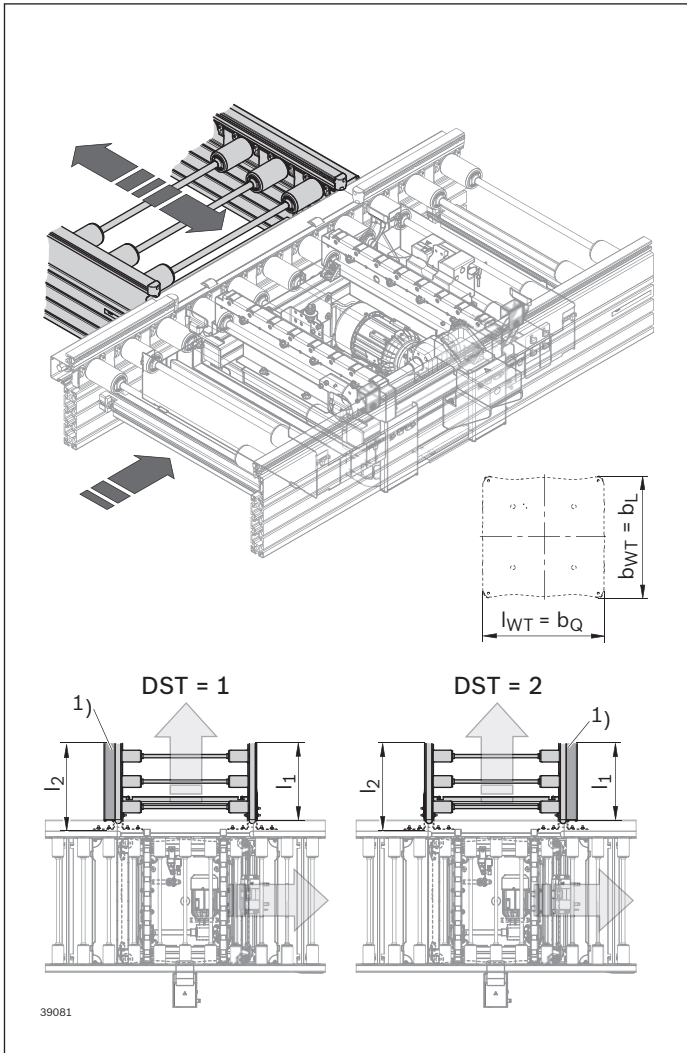

Connection bridge

Product description	Material number
ST 5/XH	3 842 998 605
ST 5/H	3 842 998 604
	$b_L = \dots$ mm
	$b_Q = \dots$ m
	LG = ...
	BG = ...
	DST = ...
	TR = ...
	SC = ...

b_L (mm)	b_Q (mm)	l_1 (mm)	l_2 (mm)
455	455	328.5	382.5
455	650	328.5	382.5
650	650	361	415
650	650	361	415
845	845	393.5	447
845	1040	393.5	447

¹⁾ Drive side

Connection bridge

b_L (mm)	b_Q (mm)	LG	BG	DST	TR	SC
455	455	1; 2; 3	1; 2	1; 2	1; 2	1; 2
455; 650	650	1; 2; 3	1; 2	1; 2	1; 2	1; 2
650; 845	845	1; 2; 3	1; 2	1; 2	1; 2	1; 2
845	1040	1; 2; 3	1; 2	1; 2	1; 2	1; 2

b_L = Width of workpiece pallet
 b_Q = Width of transverse section
 LG = Lateral guide material
 1: Steel; 2: Plastic;
 3: Aluminum

BG = Bevel wheel material
 1: Plastic
 2: Sintered metal
 DST = King shaft installation on secondary section
 1: left
 2: right

TR = Roller material
 1: Steel; zinc-plated
 2: Steel; nitrocarburized
 SC = Protective covers
 1: without protective covers
 2: with protective covers

Description of further parameters, see page 0-3

Order examples, see page 6-9

Protective covers for lift transverse unit HQ 5



Use

- ▶ The protective covers are provided in working areas to increase safety.
- ▶ Mobile protective covers (**A, B**) are assembled to HQ 5, fixed protective covers (**C**) are clipped between the rollers using spring elements. The user must make the openings in the protective covers, see assembly instructions.

Notice: Do not walk on the protective covers.
Slots for add-on parts must be made by the customer; for details, see assembly instructions.

Versions

- ▶ Protective covers for various widths and roller spacings

Material

- ▶ Steel, galvanized

Ordering information

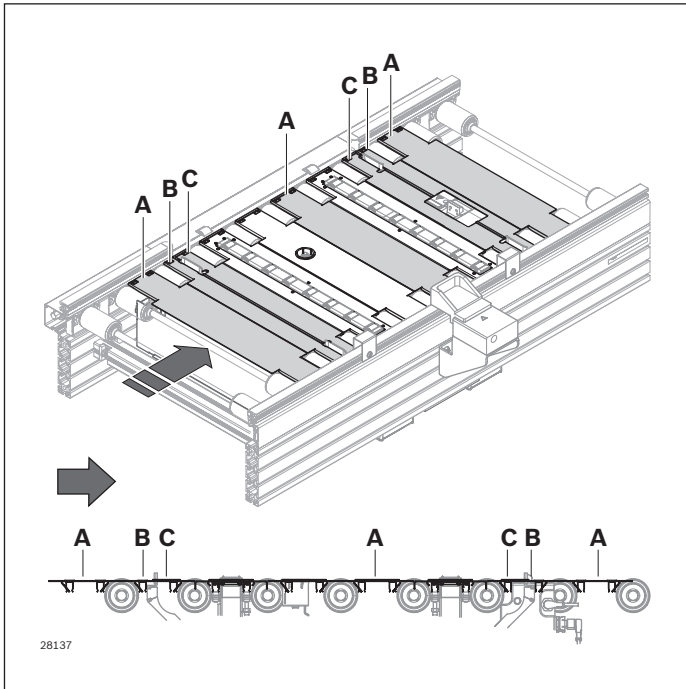

Required protective covers for HQ 5

b_L (mm)	b_O (mm)	p (mm)	n	Material number A	n	Material number B	C
455	455	130	8x	3 842 545 404	1x	3 842 545 966	2x Pre-assembled in the scope of delivery
455	650	130	9x	3 842 545 404	1x	3 842 545 966	
455	650	195	6x	3 842 545 609	1x	3 842 545 966	
650	650	130	9x	3 842 545 405	1x	3 842 545 966	
650	650	195	6x	3 842 545 360	1x	3 842 545 966	
650	845	130	11x	3 842 545 405	1x	3 842 545 966	
650	845	195	7x	3 842 545 360	1x	3 842 545 966	
650	845	260	5x	3 842 545 612	1x	3 842 545 966	
845	845	130	11x	3 842 545 361	1x	3 842 545 966	
845	845	195	7x	3 842 545 362	1x	3 842 545 966	
845	845	260	5x	3 842 545 363	1x	3 842 545 966	
845	1040	130	12x	3 842 545 361	1x	3 842 545 966	
845	1040	195	8x	3 842 545 362	1x	3 842 545 966	
845	1040	260	6x	3 842 545 363	1x	3 842 545 966	
845	1040	325	4x	3 842 545 403	1x	3 842 545 966	

- b_L = Track width (longitudinal conveyor)
- b_O = Track width (transverse conveyor)
- p = Roller spacing (pitch)
- n = Required quantity

Cover for lateral guide of lift transverse unit HQ 5

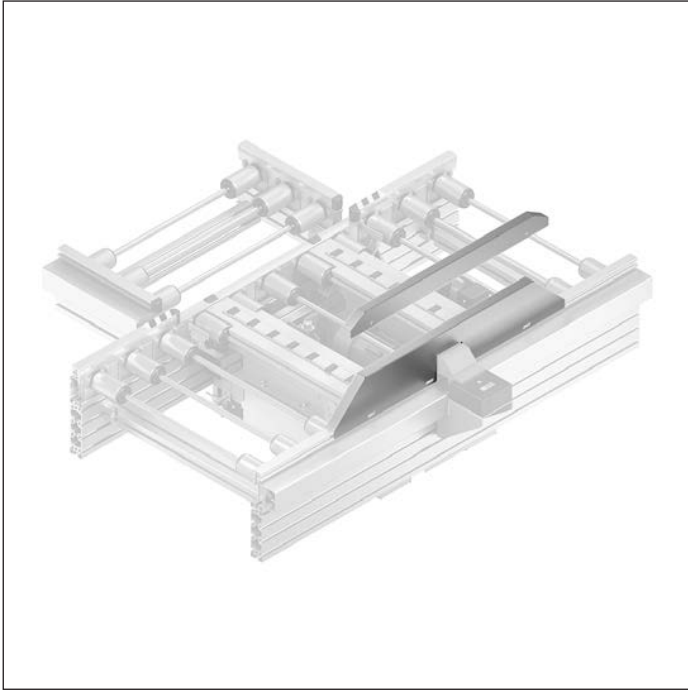

Use

- ▶ Covers must be provided for the lateral guide in the vicinity of the HQ 5 lift transverse unit (see page 6-4) to increase safety.

Notice: Do not walk on the protective covers.

Versions

- ▶ Covers with **(A)** a slot for dampers DA 5/...
- ▶ Covers without **(B)** a slot for dampers DA 5/...

Required accessories

- ▶ T-bolt, see page 6-23
- ▶ Flange nut, see page 6-23

Material

- ▶ Steel, galvanized

Ordering information

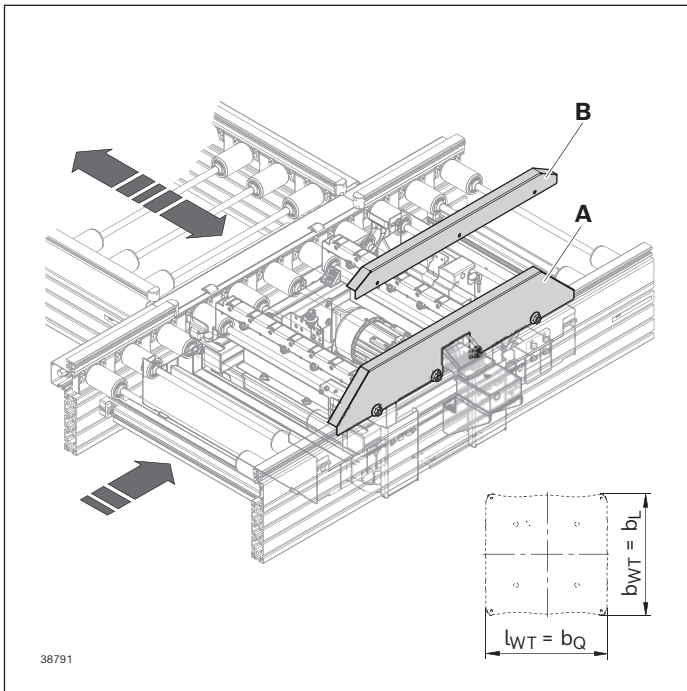

Covers for lateral guide of HQ 5

	b_Q (mm)	Material number
A	455	3 842 552 658
	650	3 842 552 659
	845	3 842 552 660
	1040	3 842 552 661
B	455	3 842 552 662
	650	3 842 552 663
	845	3 842 552 664
	1040	3 842 552 665

b_Q = Track width (transverse conveyor)

Required fastening materials:

		Material number
Flange nut	100	3 842 345 081
T-bolt	100	3 842 528 718

Description of the T-bolt and flange nut, see page 7-10

6-24 **TS 5 5.0** | Transverse conveyor
Cover for lateral guide of lift transverse unit HQ 5

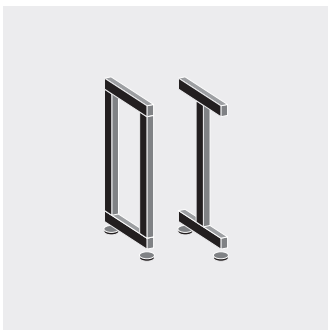

Leg sets

Design 7-2

Leg set SZ 5 7-4

Leg set SZ 5/U 7-6

Leg set SZ 5/OC 7-8

Foundation brackets, dowels 7-10

7

Design

Leg sets

Leg sets support the conveyor section. We recommend providing a separate leg set for every module (conveyor unit, curve, diverter, junction) in order to compensate for height tolerances at the transitions.

A max. leg distance of 2000 mm must be maintained per workpiece pallet.

The engagement depth of the leveling feet must be at least 30 mm for all leg sets.

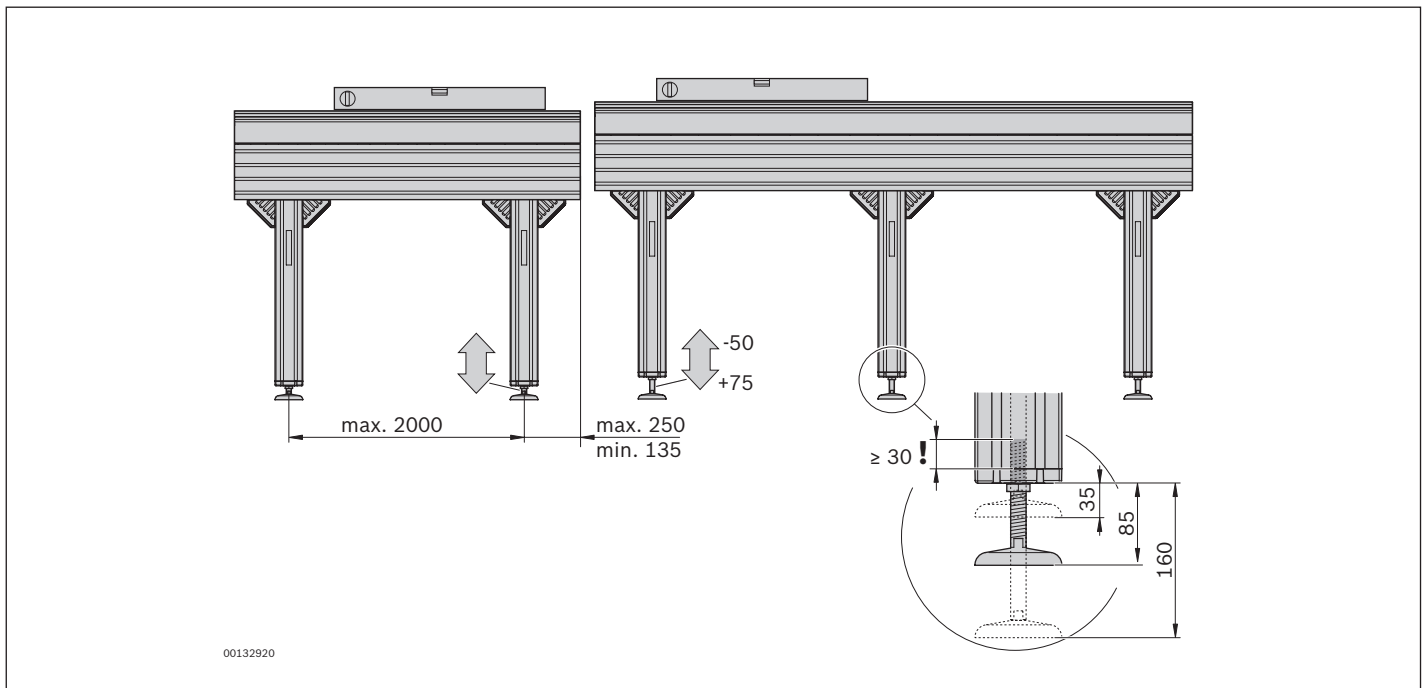

Since curves, diverters and junctions are only supported by 2 legs, the secondary section must be immediately supported after the transition, see Figures.

Recommended accessories

Leg sets can be anchored to the floor using foundation brackets 3 842 146 848 and dowels 3 842 526 560, see page 7-10

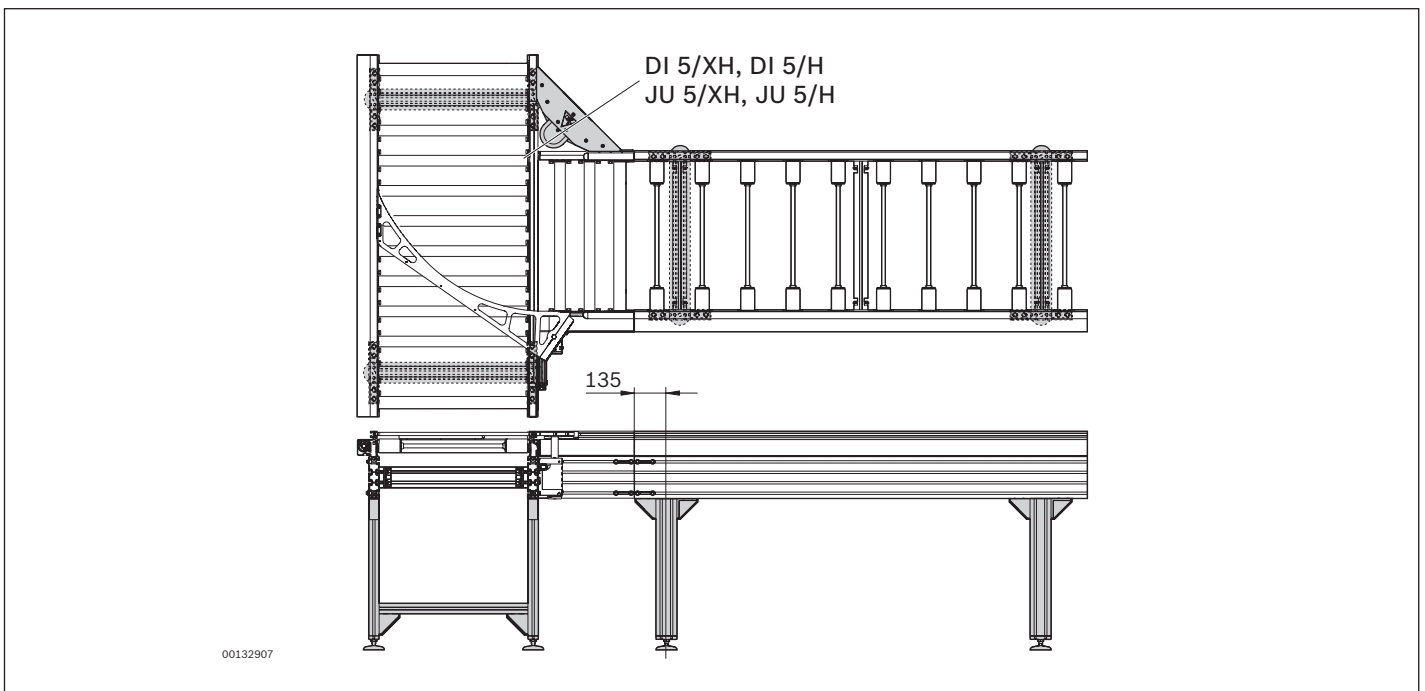
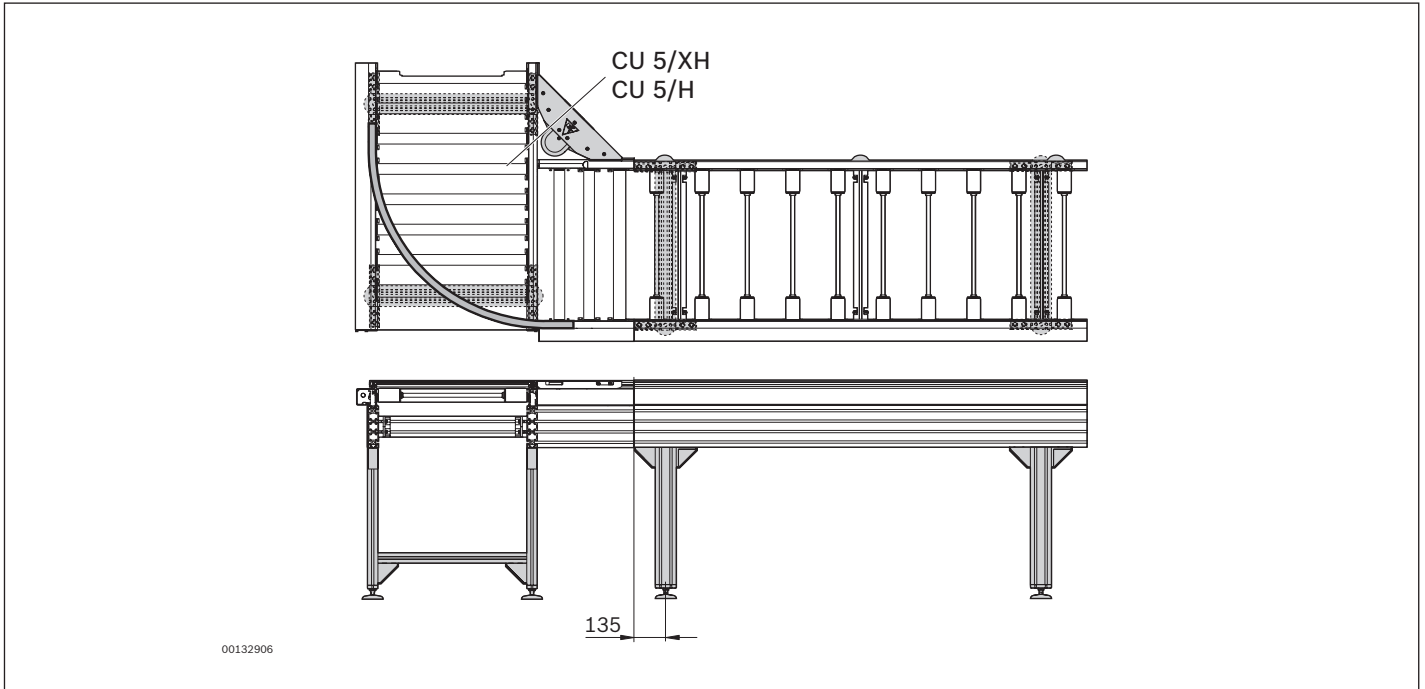

Leg set SZ 5

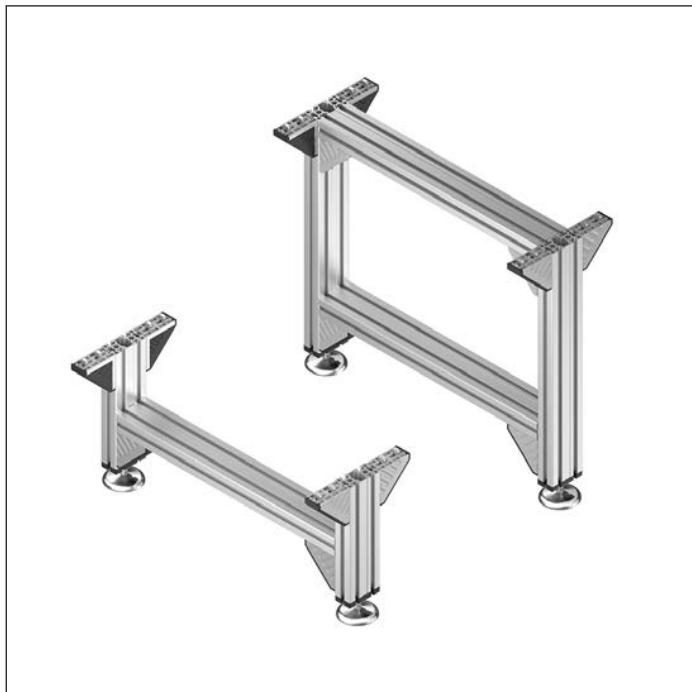

Use

- ▶ Leg set for general applications

Version

- ▶ Extruded aluminum profiles
- ▶ Height-adjustable bases
- ▶ Suitable for the construction of high-load conveyor sections in conjunction with the conveyor units ST 5/...
- ▶ Lowest possible transport level (with lowest possible foot setting of 35 mm):
 - ST 5/XH = 425.5 mm
 - ST 5/H = 335.5 mm

Notice: For transportation heights >1000 mm, we recommend that users compensate for horizontal braking forces with diagonal bracing struts, see MGE catalog.

Scope of delivery

- ▶ Incl. height-adjustable bases, incl. fastening material to mount the leg set onto a conveyor unit, drive unit, curve, diverter or junction.

Condition on delivery

- ▶ Assembled (MT = 1)
- ▶ Not assembled (MT = 0)

Recommended accessories

Bracket cover caps

		Material number
45x90, black ESD	100	3 842 548 865
90x90, black ESD	20	3 842 548 869

Ordering information

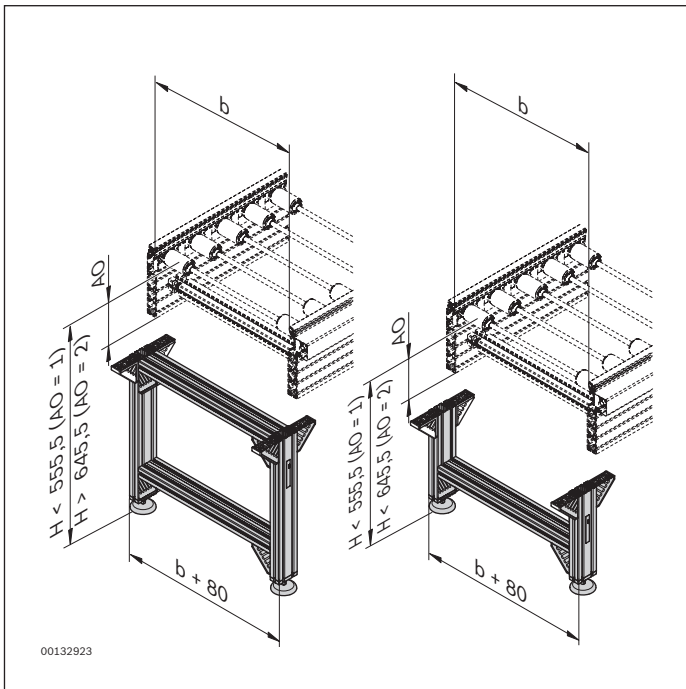

00132923

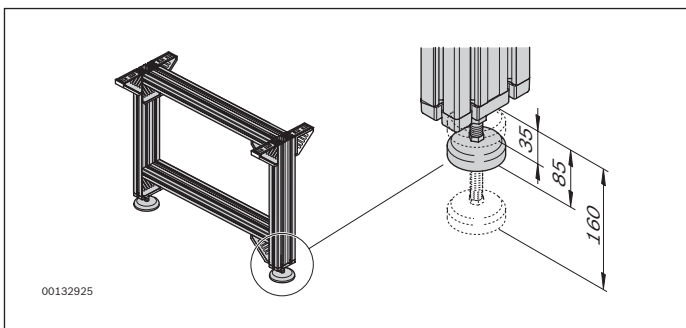

00132925

Leg set SZ 5

AO	b (mm)	H (mm)	MT	Material number
1	455; 650; 845; 1040	385.5 ... 2000	0; 1	3 842 996 330
2	455; 650; 845; 1040	475.5 ... 2000	0; 1	AO = ... b = ... mm H = ... mm MT = ...

AO = Installation location

1: ... 5/H

2: ... 5/XH

b = Track width

H = Transportation height

MT = Condition on delivery

0: not assembled

1: assembled

Leg set SZ 5/U

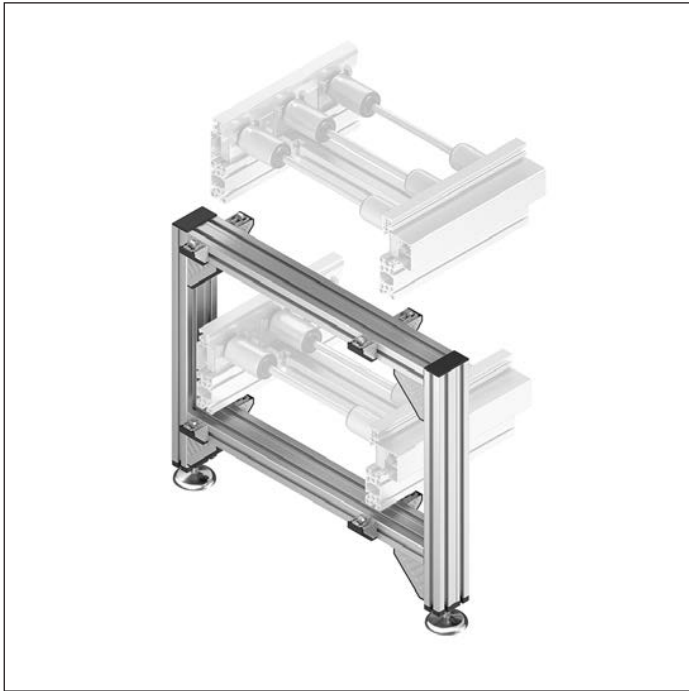

Use

- ▶ Leg set for multi-level sections

Version

- ▶ Extruded aluminum profiles
- ▶ Height-adjustable bases
- ▶ Suitable for the construction of high-load conveyor sections in conjunction with the conveyor units ST 5/...

Notice: For transportation heights >1000 mm, we recommend that users compensate for horizontal braking forces with diagonal bracing struts, see MGE catalog.

Scope of delivery

- ▶ Incl. height-adjustable bases, incl. fastening material to mount the leg set onto a conveyor unit, drive unit, curve, diverter or junction.

Condition on delivery

- ▶ Assembled (MT = 1)
- ▶ Not assembled (MT = 0)

Recommended accessories

Bracket cover caps

		Material number
45x45, black ESD	100	3 842 548 863
90x90, black ESD	20	3 842 548 869

Ordering information

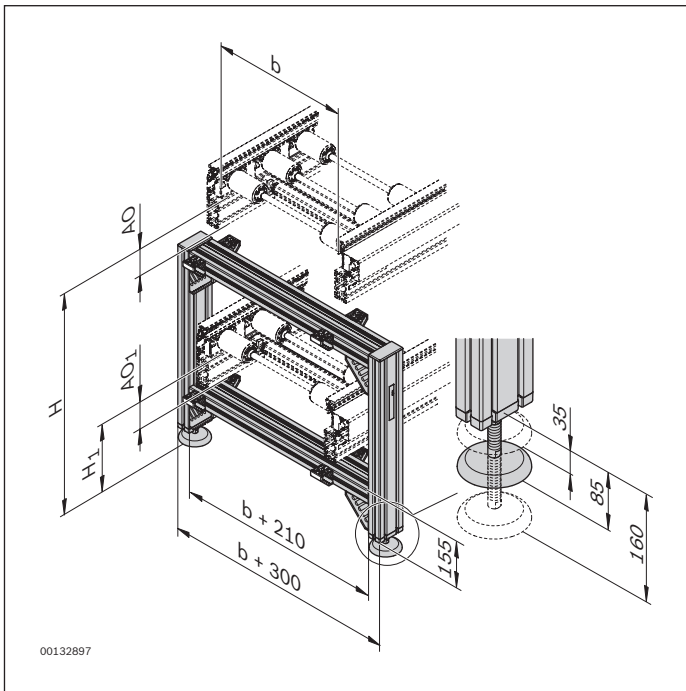

00132897

Leg set SZ 5/U

AO	b (mm)	H (mm)	AO ₁	H ₁ (mm)	MT	Material number
1	455; 650; 845; 1040	719.5 ... 2000	1	385.5 ... H-334	0; 1	3 842 996 331
			2	475.5 ... H-334		
2	455; 650; 845; 1040	899.5 ... 2000	1	385.5 ... H-424	0; 1	b = ... mm H = ... mm AO ₁ = ... H ₁ = ... mm MT = ...
			2	475.5 ... H-424		

AO = Installation location AO₁ = Installation location lower section b = Track width MT = Condition on delivery
 1: ... 5/H 1: ST 5/H H = Transportation height 0: not assembled
 2: ... 5/XH 2: ST 5/XH H1 = Transportation height lower section 1: assembled

Leg set SZ 5/OC



Use

- ▶ Leg set for Open Center sections

Version

- ▶ Extruded aluminum profiles
- ▶ Height-adjustable bases
- ▶ Suitable for the construction of high-load conveyor sections in conjunction with the conveyor units ST 5/OC...
- ▶ Lowest possible transport level (with lowest possible foot setting of 35 mm): 335.5 mm

Notice: For transportation heights >1000 mm, we recommend that users compensate for horizontal braking forces with diagonal bracing struts, see MGE catalog.

Scope of delivery

- ▶ Incl. height-adjustable bases, incl. fastening material to mount the leg set onto a conveyor unit, drive unit, curve, diverter or junction.

Condition on delivery

- ▶ Assembled (MT = 1)
- ▶ Not assembled (MT = 0)

Recommended accessories

Cover caps for brackets

		Material number
45x90, black ESD	100	3 842 548 865
90x90, black ESD	20	3 842 548 869

Ordering information

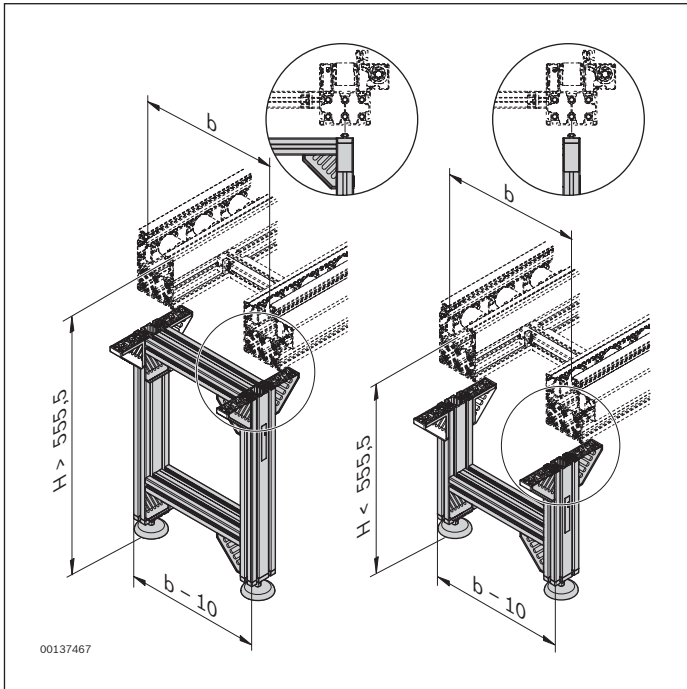

Leg set SZ 5/OC

	b (mm)	H (mm)	MT	Material number
455; 650; 845; 1040	385.5 ... 2000	0; 1		3 842 996 332
				b = ... mm
				H = ... mm
				MT = ...

- b = Track width
- H = Transportation height
- MT = Condition on delivery
- 0: not assembled
- 1: assembled

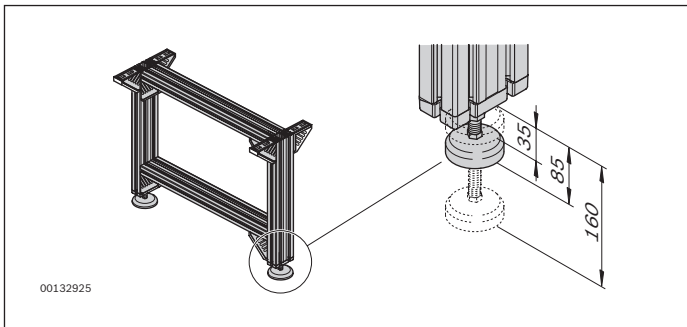

Foundation brackets, dowels

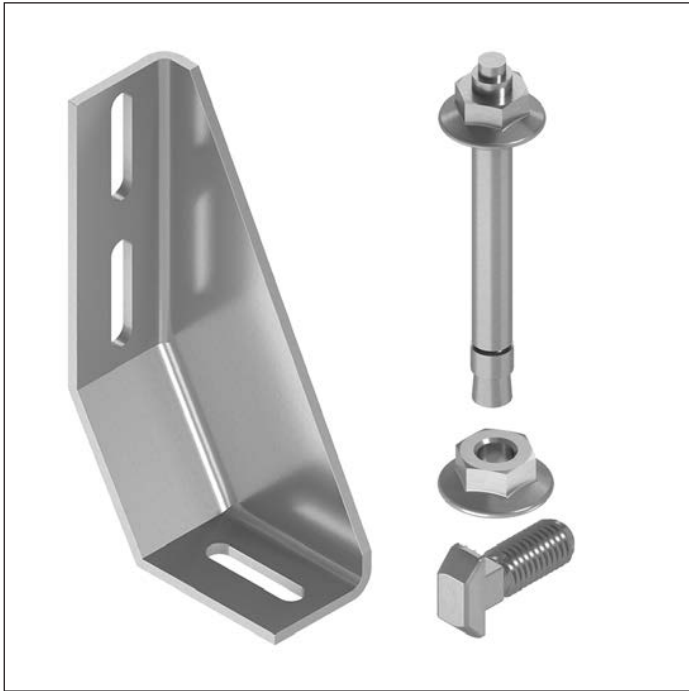

Use

- Frames are fastened to the floor with the foundation bracket. The hole for the dowel can be bored without removing the foundation bracket.

Material

- Foundation bracket: Sheet steel, galvanized and transparent chrome-plated

Ordering information

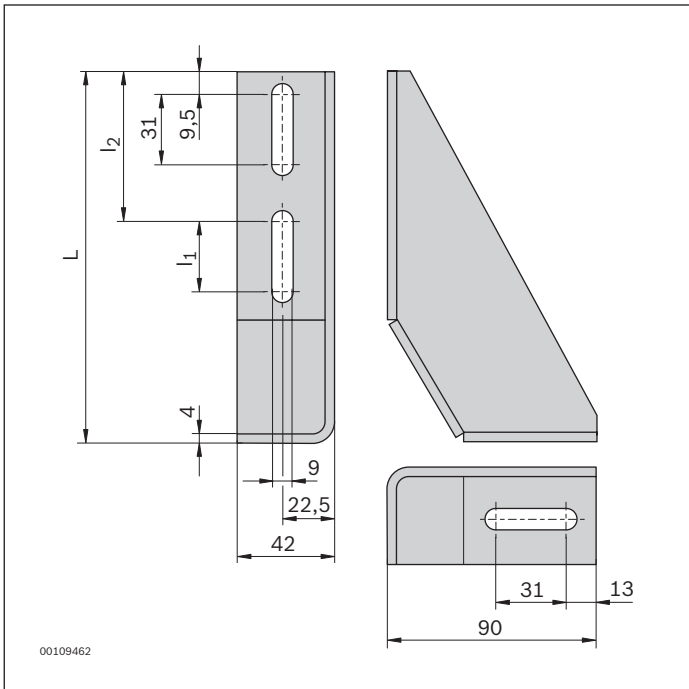

Product description	L (mm)	l ₁ (mm)	l ₂ (mm)		Material number
Foundation bracket	160	31	91	20	3 842 146 815
	210	91	54.5	20	3 842 146 848

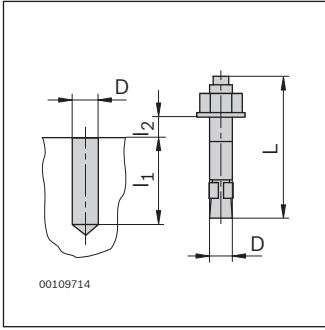

Product description	D (mm)	L (mm)	l ₁ (mm)	l _{2max} (mm)	 Material number
Dowel	8	80	65	15	100 3 842 526 560

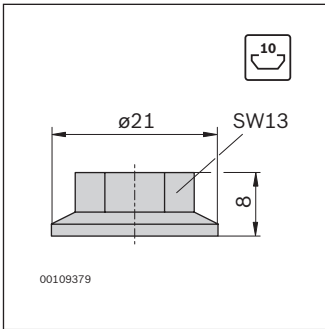

Product description	 Material number
Flange nut	100 3 842 345 081

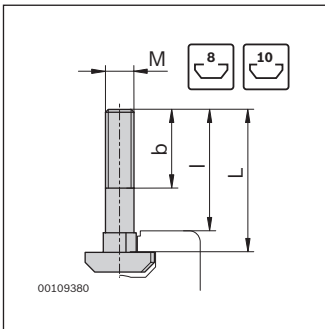

Product description	M	b (mm)	l (mm)	 Material number
T-bolt	M8x25	19	19	100 3 842 528 718
	M8x20	14	14	100 3 842 528 715

7-12 **TS 5 5.0** | Leg sets
Foundation brackets, dowels

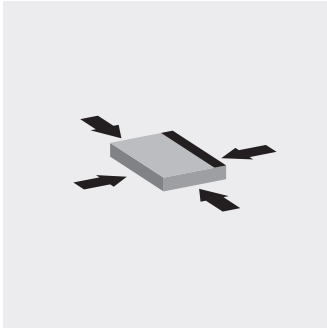

Positioning and orientation

Design	8-2
Positioning unit PE 5	8-3
Positioning unit PE 5/T	8-6
Positioning unit PE 5/L	8-9
Positioning unit PE 5/LT	8-12
Positioning unit PE 5/OC	8-15
Positioning unit PE 5/OC-T	8-18
Assembly kit for positioning unit PE 5 and PE 5/T	8-21
Protective sleeves for PE 5, PE 5/T, PE 5/L and PE 5/LT	8-22
Cover of lateral guide for positioning units	8-24
Protective covers for PE 5/OC and PE 5/OC-T	8-25

Design

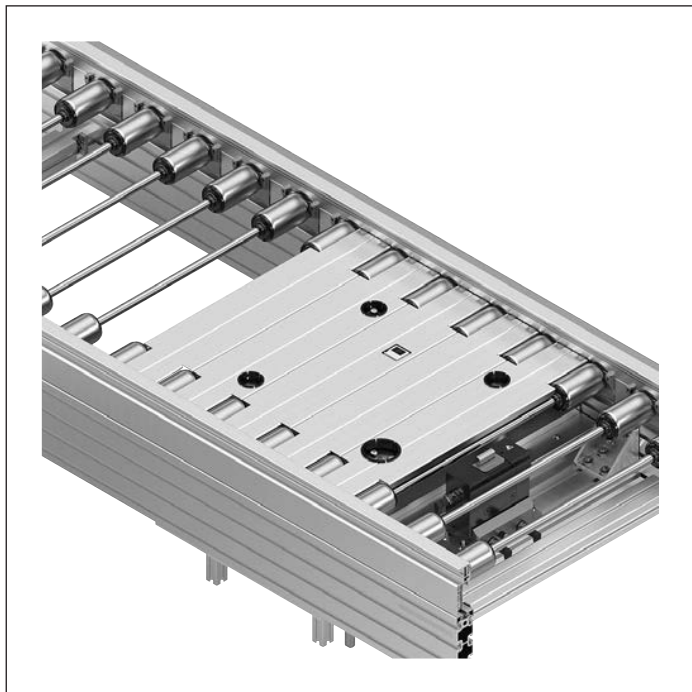

In order to process and maintain manufacturing tolerances, workpiece pallets must be stopped and positioned in the processing station.

In doing so, the workpiece pallets can be exactly positioned by up to ± 0.3 mm and the system can absorb vertical process forces of up to 4000 N.

Applications:

- ▶ For exact positioning and to lift the workpiece pallet from the conveyor medium:
PE 5, see page 8-3
- ▶ A stop gate VE 5/..., see page 9-3, is sufficient for use with a manual workstation that has low requirements for positioning accuracy and if no forces act upon the workpiece pallet

Notice: Permissible load according to the number of rollers, see page 2-9

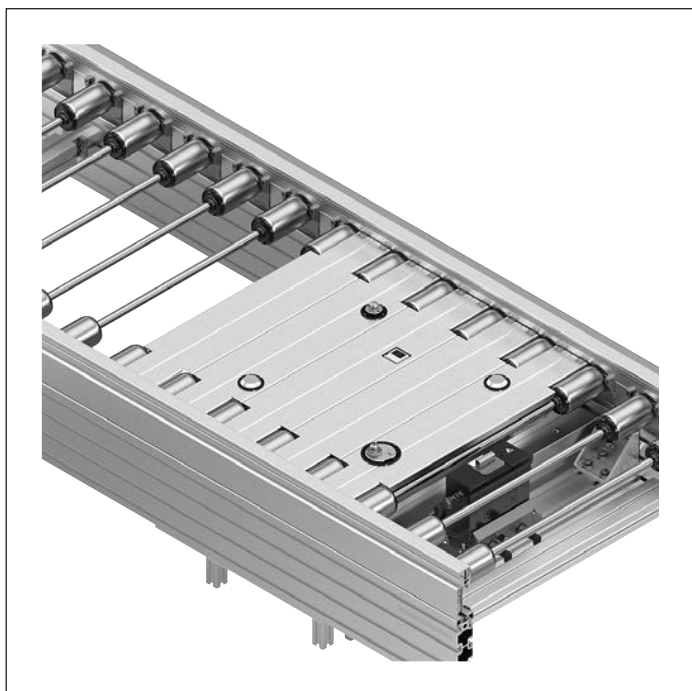

Figures:

Positioning unit PE 5 with protective covers and sleeves in a section ST 5/XH.

Top figure: Bottom position

Bottom figure: Top position

Positioning unit PE 5

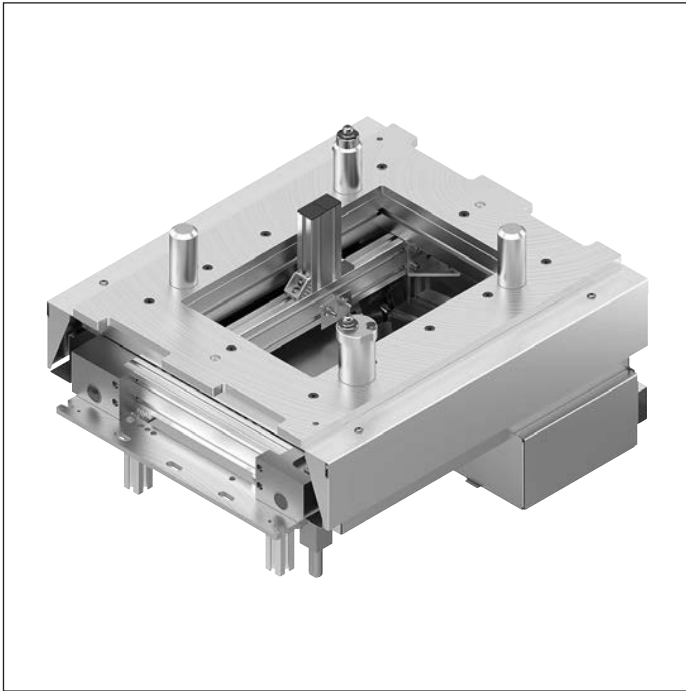

Use

- ▶ Positioning a workpiece pallet in a manual or automated processing station in the longitudinal conveyor with high positioning accuracy requirements (± 0.3 mm)

Version

- ▶ Can be used with all workpiece pallets WT 5
- ▶ Installation from above also possible
- ▶ Lift over transport level: 5 mm
- ▶ Positioning accuracy: ± 0.3 mm in x and y direction
- ▶ Permissible vertical process force with center load: up to 4000 N²⁾ regardless of the WT weight
- ▶ Suitable for ST 5/XH and ST 5/H (not ST 5/XH-FR or ST 5/H-FR)
- ▶ Compressed air connection: 5 ... 6 bar
- ▶ Push in air connection: 8 mm

²⁾ If assembling in a section ST 5/H place legs directly in front of and behind the PE 5.

Scope of delivery

- ▶ Incl. fastening material for mounting the PE 5 in conveyor sections ST 5/XH

Required accessories

- ▶ Assembly kit 3 842 996 185 is required for assembly in conveyor sections ST 5/H, see page 8-21
- ▶ Stop gate VE 5/200, VE 5/D-300, VE 5/D-301 or VE 5/D-1000, see page 9-3ff
- ▶ Switch bracket SH 2/U-H 3 842 537 289, see page 9-22¹⁾
- ▶ Assembly kit SH 2/U-H 3 842 545 132, see page 9-24

¹⁾ Not for size b = 455 mm.

Condition on delivery

- ▶ Assembled

Recommended accessories

- ▶ Cover for the lateral guide, see page 8-24
- ▶ Protective sleeves, see page 8-22

Ordering information

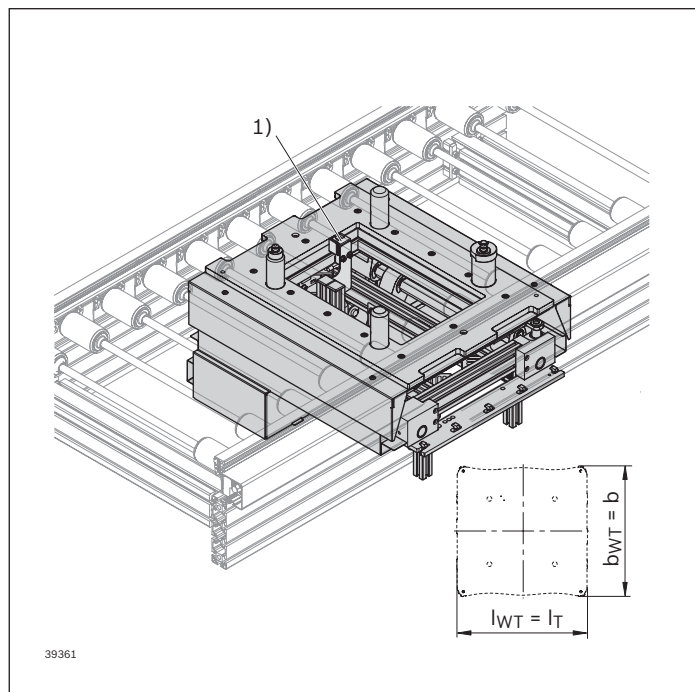

¹⁾ Not for size b = 455 mm

Positioning unit PE 5

b (mm)	l_T (mm)	SC	Material number
455	455	1; 2	3 842 998 786
455	650	1; 2	b = ... mm
650	650	1; 2	l _T = ... mm
650	845	1; 2	SC = ...
845	845	1; 2	
845	1040	1; 2	

b = Track width
l_T = Length in direction of transport
SC = Protective case
1: without protective case
2: with protective case

Positioning unit PE 5 (top/bottom) position inquiry option on request

Description of further parameters, see page 0-3

Circuit diagram

Positioning unit PE 5

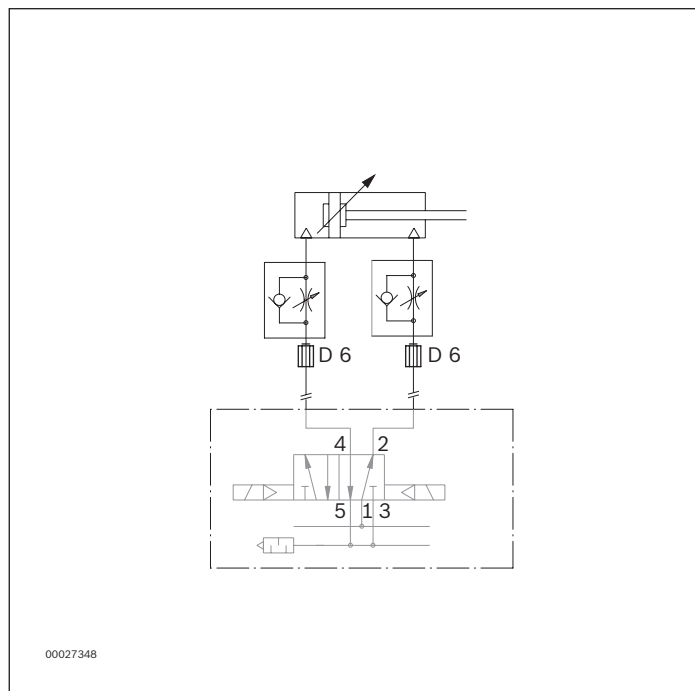

Dimensions
Positioning unit PE 5

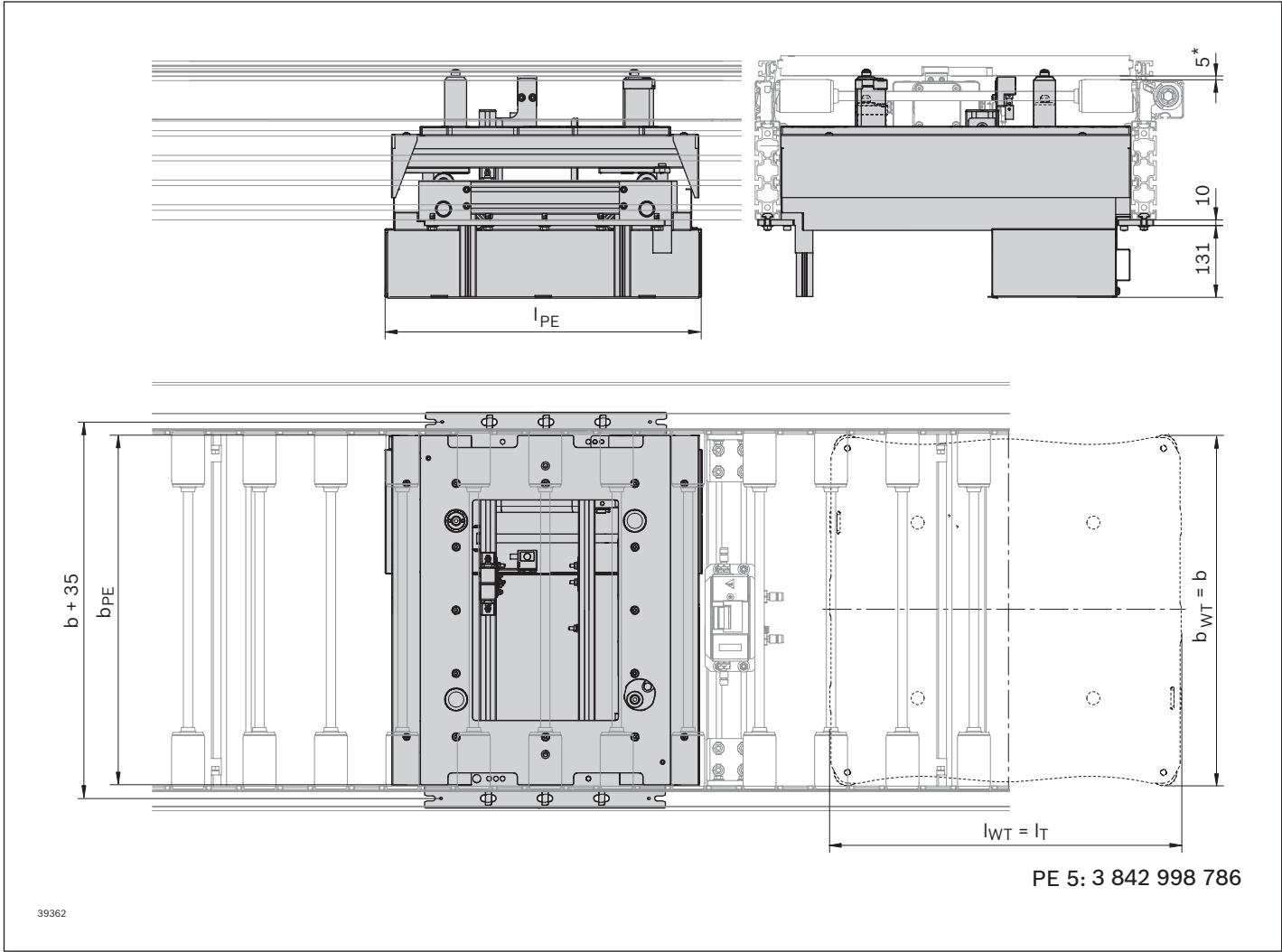

8

* Lift over transport level

b (mm)	l_T (mm)	b_{PE} (mm)	l_{PE} (mm)
455	455	441	471
455	650	441	576
650	650	636	576
650	845	636	764
845	845	831	764
845	1040	831	966

Assembly kit for installing the PE 5 in the ST 5/H: Material number 3 842 996 185, see page 8-21

- b = Track width
- l_T = Length in direction of transport
- b_{PE} = Positioning unit width
- l_{PE} = Positioning unit length

Positioning unit PE 5/T

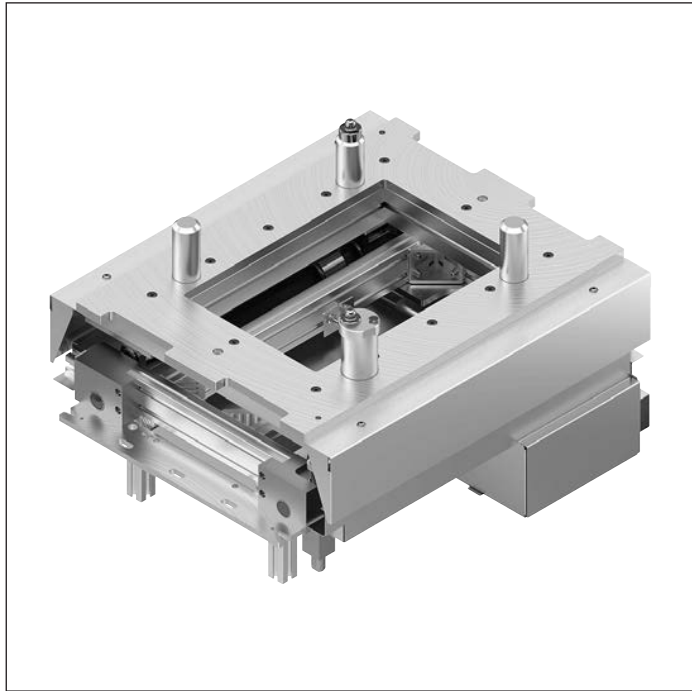

Use

- ▶ Positioning a workpiece pallet in a manual or automated processing station in the transverse conveyor with high positioning accuracy requirements (± 0.3 mm)

Version

- ▶ Can be used with all workpiece pallets WT 5
- ▶ Installation from above also possible
- ▶ Lift over transport level: 5 mm
- ▶ Positioning accuracy: ± 0.3 mm in x and y direction
- ▶ Permissible vertical process force with center load: up to 4000 N²⁾ regardless of the WT weight
- ▶ Suitable for ST 5/XH and ST 5/H (not ST 5/XH-FR or ST 5/H-FR)
- ▶ Compressed air connection: 5 ... 6 bar
- ▶ Push in air connection: 8 mm

²⁾ If assembling in a section ST 5/H, place legs directly in front of and behind the PE 5/T.

Scope of delivery

- ▶ Incl. fastening material for mounting the PE 5/T in conveyor sections ST 5/XH, and stop kit for VE 5/D-300 and VE 5/D-1000

Required accessories

- ▶ Assembly kit 3 842 996 185 is required for assembly in conveyor sections ST 5/H, see page 8-21
- ▶ Stop gate VE 5/200, VE 5/D-300, VE 5/D-301 or VE 5/D-1000, see page 9-3ff¹⁾

¹⁾ A position inquiry for the workpiece pallet on the PE is only possible through use of a stop gate VE 5/D-300 or VE 5/D-1000.

Condition on delivery

- ▶ Assembled

Recommended accessories

- ▶ Cover for the lateral guide, see page 8-24
- ▶ Protective sleeves, see page 8-22

Ordering information

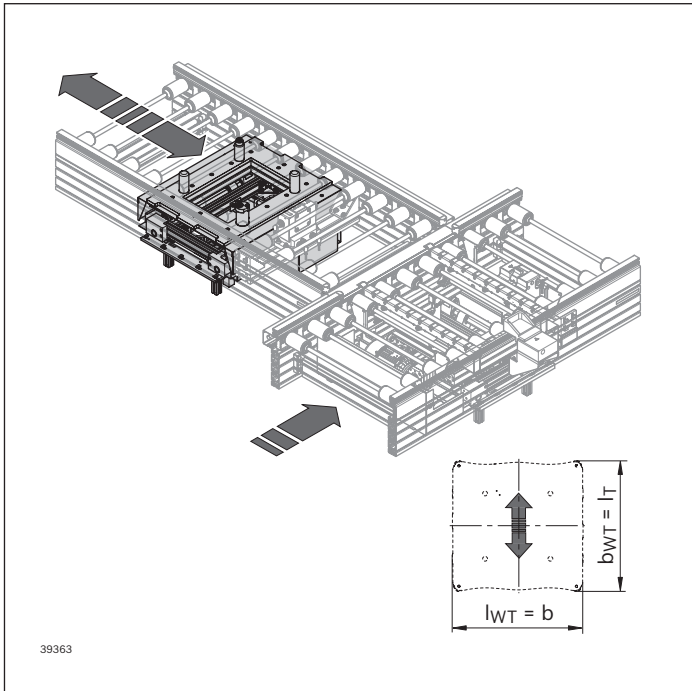

Positioning unit PE 5/T

b (mm)	l_T (mm)	SC	Material number
455	455	1; 2	3 842 998 177
650	455	1; 2	b = ... mm
650	650	1; 2	l _T = ... mm
845	650	1; 2	SC = ...
845	845	1; 2	
1040	845	1; 2	

b = Track width (transverse conveyor width)
 l_T = Length in direction of transport (longitudinal conveyor width)
 SC = Protective case
 1: without protective case
 2: with protective case

Positioning unit PE 5/T (top/bottom) position inquiry option on request

Description of further parameters, see page 0-3

Circuit diagram
Positioning unit PE 5/T

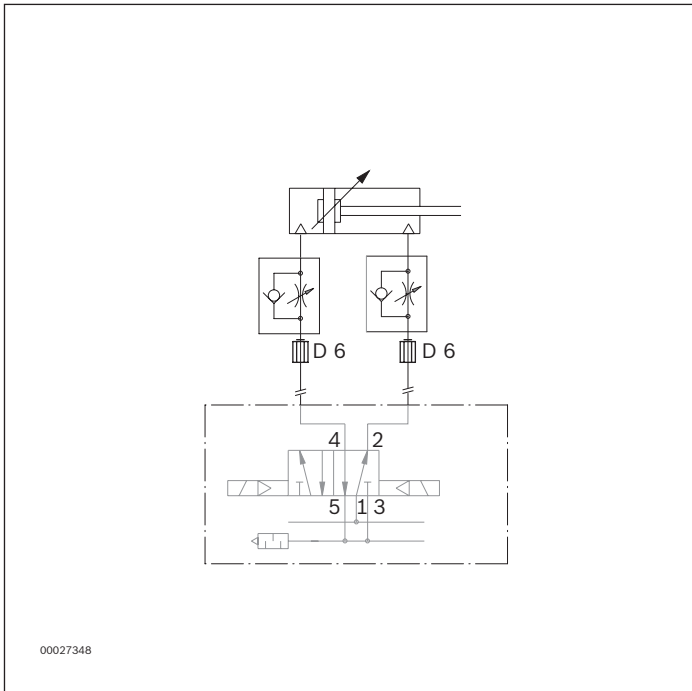

Dimensions

Positioning unit PE 5/T

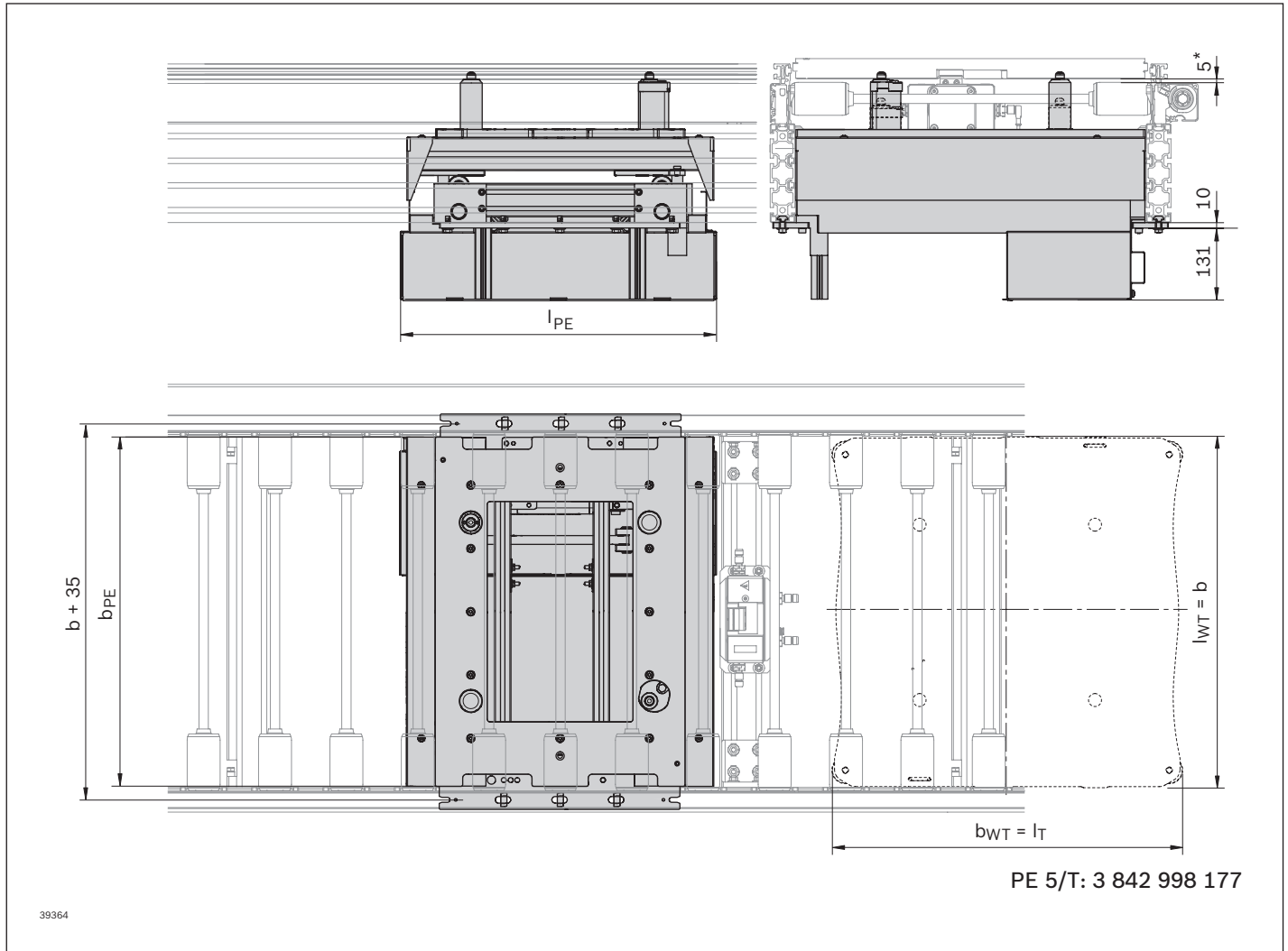

* Lift over transport level

b (mm)	l_T (mm)	b_{PE} (mm)	l_{PE} (mm)
455; 650	455	441	471
650	650	636	576
845	650	636	576
845	845	831	764
1040	845	831	764

Assembly kit for installing the PE 5/T in the ST 5/H: Material number 3 842 996 185, see page 8-21

- b = Track width (transverse conveyor width)
- l_T = Length in direction of transport (longitudinal conveyor width)
- b_{PE} = Positioning unit width
- l_{PE} = Positioning unit length

Positioning unit PE 5/L

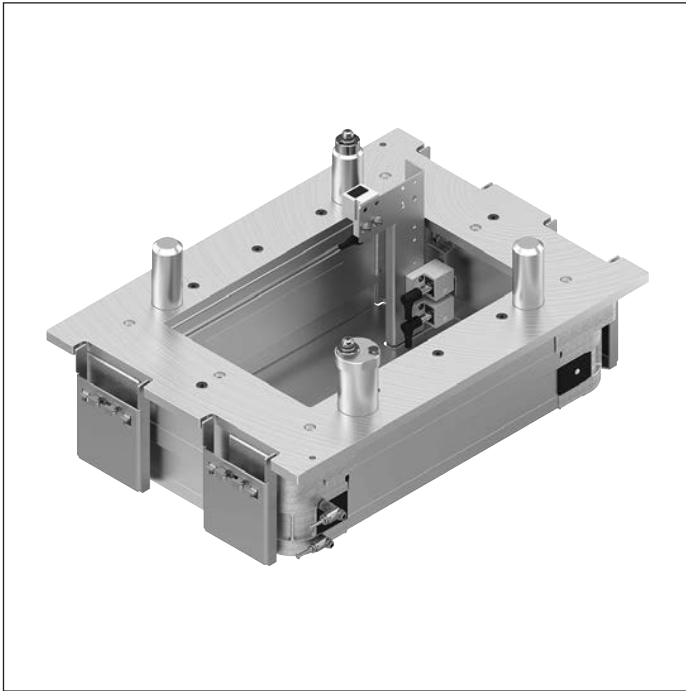

Use

- ▶ Positioning a workpiece pallet in a manual or automated processing station in the longitudinal conveyor with high positioning accuracy requirements (± 0.3 mm)

Version

- ▶ Can be used with all workpiece pallets WT 5
- ▶ Installation only possible from above
- ▶ Lift over transport level: 5 mm
- ▶ Positioning accuracy: ± 0.3 mm in x and y direction
- ▶ Permitted vertical process force with central load: up to 3500 N²⁾ depending on WT weight, i.e. permitted load of 3500 N – weight WT = possible process force
- ▶ Suitable for ST 5/XH and ST 5/H (not ST 5/XH-FR or ST 5/H-FR)
- ▶ Compressed air connection: 5 ... 6 bar
- ▶ Push in air connection: 8 mm

²⁾ If assembling in a section ST 5/H, place legs directly in front of and behind the PE 5/L.

Scope of delivery

- ▶ Incl. fastening material for mounting the PE 5/L in conveyor sections ST 5/XH

Required accessories

- ▶ Stop gate VE 5/200, VE 5/D-300, VE 5/D-301 or VE 5/D-1000, see page 9-3ff
- ▶ Switch bracket SH 2/U-H 3 842 537 289, see page 9-22

Condition on delivery

- ▶ Assembled

Recommended accessories

- ▶ Cover for the lateral guide, see page 8-24
- ▶ Protective sleeves, see page 8-22

Ordering information

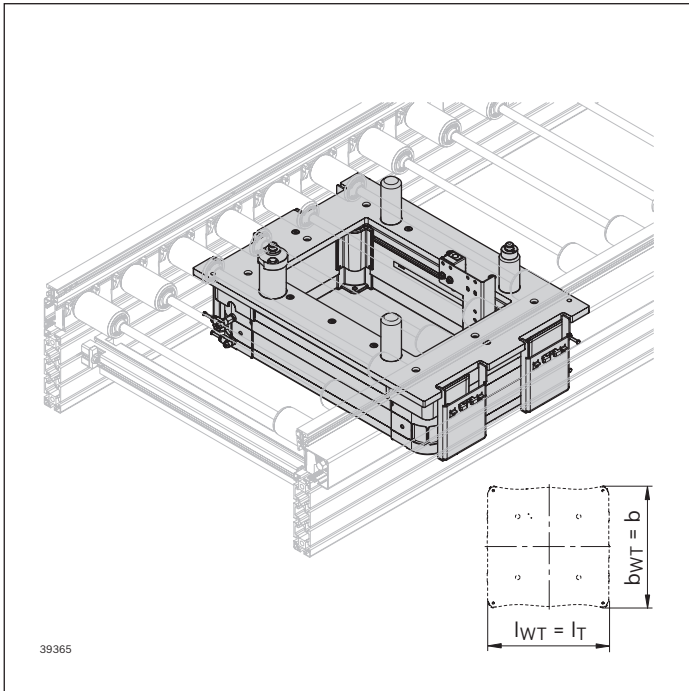

Positioning unit PE 5/L

b (mm)	l_T (mm)	SC	Material number
455	455	1; 2	3 842 998 048
455	650	1; 2	b = ... mm
650	650	1; 2	l _T = ... mm
650	845	1; 2	SC = ...
845	845	1; 2	
845	1040	1; 2	

- b = Track width
- l_T = Length in direction of transport
- SC = Protective case
 - 1: without protective case
 - 2: with protective case

Description of further parameters, see page 0-3

Circuit diagram

Positioning unit PE 5/L

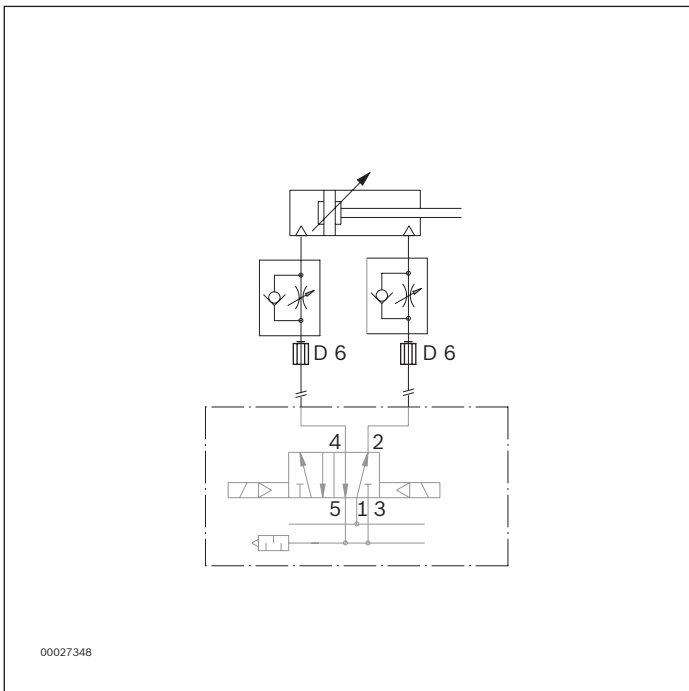

Dimensions

Positioning unit PE 5/L

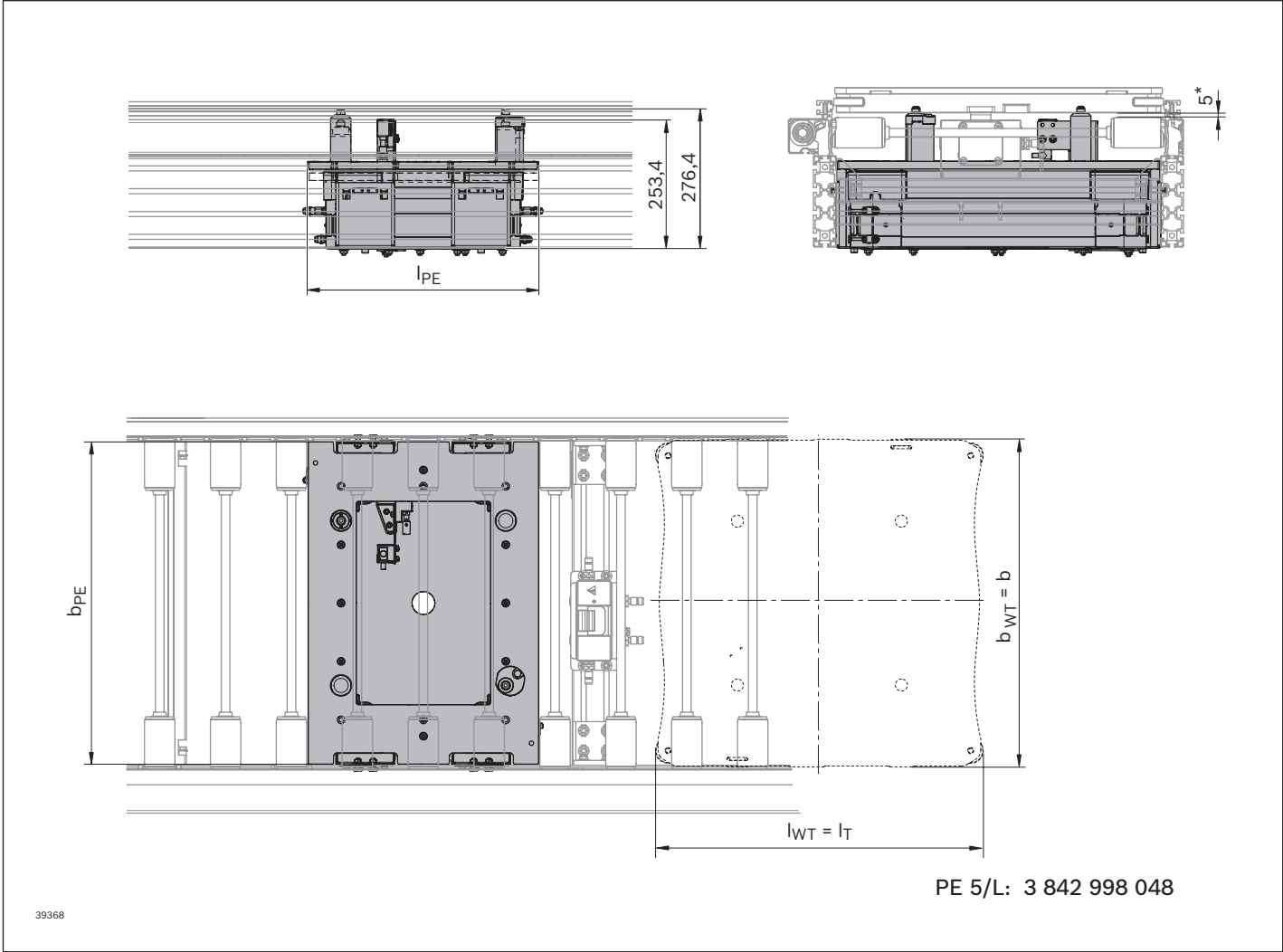

* Lift over transport level

b (mm)	l_T (mm)	b_{PE} (mm)	l_{PE} (mm)
455	455	441	471
455	650	441	576
650	650	636	576
650	845	636	764
845	845	831	764
845	1040	831	966

- b = Track width
- l_T = Length in direction of transport
- b_{PE} = Positioning unit width
- l_{PE} = Positioning unit length

Positioning unit PE 5/L-T

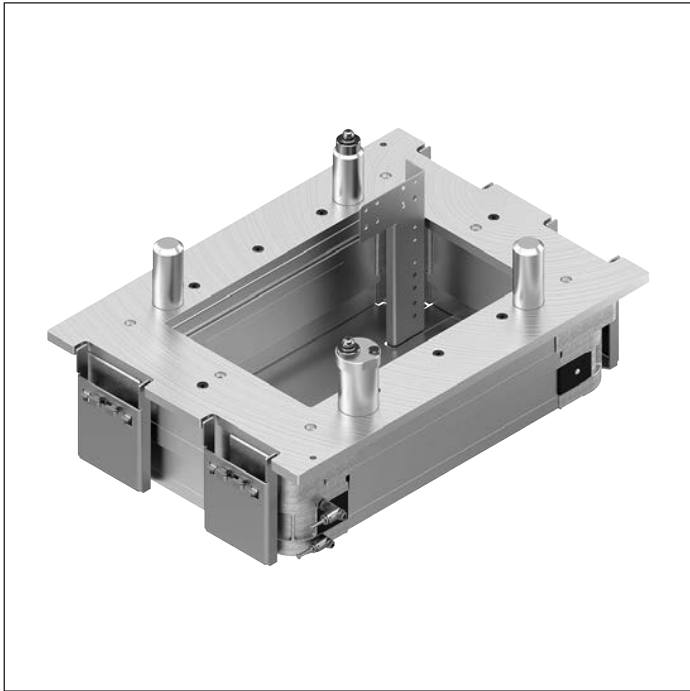

Use

- ▶ Positioning a workpiece pallet in a manual or automated processing station in the transverse conveyor with high positioning accuracy requirements (± 0.3 mm)

Version

- ▶ Can be used with all workpiece pallets WT 5
- ▶ Installation only possible from above
- ▶ Lift over transport level: 5 mm
- ▶ Positioning accuracy: ± 0.3 mm in x and y direction
- ▶ Permitted vertical process force with central load: up to 3500 N²⁾ depending on WT weight, i.e. permitted load of 3500 N – weight WT = possible process force
- ▶ Suitable for ST 5/XH and ST 5/H (not ST 5/XH-FR or ST 5/H-FR)
- ▶ Compressed air connection: 5 ... 6 bar
- ▶ Push in air connection: 8 mm

²⁾ If assembling in a section ST 5/H, place legs directly in front of and behind the PE 5/L-T.

Scope of delivery

- ▶ Incl. fastening material for mounting the PE 5/L-T in conveyor sections ST 5/XH, and stop kit for VE 5/D-300 and VE 5/D-1000.

Required accessories

- ▶ Stop gate VE 5/200, VE 5/D-300, VE 5/D-301 or VE 5/D-1000, see page 9-3ff¹⁾
- ▶ Switch bracket SH 2/U-H 3 842 537 289, see page 9-22

¹⁾ A position inquiry for the workpiece pallet on the PE is only possible through use of a stop gate VE 5/D-300 or VE 5/D-1000.

Condition on delivery

- ▶ Assembled

Recommended accessories

- ▶ Cover for the lateral guide, see page 8-24
- ▶ Protective sleeves, see page 8-22

Ordering information

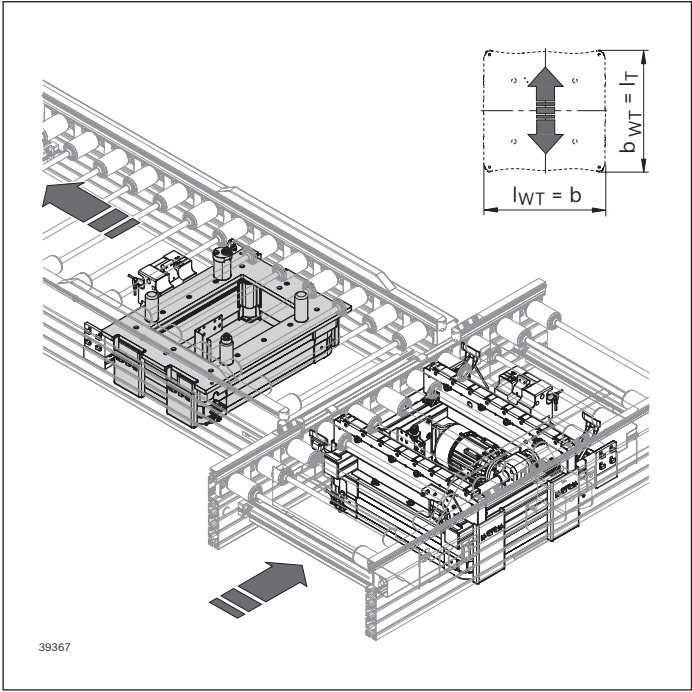

Positioning unit PE 5/LT

b (mm)	l_T (mm)	SC	Material number
455	455	1; 2	3 842 998 049
650	455	1; 2	b = ... mm
650	650	1; 2	l _T = ... mm
845	650	1; 2	SC = ...
845	845	1; 2	
1040	845	1; 2	

b = Track width (transverse conveyor width)
 l_T = Length in direction of transport (longitudinal conveyor width)
 SC = Protective case
 1: without protective case
 2: with protective case

Description of further parameters, see page 0-3

Circuit diagram
Positioning unit PE 5/LT

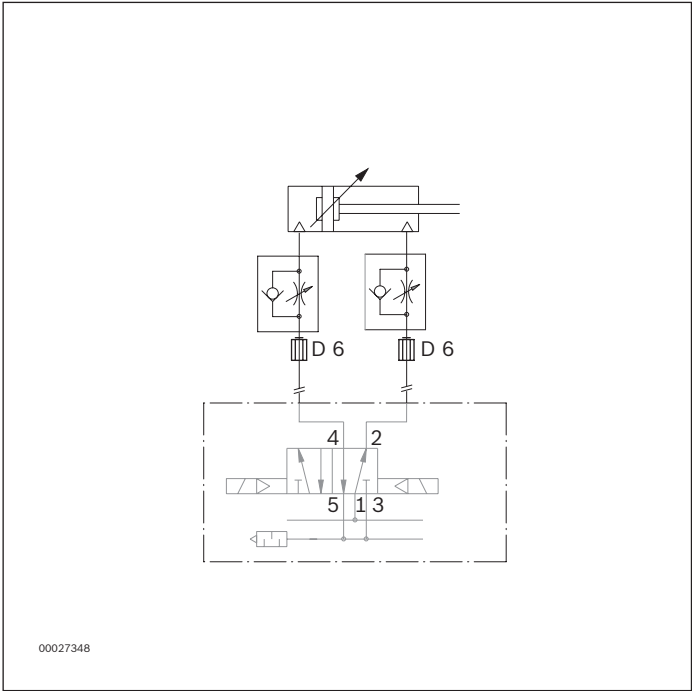

Dimensions

Positioning unit PE 5/LT

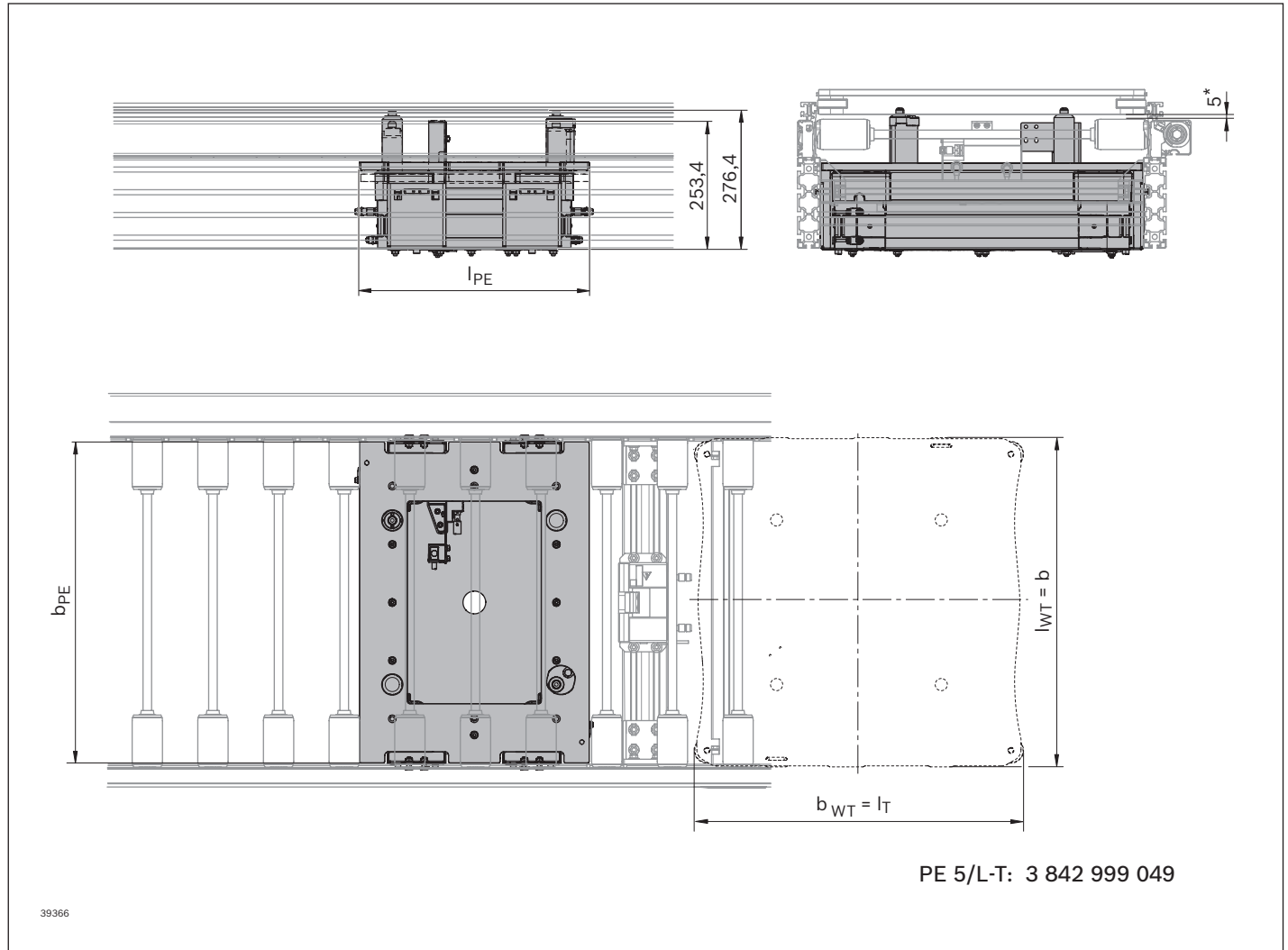

* Lift over transport level

b (mm)	l_T (mm)	b_{PE} (mm)	l_{PE} (mm)
455; 650	455	441	471
650	650	636	576
845	650	636	576
845	845	831	764
1040	845	831	764

- b = Track width (transverse conveyor width)
- l_T = Length in direction of transport (longitudinal conveyor width)
- b_{PE} = Positioning unit width
- l_{PE} = Positioning unit length

Positioning unit PE 5/OC

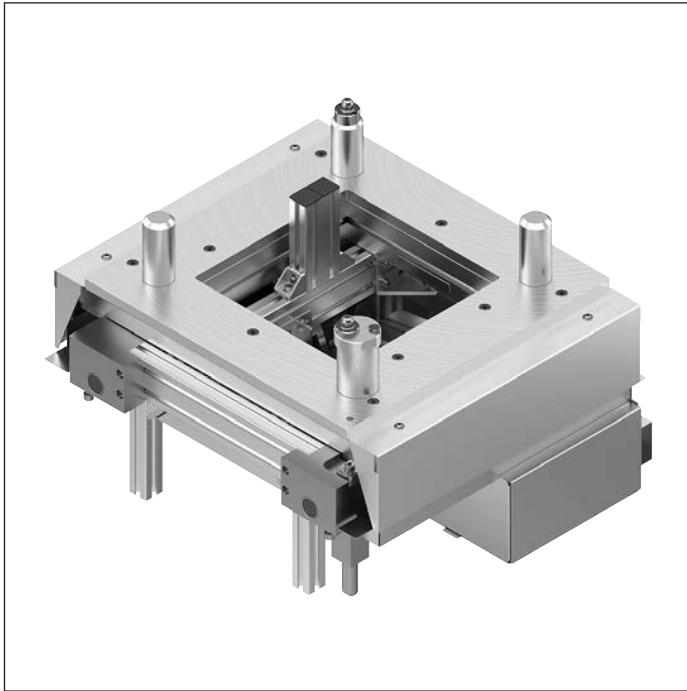

Use

- ▶ Positioning a workpiece pallet in a manual or automated processing station in the longitudinal conveyor with high positioning accuracy requirements (± 0.3 mm)

Version

- ▶ Can be used with all workpiece pallets WT 5
- ▶ Installation from below
- ▶ Lift over transport level: 5 mm
- ▶ Positioning accuracy: ± 0.3 mm in x and y direction
- ▶ Permissible vertical process force with center load: up to 4000 N regardless of the WT weight
- ▶ Suitable for ST 5/OC
- ▶ Compressed air connection: 5 ... 6 bar
- ▶ Push in air connection: 8 mm

Scope of delivery

- ▶ Incl. fastening material for mounting the PE 5/OC in conveyor sections ST 5/OC

Required accessories

- ▶ Stop gate VE 5/200, VE 5/D-300, VE 5/D-301 or VE 5/D-1000, see page 9-3ff
- ▶ Switch bracket SH 2/U-H 3 842 537 289, see page 9-22
- ▶ Assembly kit SH 2/U-H 3 842 545 132, see page 9-24
- ▶ Protective sleeves and protective cover, see page 8-22 and 8-25

Condition on delivery

- ▶ Assembled

Recommended accessories

- ▶ Cover for the lateral guide, see page 8-24
- ▶ Protective cover, see page 8-25

Ordering information

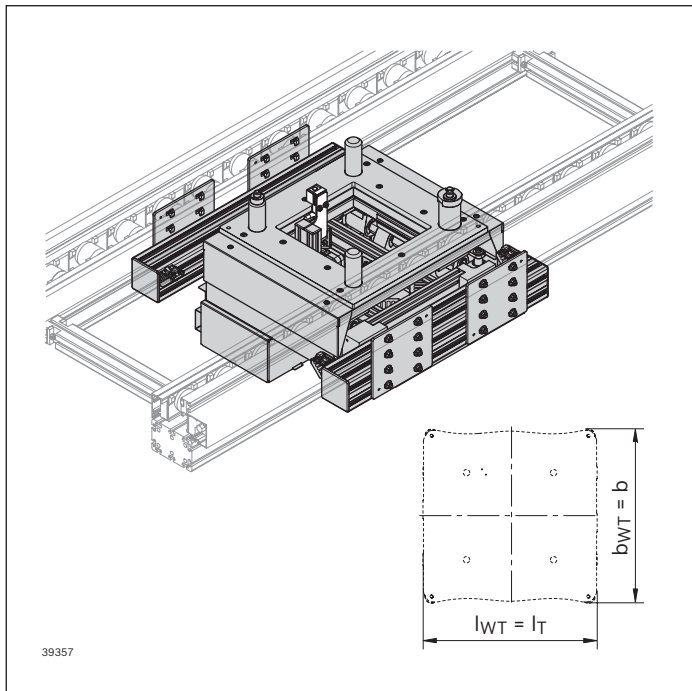

Positioning unit PE 5/OC

b (mm)	l_T (mm)	SC	Material number
455	455	1; 2	3 842 998 178
455	650	1; 2	b = ... mm
650	650	1; 2	l _T = ... mm
650	845	1; 2	SC = ...
845	845	1; 2	
845	1040	1; 2	

b = Track width

l_T = Length in direction of transport

SC = Protective case

1: without protective case

2: with protective case

Positioning unit PE 5/OC (top/bottom) position inquiry option on request

Description of further parameters, see page 0-3

Circuit diagram

Positioning unit PE 5/OC

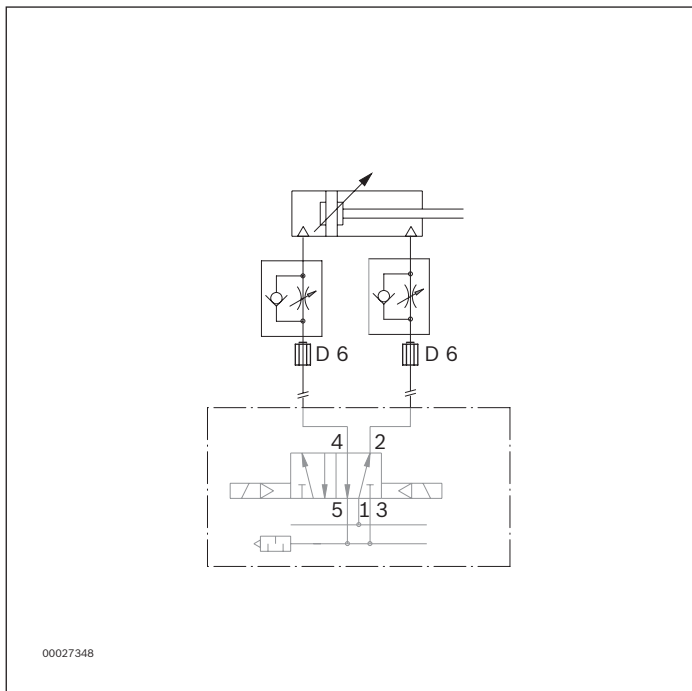

Dimensions

Positioning unit PE 5/OC

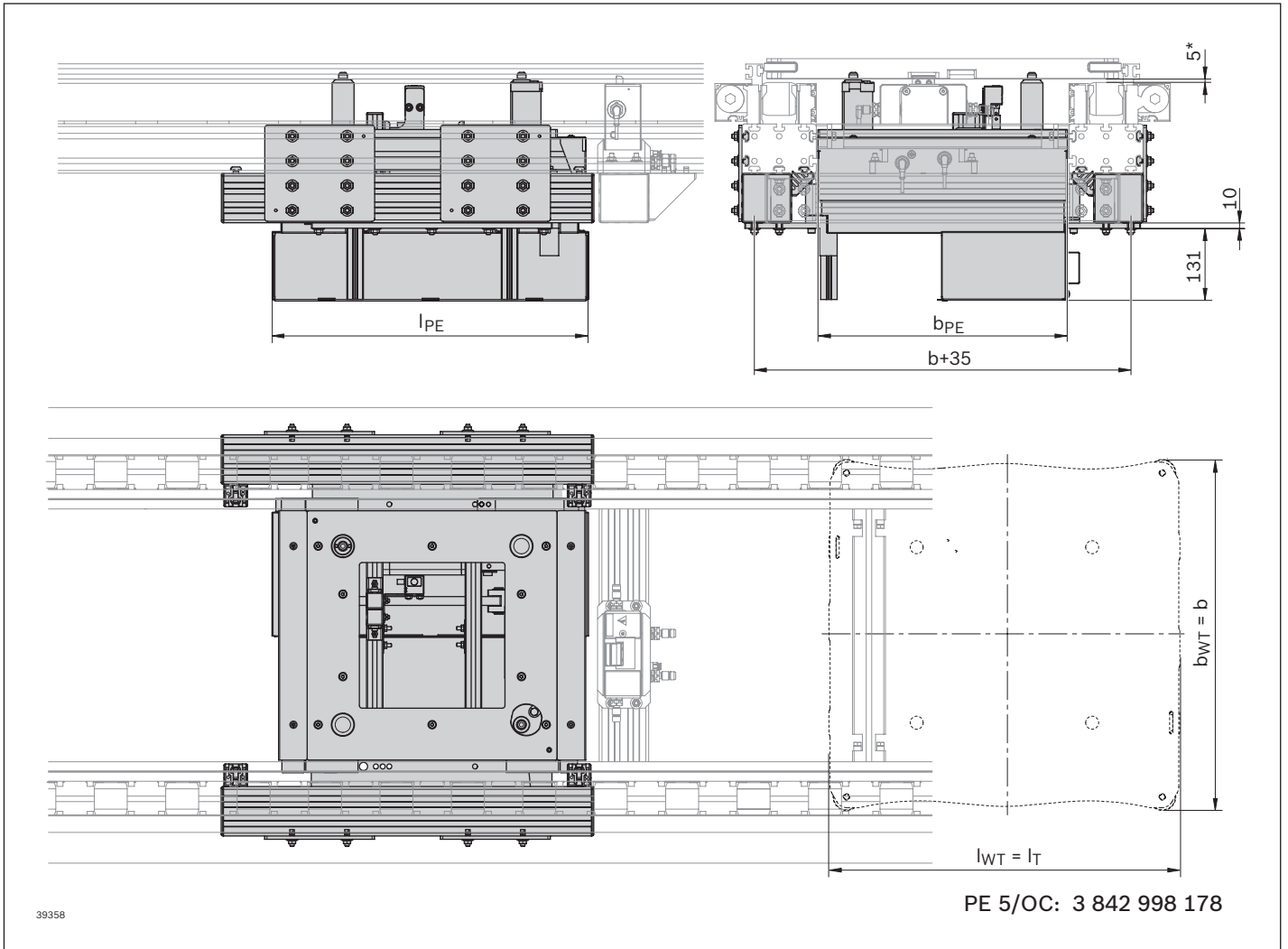

* Lift over transport level

b (mm)	l_T (mm)	b_{PE} (mm)	l_{PE} (mm)
455	455; 650	259	471; 576
650	650	454	576
650	845	454	764
845	845	649	764
845	1040	649	996

b = Track width

l_T = Length in direction of transport

b_{PE} = Positioning unit width

l_{PE} = Positioning unit length

Positioning unit PE 5/OC-T

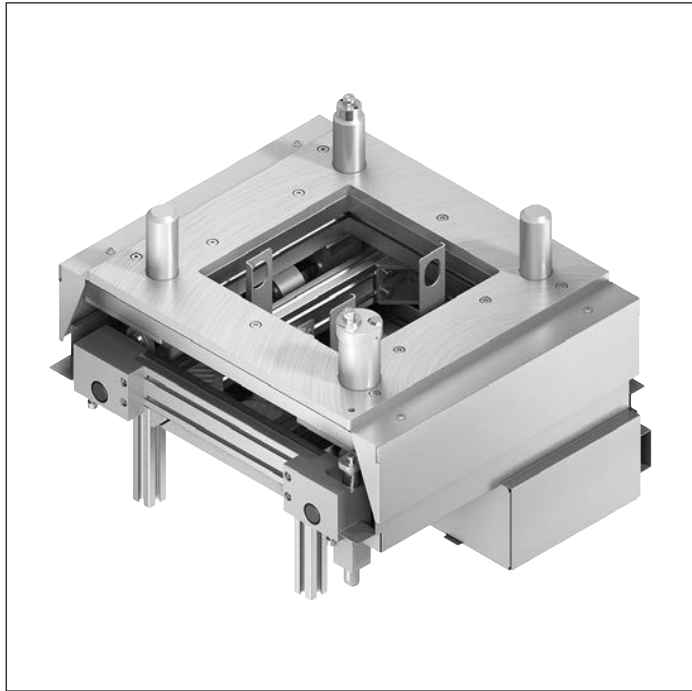

Use

- ▶ Positioning a workpiece pallet in a manual or automated processing station in the transverse conveyor with high positioning accuracy requirements (± 0.3 mm)

Version

- ▶ Can be used with all workpiece pallets WT 5
- ▶ Installation from below
- ▶ Lift over transport level: 5 mm
- ▶ Positioning accuracy: ± 0.3 mm in x and y direction
- ▶ Permissible vertical process force with center load: up to 4000 N regardless of the WT weight
- ▶ Suitable for ST 5/OC
- ▶ Compressed air connection: 5 ... 6 bar
- ▶ Push in air connection: 8 mm

Scope of delivery

- ▶ Incl. fastening material for mounting the PE 5/OC-T in conveyor sections ST 5/OC and stop kit for VE 5/OCD-300 and VE 5/OCD-1000

Required accessories

- ▶ Stop gate VE 5/200, VE 5/D-300, VE 5/D-301 or VE 5/D-1000, see page 9-3ff¹⁾
- ▶ Protective sleeves and protective cover, see page 8-22 and 8-25

¹⁾ A position inquiry for the workpiece pallet on the PE is only possible through use of a stop gate VE 5/OCD-300 or VE 5/OCD-1000.

Condition on delivery

- ▶ Assembled

Recommended accessories

- ▶ Cover for the lateral guide, see page 8-24
- ▶ Protective cover, see page 8-25

Ordering information

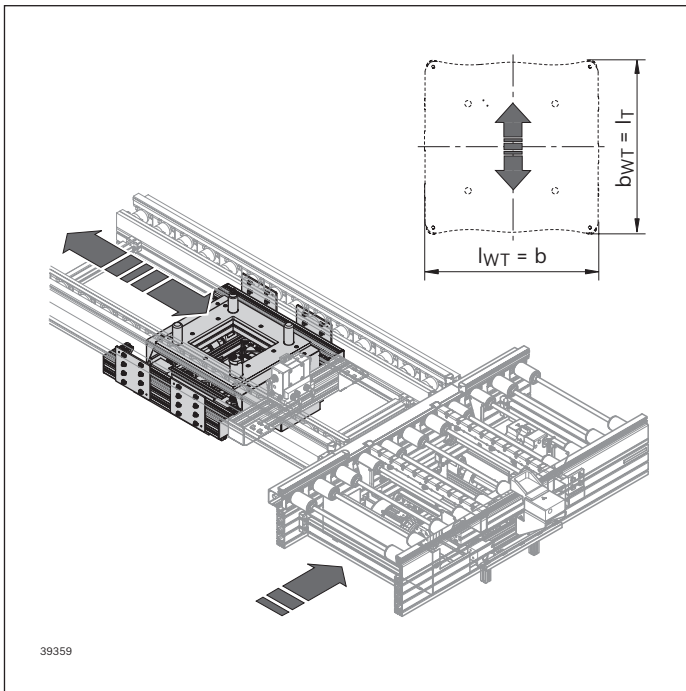

Positioning unit PE 5/OC-T

b (mm)	l _T (mm)	SC	Material number
455	455	1; 2	3 842 998 804
650	455	1; 2	b = ... mm
650	650	1; 2	l _T = ... mm
845	650	1; 2	SC = ... mm
845	845	1; 2	
1040	845	1; 2	

b = Track width (transverse conveyor width)

l_T = Length in direction of transport (longitudinal conveyor width)

SC = Protective case

1: without protective case

2: with protective case

Positioning unit PE 5/OC-T (top/bottom) position inquiry option on request

Description of further parameters, see page 0-3

Circuit diagram

Positioning unit PE 5/OC-T

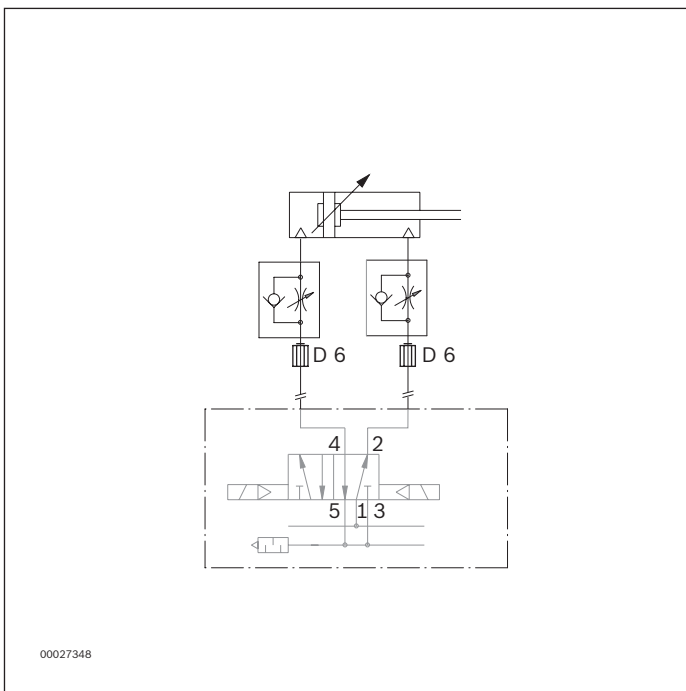

Dimensions

Positioning unit PE 5/OC-T

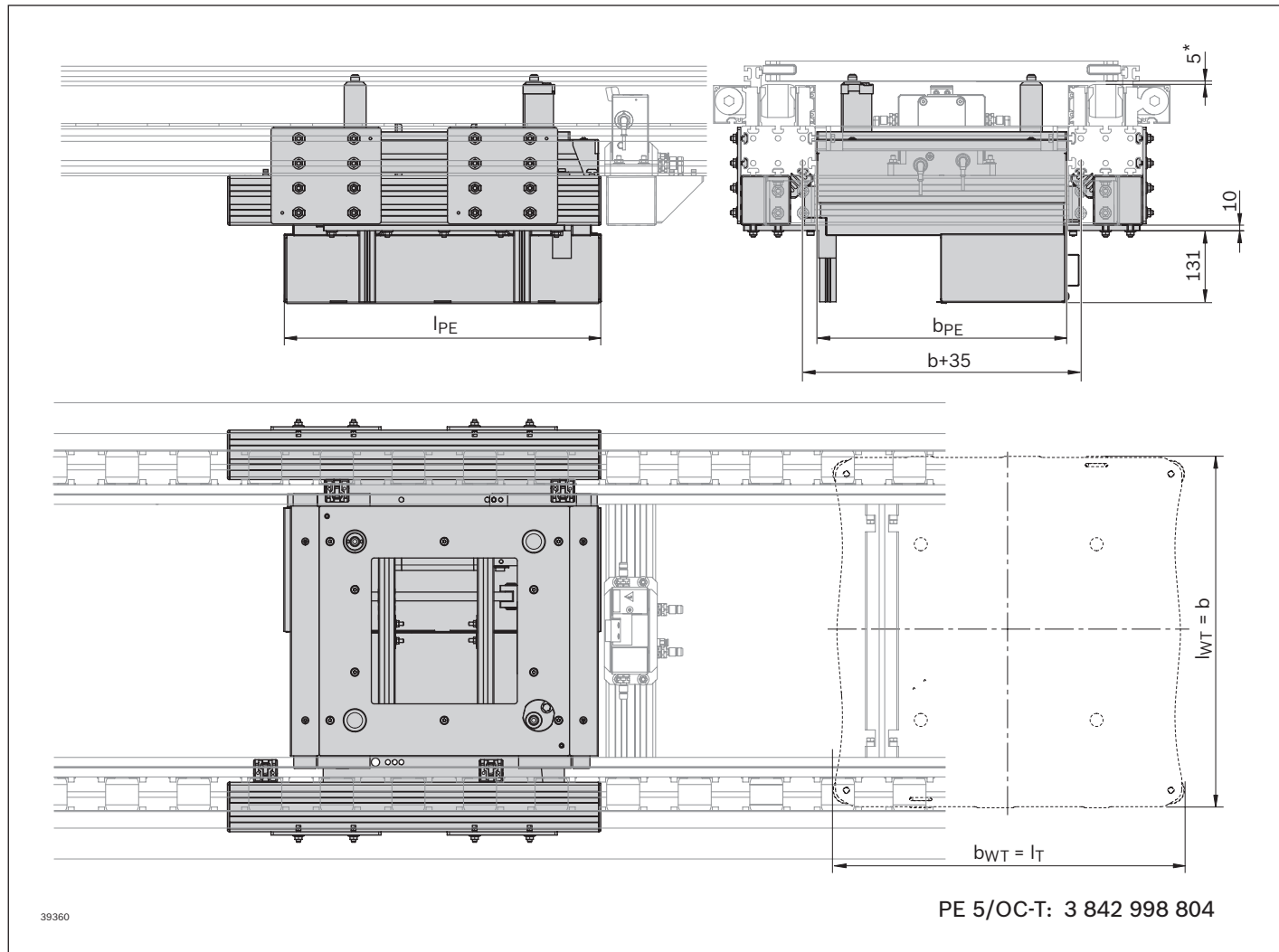

* Lift over transport level

b (mm)	l_T (mm)	b_{PE} (mm)	l_{PE} (mm)
455; 650	455	259; 454	471
650	650	454	576
845	650	649	576
845	845	649	764
1040	845	844	764

- b = Track width (transverse conveyor width)
- l_T = Length in direction of transport (longitudinal conveyor width)
- b_{PE} = Positioning unit width
- l_{PE} = Positioning unit length

Assembly kit for positioning unit PE 5 and PE 5/T

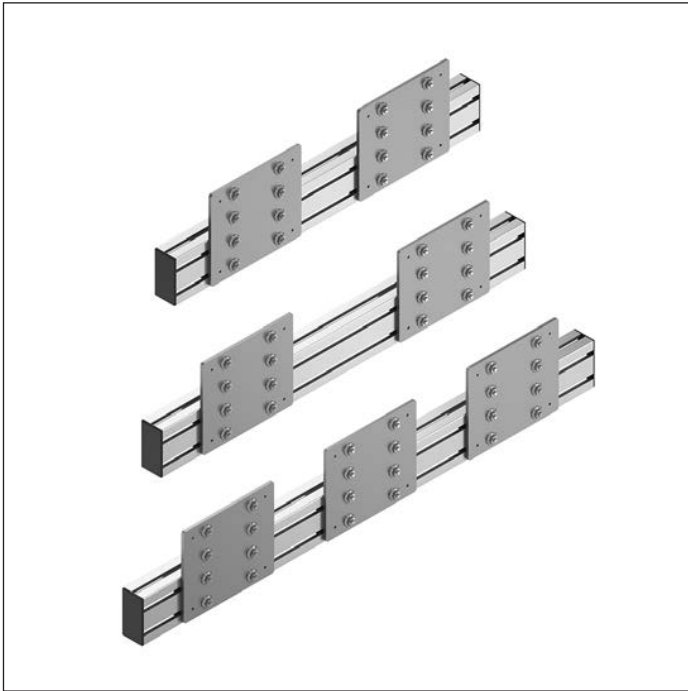

Use

- ▶ Mounting the positioning unit PE 5 and PE 5/T in the conveyor unit ST 5/H, see page 8-3 and 8-6

Version

- ▶ Centering lugs for pre-positioning and fast assembly

Mounting location

- ▶ On the section profile

Scope of delivery

- ▶ 2 profiles for height compensation
- ▶ Incl. cover caps and fastening material for assembly

Condition on delivery

- ▶ Not assembled

Ordering information

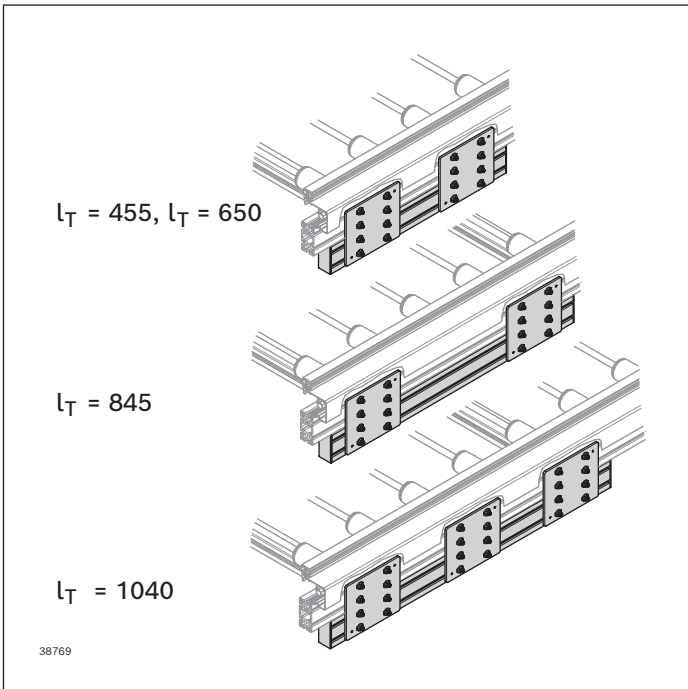

Assembly kit for PE 5 and PE 5/T

l_T	Material number
455; 650; 845; 1040	3 842 996 185
	$l_T = \dots \text{ mm}$

l_T = Length in direction of transport

Protective sleeves for PE 5, PE 5/T, PE 5/L and PE 5/L-T

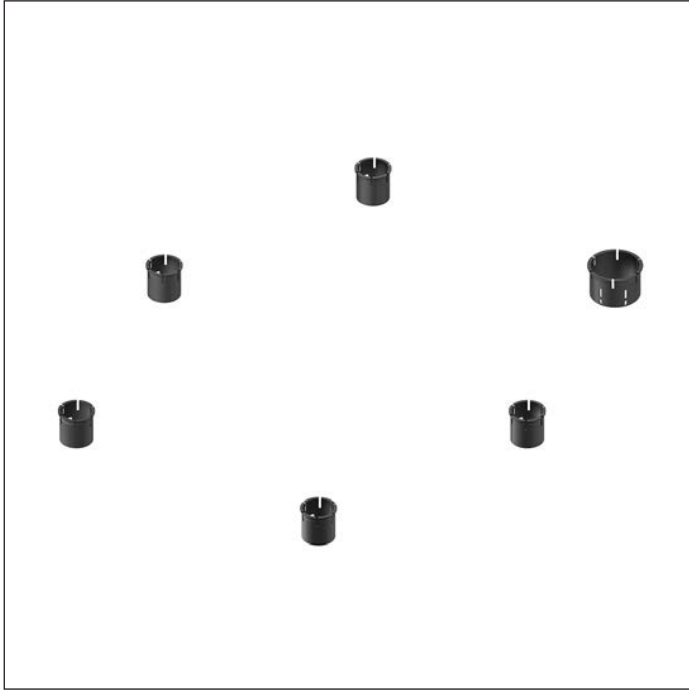

Use

- ▶ Trap guard to clip in the openings in the protective covers over the lifting plungers of the PE 5, PE 5/T, PE 5/L and PE 5/L-T. Refer to the assembly instructions for the installation dimensions.

Notice: Do not walk on the protective covers. Slots for add-on parts must be made by the customer; for details, see assembly instructions.

Required accessories

- ▶ Protective covers for conveyor unit, see page 4-8

Material

- ▶ PA

Ordering information

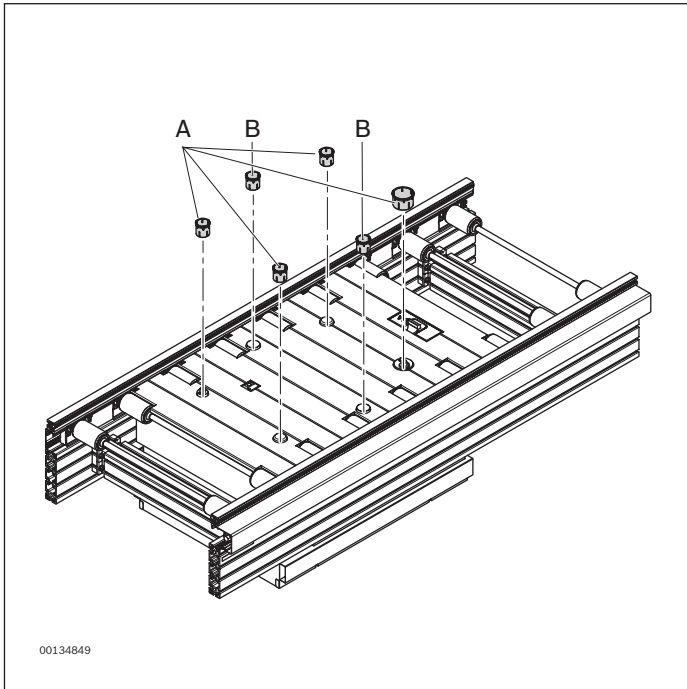

Required protective sleeve sets for PE 5, PE 5/T, PE 5/L and PE 5/LT

b (mm)	l_{WT} (mm)	Material number A	Material number B for PE 5 and PE 5/L	Material number B for PE 5/T and PE 5/LT
455	455	1x 3 842 545 965		
455	650	1x 3 842 545 965		
650	650	1x 3 842 545 965		
650	845	1x 3 842 545 965	+1x 3 842 545 966	+2x 3 842 545 966
845	845	1x 3 842 545 965	+3x 3 842 545 966	+3x 3 842 545 966
845	1040	1x 3 842 545 965	+3x 3 842 545 966	+3x 3 842 545 966

b = Track width of the positioning unit in the direction of transport

l_{WT} = Length of workpiece pallet

Cover of lateral guide for positioning units



Use

- The lateral guide covers are provided on both sides in the vicinity of the positioning unit PE 5 (see page 8-3), PE 5/T (see page 8-6), PE 5/L (see page 8-9), PE 5/LT (see page 8-12), PE 5/OC (see page 8-15) and PE 5/OC-T (see page 8-18) to increase safety

Notice: Do not walk on the protective covers.

Material

- Steel, galvanized

Ordering information

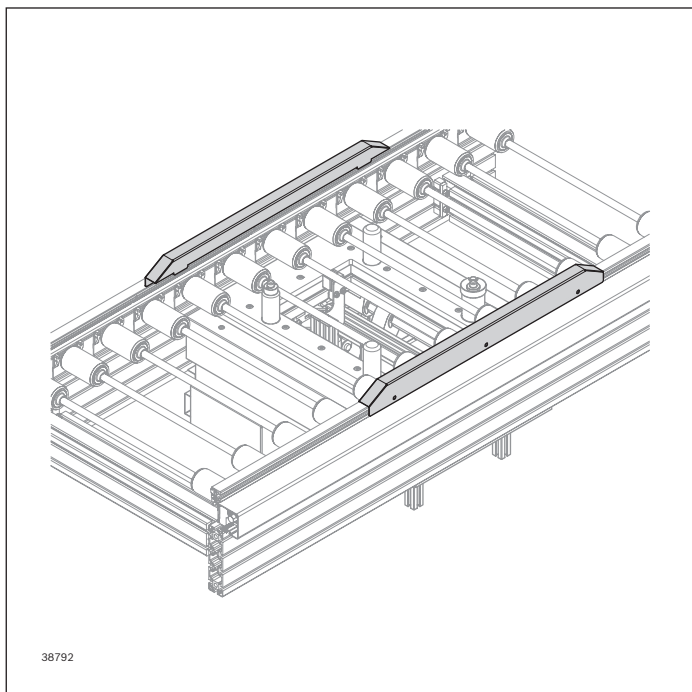

Covers of lateral guide for positioning units

PE 5, PE 5/OC, PE 5/T, PE 5/OC-T	l_T (mm)		Material number
	455	1	3 842 552 662
	650	1	3 842 552 663
	845	1	3 842 552 664
	1040	1	3 842 552 665

l_T = Length in direction of transport

Required fastening materials: T-bolt and flange nut

		Material number
C	100	3 842 345 081
D	100	3 842 528 718

Description of the T-bolt and flange nut, see page 7-10

Protective covers for PE 5/OC and PE 5/OC-T

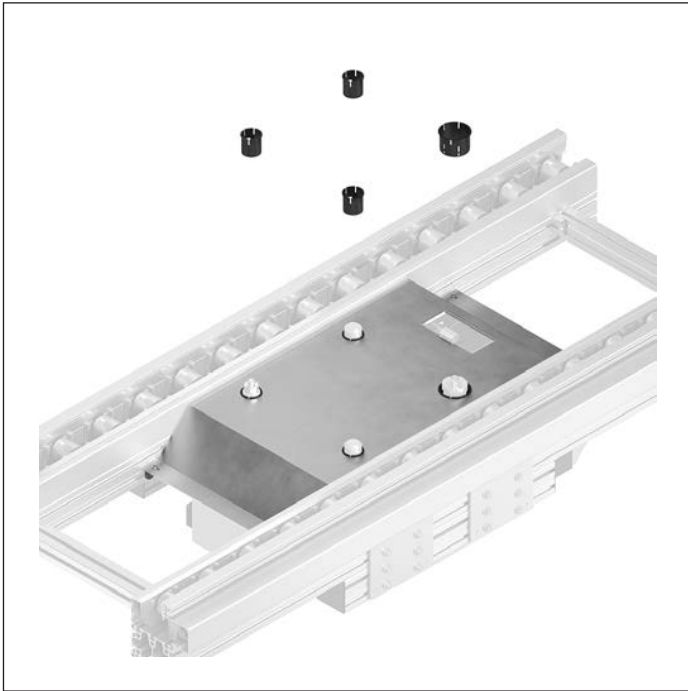

Use

- ▶ Safety guard above the lifting plungers for the PE 5/OC and PE 5/OC-T. Refer to the assembly instructions for the installation dimensions.

Notice: Do not walk on the protective covers.

Scope of delivery

- ▶ Incl. protective sleeves (**A** and **B**) and fastening material

Material

- ▶ Cover: Aluminum
- ▶ Protective sleeves: PA

Condition on delivery

- ▶ Not assembled

Ordering information

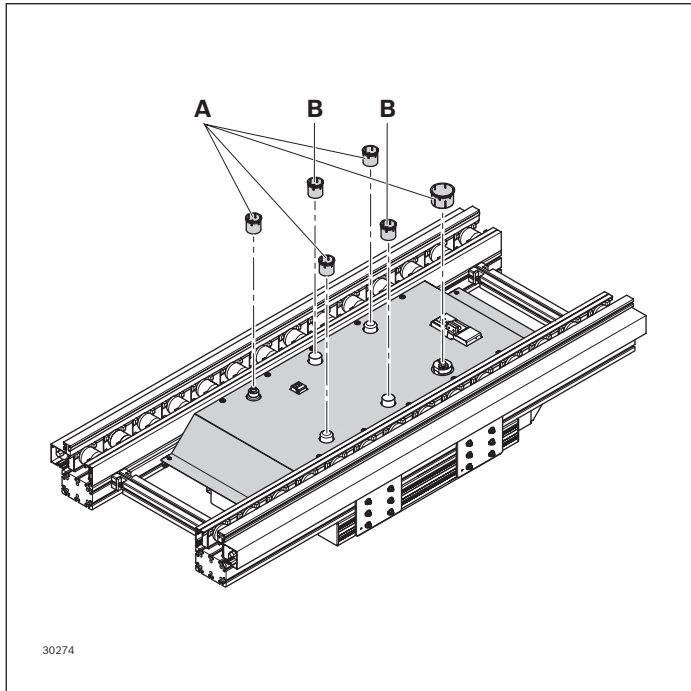

Necessary protective covers including protective sleeves (A and B) for PE 5/OC and PE 5/OC-T

b (mm)	l_T (mm)	PE 5/OC with VE 5/OCD-300 or VE 5/OCD-1000	PE 5/OC-T with VE 5/OCD-300 or VE 5/OCD-1000
455	455	3 842 554 557	3 842 554 569
455	650	3 842 554 558	3 842 554 570
650	650	3 842 554 559	3 842 554 571
650	845	3 842 554 560	3 842 554 572
845	845	3 842 554 561	3 842 554 573
845	1040	3 842 554 562	3 842 554 574

b = Track width of the positioning unit in the direction of transport

l_T = Length in direction of transport

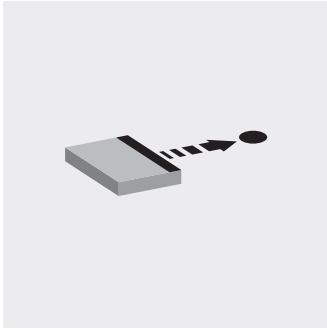

Transportation control

Transportation control	9-2
Stop gate VE 5/200, VE 5/OC-200	9-3
Stop gate VE 5/D-300, VE 5/OCD-300	9-6
Stop gate VE 5/D-301, VE 5/OCD-301	9-9
Stop gate VE 5/D-1000, VE 5/OCD-1000	9-12
Stop gate VE 5/D-1000-E, VE 5/OCD-1000-E	9-15
Clamping holder for sensors	9-18
Sensors with push-in fitting M8x1, M12x1 and M18x1	9-19
Switch bracket SH 2/U-H	9-22
Assembly kit for switch bracket SH 2/U-H	9-24

Transportation control

The modular units for transportation control are used to control the flow of the workpiece pallets on the transfer system. The direction of travel of the workpiece pallet is decisive for proper function of the transportation control. Transportation control includes:

- ▶ Stopping and separating workpiece pallets in the longitudinal conveyor, see page 9-3ff.
- ▶ Stopping workpiece pallets in the transverse conveyor, see page 9-3ff.
Separating workpiece pallets is also possible in the transverse conveyor, see page 9-9
- ▶ Querying the position of a workpiece pallet.
A suitable clamping holder for sensors is required for this, see page 9-18
- ▶ Controlling operation sequences
- ▶ Function plans, see page 13-16 ff.

Stop gate

The stop gates VE 5/... are used to stop and separate workpiece pallets, e.g., in an automated station. Actuation is performed pneumatically. In an unpressurized state, the stop gate is held in the lock position by a spring and thus contributes significantly to production safety. Stop gates are available with and without shock absorbers.

Stop gate VE 5/200, VE 5/OC-200

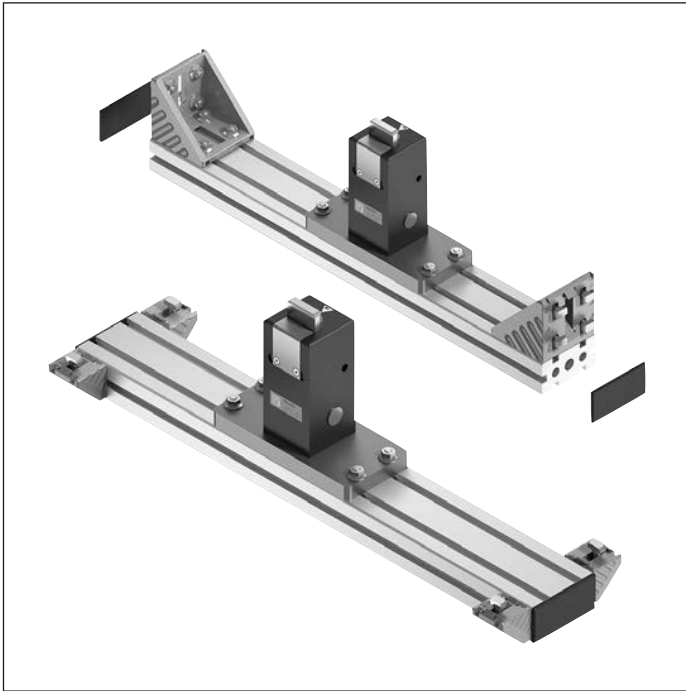

Use

- ▶ Stopping one or more accumulating workpiece pallets at the defined workpiece pallet stop surface

Version

- ▶ Pneumatic stop gate. When the pressure is released, the stop gate is held in the lock position by a spring and the workpiece pallet is stopped.
- ▶ Compressed air connection: 5 ... 6 bar
- ▶ Push in air connection: 6 mm

Scope of delivery

- ▶ Incl. fastening material for assembly on the conveyor section; push in air connection \varnothing 6 mm

Recommended accessories

- ▶ 1 sensor 3 842 549 811 or 3 842 549 814 for position inquiry (engaged, top position/not engaged, bottom position), see page 9-19
- ▶ Clamping holder for sensor, see page 9-18

Condition on delivery

- ▶ Not assembled

Ordering information

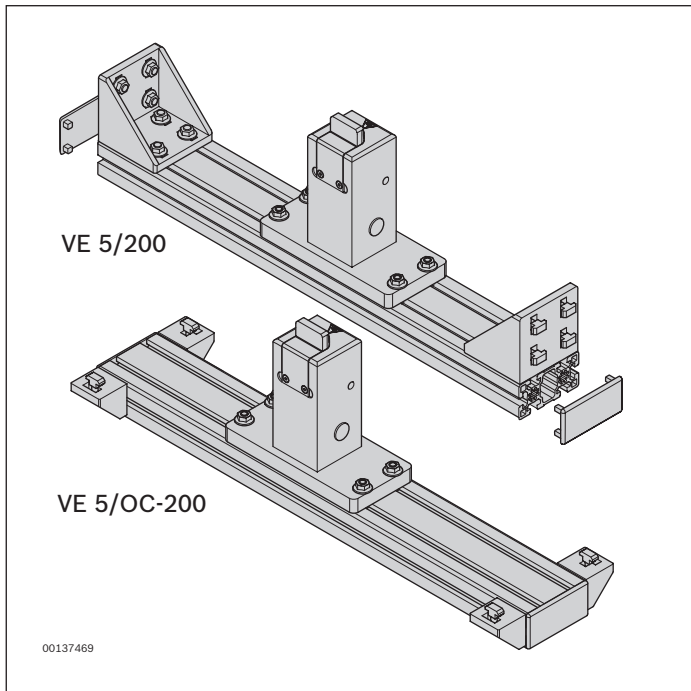

Stop gate VE 5/200

b (mm)	Material number
455; 650; 845; 1040	3 842 998 518
	b = ... mm

b = Track width

Stop gate VE 5/OC-200

b (mm)	Material number
400 ... 1500	3 842 998 577
	b = ... mm

b = Track width

Permissible impact force per WT

m_{WT} (kg)	v_N¹⁾ (m/min)
200	2 ... 9

¹⁾ Conveyor speed

Dimensions

Stop gate VE 5/200, VE 5/OC-200

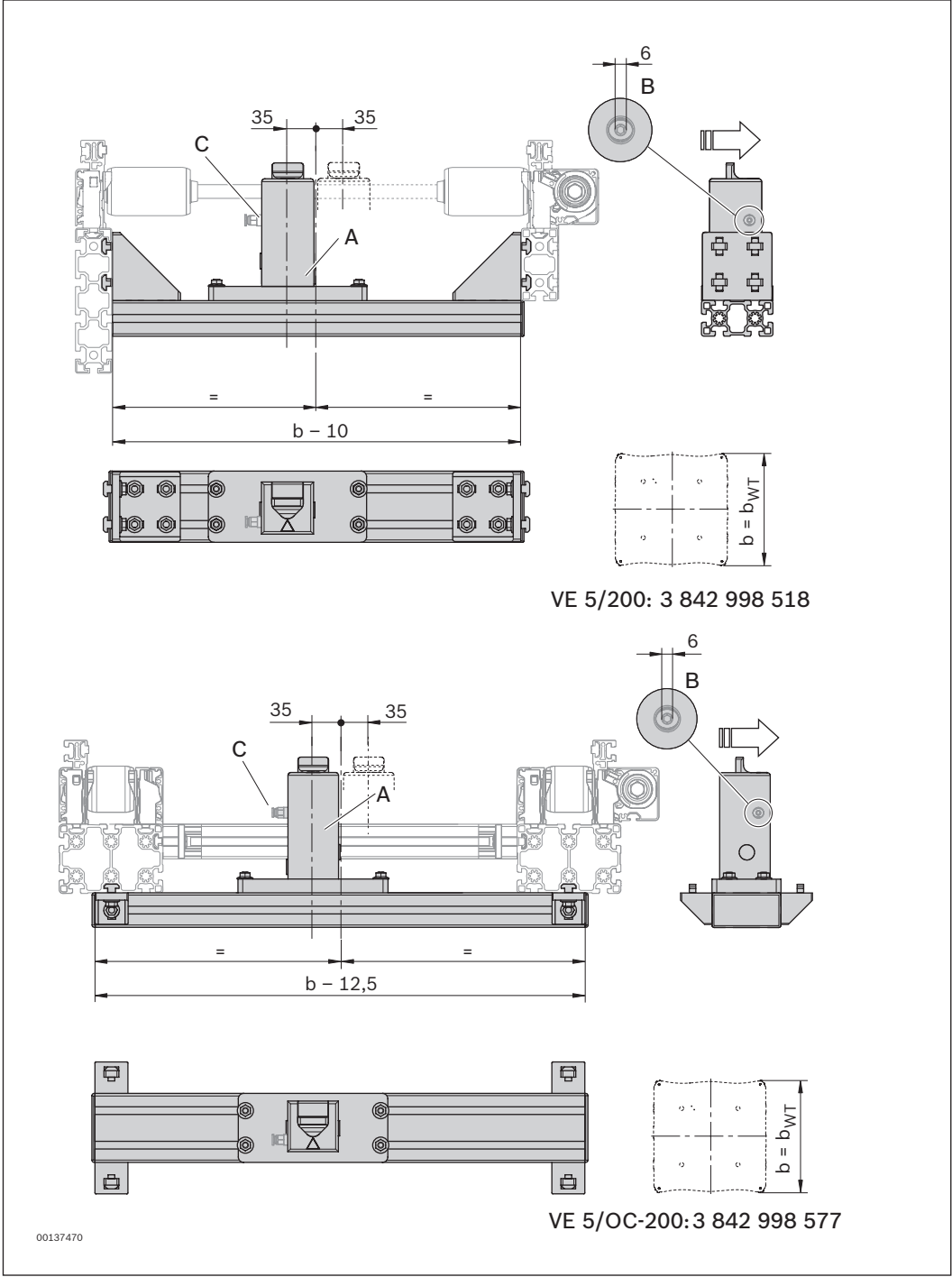

- A = Stop gate
- B = Push in air connection: 6 mm
- C = Position inquiry VE stop blade top: yes/no

Stop gate VE 5/D-300, VE 5/OCD-300

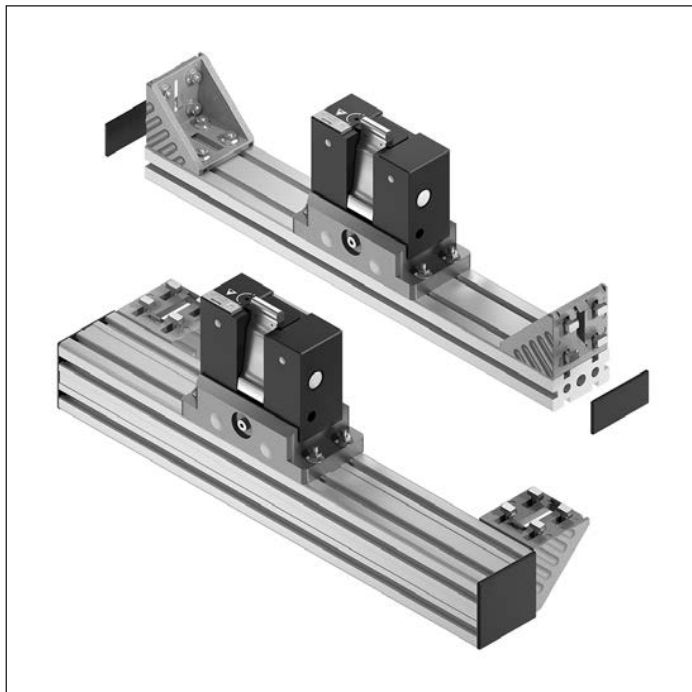

Use

- ▶ Damped stopping of one or more accumulating workpiece pallets at the defined workpiece pallet stop surface

Version

- ▶ Pneumatic stop gate with steplessly adjustable damping. When the pressure is released, the stop gate is held in the lock position by a spring and the workpiece pallet is stopped.
- ▶ Compressed air connection: 5 ... 6 bar
- ▶ Pneumatic connection, pushlock Ø 6 mm

Scope of delivery

- ▶ Incl. fastening material for assembly on the conveyor section; push in air connection Ø 6 mm

Recommended accessories

3 sensors 3 842 549 811 or 3 842 549 814 for position inquiry in respect of

- ▶ Stop gate position inquiry (engaged, top position), see page 9-19
- ▶ Stop gate position inquiry (not engaged, bottom position), see page 9-19
- ▶ Damper position inquiry (stop blade retracted: yes/no), see page 9-19
- ▶ Clamping holder for sensor, see page 9-18
- ▶ Trap guard, see page 9-7

Condition on delivery

- ▶ Not assembled

Ordering information

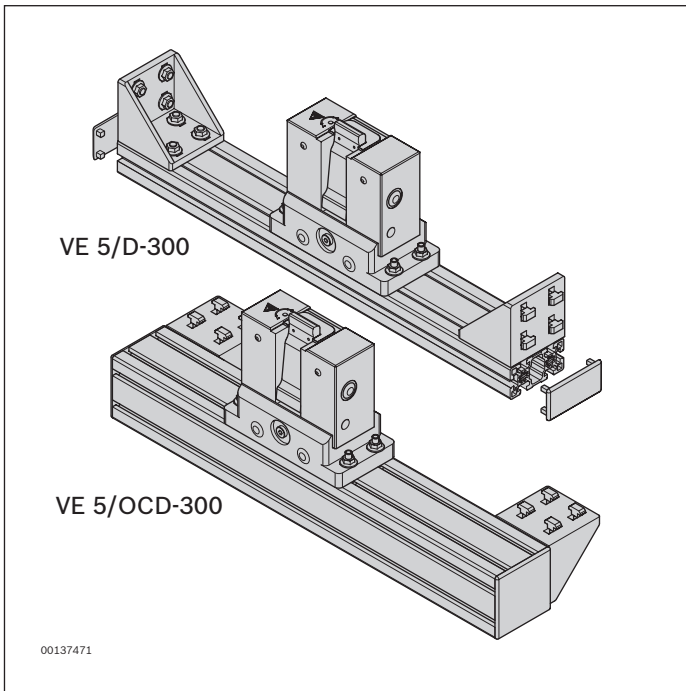

Stop gate VE 5/D-300

b (mm)	Material number
455; 650; 845; 1040	3 842 998 517 b = ... mm

b = Track width

Stop gate VE 5/OCD-300

b (mm)	AO	Material number
400 ... 1500	1; 2; 3; 4	3 842 998 578 b = ... mm

b = Track width

AO = Installation location

- 1: ST 5/OC; AS 5/OC; PE 5/OC; PE 5/OC-T
- 2: PE 5/OC; PE 5/OC-T (b = 455, l_T = 455)
- 3: PE 5/OC (b = 455, l_T = 650)
- 4: PE 5/OC-T (l_T = 455, b = 650)

Permissible impact force per WT

m_{WT} (kg)	v_N¹⁾ (m/min)
max. 300	2 ... 9
max. 260	2 ... 12
max. 160	2 ... 18

¹⁾ Conveyor speed

Trap guard

Material number
3 842 552 672

Dimensions

Stop gate VE 5/D-300, VE 5/OCD-300

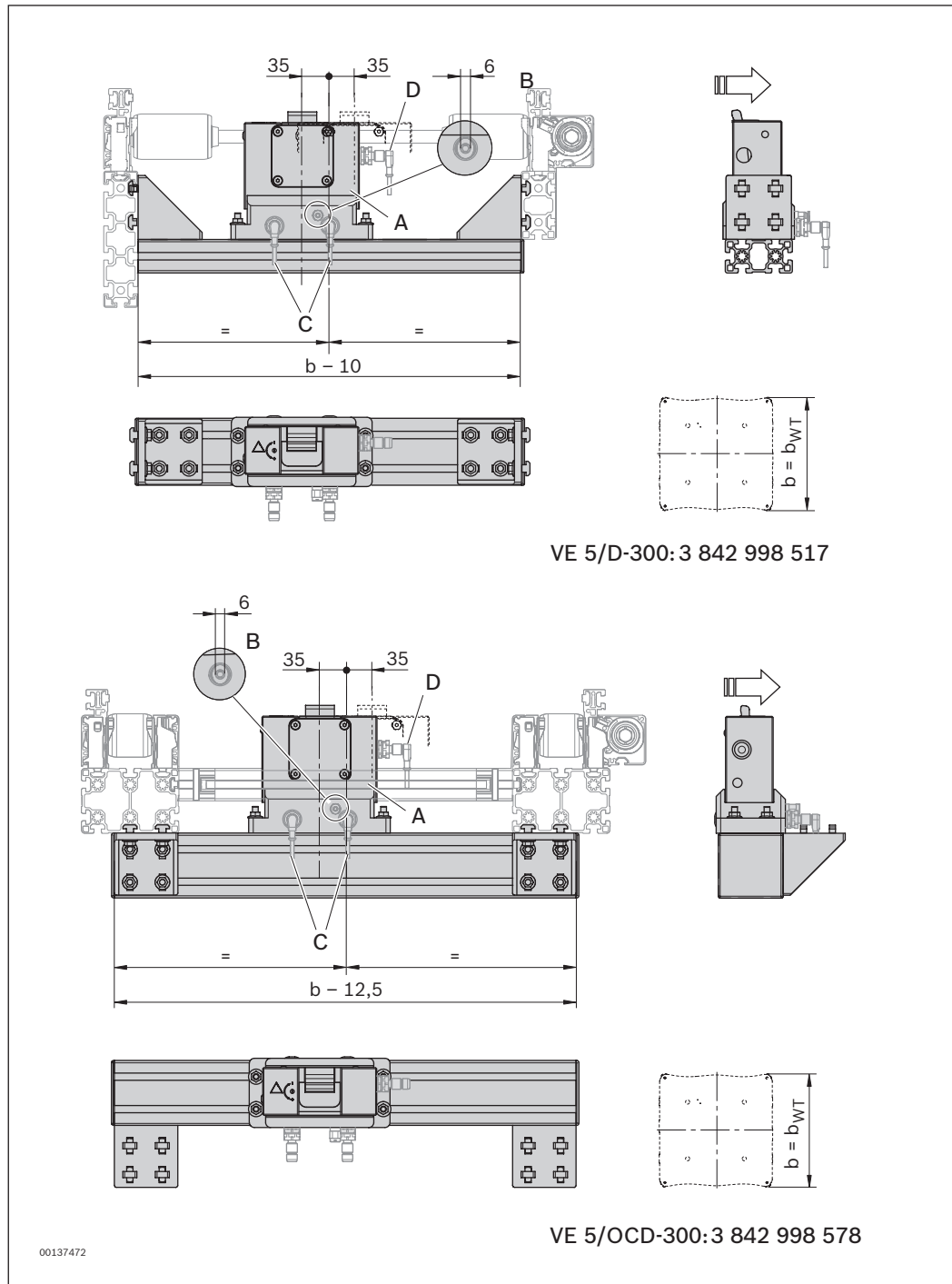

- A = Stop gate
- B = Pneumatic connection, pushlock \varnothing 6 mm
- C = Position inquiry VE stop blade: top/bottom
- D = Position inquiry VE stop blade, damper retracted: yes/no

Stop gate VE 5/D-301, VE 5/OCD-301



Use

- ▶ Damped stopping of one or more accumulating workpiece pallets at the defined workpiece pallet stop surface

Version

- ▶ Pneumatic stop gate with steplessly adjustable damping. When the pressure is released, the stop gate is held in the lock position by a spring and the workpiece pallet is stopped.
- ▶ Compressed air connection: 5 ... 6 bar
- ▶ Pneumatic connection, pushlock Ø 6 mm

Scope of delivery

- ▶ Incl. fastening material for assembly on the conveyor section; push in air connection Ø 6 mm

Recommended accessories

Sensor 3 842 551 761 for

- ▶ Position inquiry top/bottom on request, see page 9-19
- ▶ Damper position inquiry (stop blade retracted), sensor M8, see page 9-19

Condition on delivery

- ▶ Not assembled

Ordering information

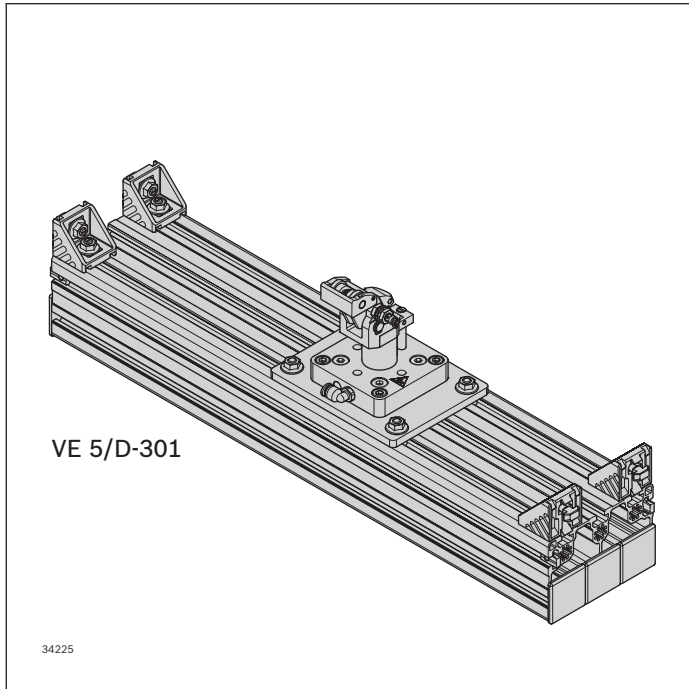

Stop gate VE 5/D-301

b (mm)	AO	Material number
455; 650; 845; 1040	1; 2	3 842 998 079 b = ... mm

b = Track width

AO = Installation location

1: Main section (stop gate is 35 mm eccentric)

2: Transverse section (stop gate is in the center, only applies for transverse section HQ 5)

Stop gate VE 5/OCD-301

b (mm)	AO	Material number
400 ... 1500	1; 2	3 842 998 080 b = ... mm

b = Track width

AO = Installation location

1: Main section (stop gate is 35 mm eccentric)

2: Transverse section (stop gate is in the center, only applies for transverse section HQ 5)

Permissible impact force per WT

m_{WT} (kg)	v_N¹⁾ (m/min)
max. 300	2 ... 9
max. 260	2 ... 12
max. 160	2 ... 18

¹⁾ Conveyor speed

Dimensions

Stop gate VE 5/D-301, VE 5/OCD-301

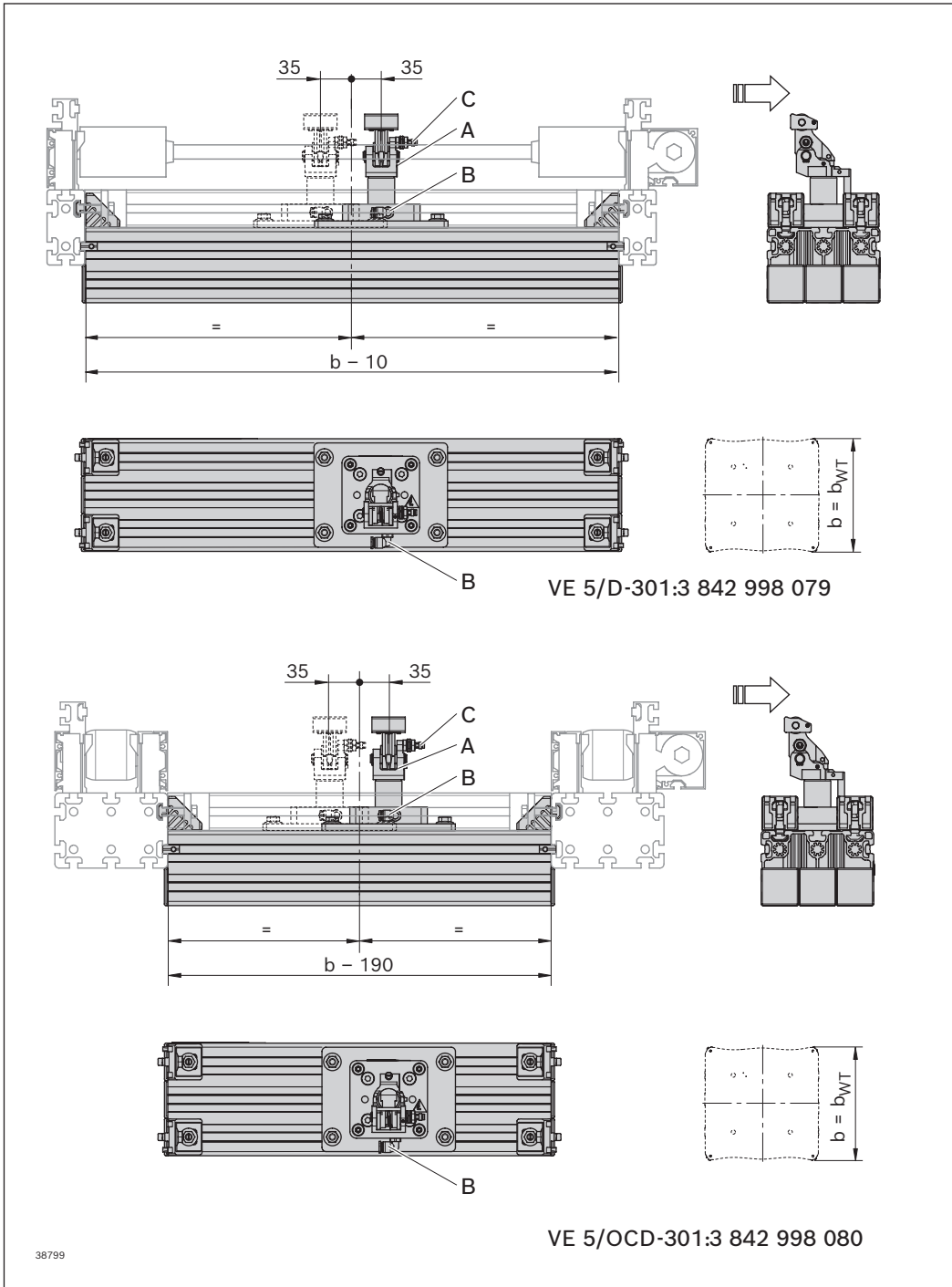

- A = Stop gate
- B = Pneumatic connection, pushlock \varnothing 6 mm
- C = Position inquiry VE stop blade: top/bottom
- D = Position inquiry VE stop blade, damper retracted: yes/no

Stop gate VE 5/D-1000, VE 5/OCD-1000

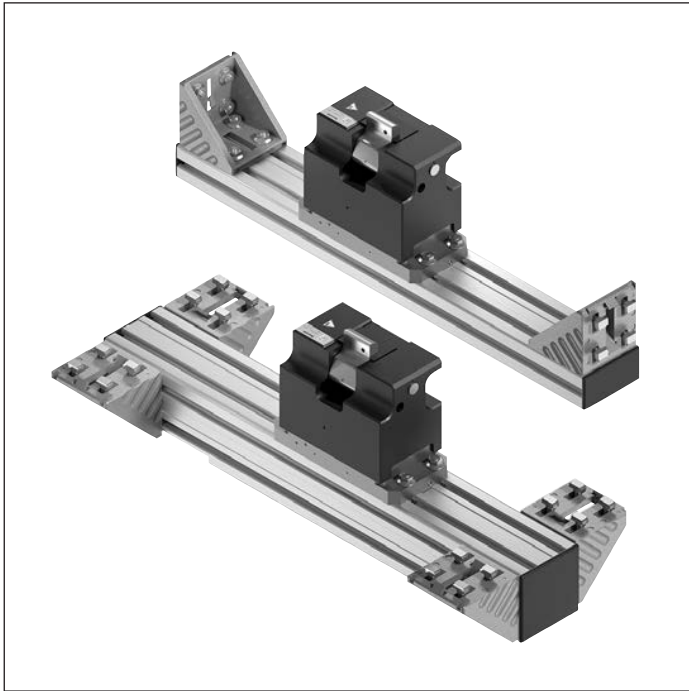

Use

- ▶ Oil-damped stopping of one or more accumulating workpiece pallets at the defined workpiece pallet stop surface

Version

- ▶ Pneumatic stop gate. When the pressure is released, the stop gate is held in the lock position by a spring and the workpiece pallet is stopped.
- ▶ Compressed air connection: 5 ... 6 bar
- ▶ Pneumatic connection, pushlock Ø 6 mm

Notice: Cannot be combined with ST 5/H-FR and ST 5/XH-FR if spacing $p = 130$.

Scope of delivery

- ▶ Incl. fastening material for assembly on the conveyor section; push in air connection Ø 6 mm

Recommended accessories

2 or 3 sensors 3 842 549 811 or 3 842 549 814 for

- ▶ Stop gate position inquiry (engaged, top position), see page 9-19
- ▶ Stop gate position inquiry (not engaged, bottom position), see page 9-19
- ▶ Damper position inquiry (stop blade retracted: yes/no), see page 9-19
- ▶ Clamping holder for sensor, see page 9-18
- ▶ Trap guard, see page 9-13

Condition on delivery

- ▶ Not assembled

Ordering information

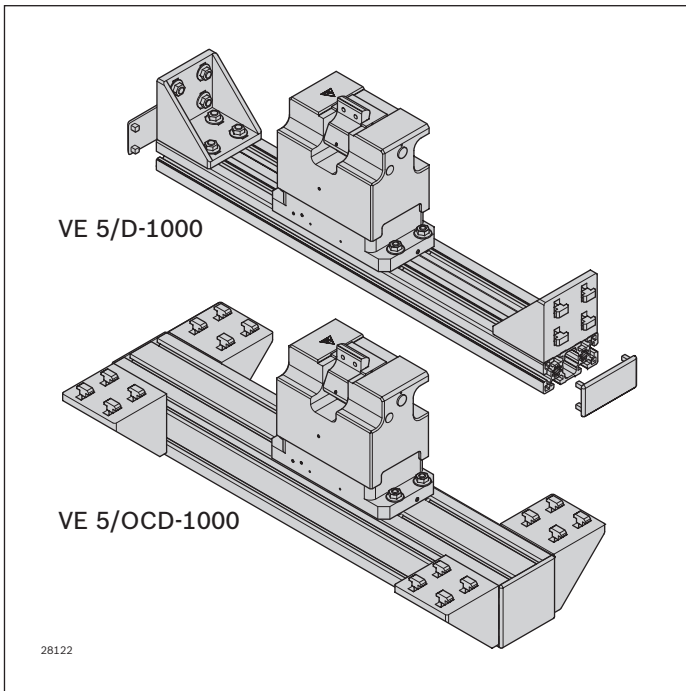

Stop gate VE 5/D-1000

b (mm)	Material number
455; 650; 845; 1040	3 842 998 805
b = ... mm	

b = Track width

Stop gate VE 5/OCD-1000

b (mm)	AO	Material number
400 ... 1500	1; 2; 3; 4	3 842 998 806
b = ... mm		

b = Track width

AO = Installation location

- 1: ST 5/OC; AS 5/OC; PE 5/OC; PE 5/OC-T
- 2: PE 5/OC; PE 5/OC-T (b = 455, l_T = 455)
- 3: PE 5/OC (b = 455, l_T = 650)
- 4: PE 5/OC-T (l_T = 455, b = 650)

Permissible impact force per WT

m_{WT} (kg)	v_N¹⁾ (m/min)
50 ... 1000	2 ... 9
50 ... 900	2 ... 12
50 ... 700	2 ... 18

¹⁾ Conveyor speed

Trap guard

Material number
3 842 552 672

Dimensions

Stop gate VE 5/D-1000, VE 5/OCD-1000

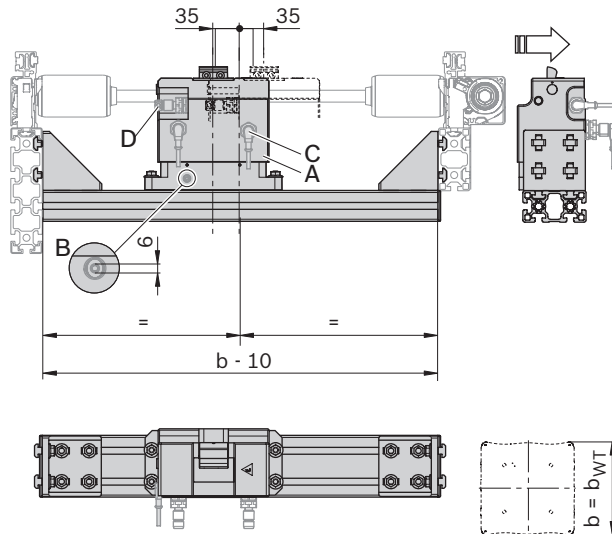

VE 5/D-1000: 3 842 998 805

28123

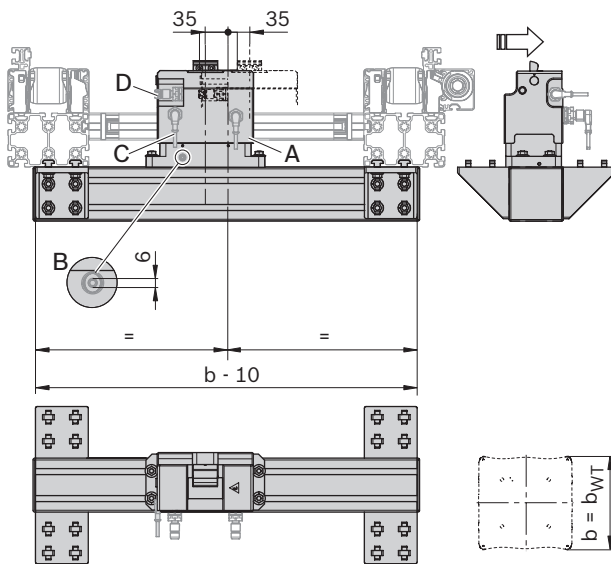

VE 5/OCD-1000: 3 842 998 806

28124

- A = Stop gate
- B = Pneumatic connection, pushlock \varnothing 6 mm
- C = Position inquiry VE stop blade: top/bottom
- D = Position inquiry VE stop blade, damper retracted: yes/no

Stop gate VE 5/D-1000-E, VE 5/OCD-1000-E

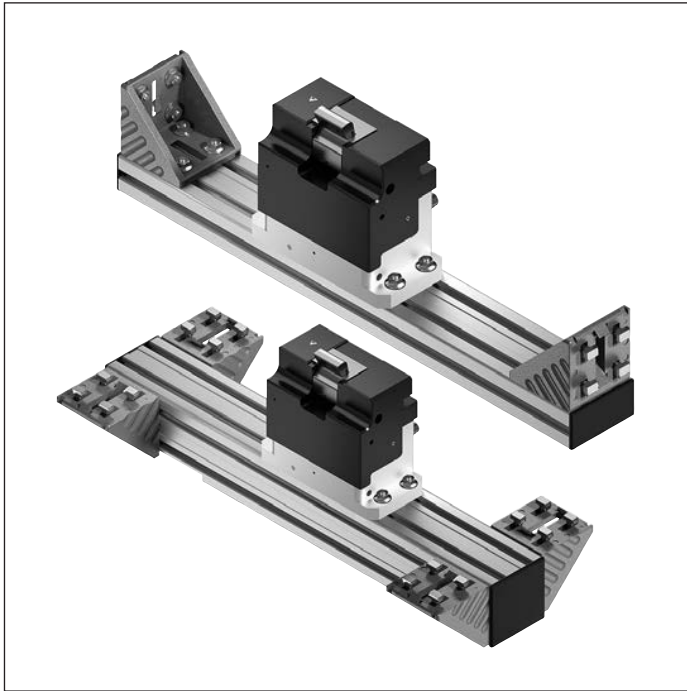

Use

- ▶ Electrical stop gate for the set-up of plants without pneumatic system
- ▶ Dampened stopping of an accumulating workpiece pallet at the defined workpiece pallet stop surface and for workpiece pallet separation
- ▶ Can be combined with WT 5

Version

- ▶ Little installation work as there is no pneumatic system
- ▶ Low noise development
- ▶ Loading only in the direction of transport
- ▶ No spring return, the stop blade of the stop gate is reset or put up by means of a step motor
- ▶ Hydraulic damping, not adjustable
- ▶ Transportation control

Notice: Cannot be combined with ST 5/XH-FR, AS 5/XH-FR, ST 5/H-FR and AS 5/H-FR.

Scope of delivery

- ▶ Incl. fastening material for assembly on conveyor section
- ▶ Electric push-in fitting, 5-pole

Required accessories

- ▶ Actuator and sensor system cables common in the market (5-pole)

Condition on delivery

- ▶ Not assembled

Material

- ▶ Housing: Aluminum; hard anodized
- ▶ Stop: Steel; hardened

Technical data

Material number		3 842 998 924	3 842 998 925
Properties			
Operating temperature	T	°C	+5 ... +60
ESD			yes
Cycle Time		s	5

Ordering information

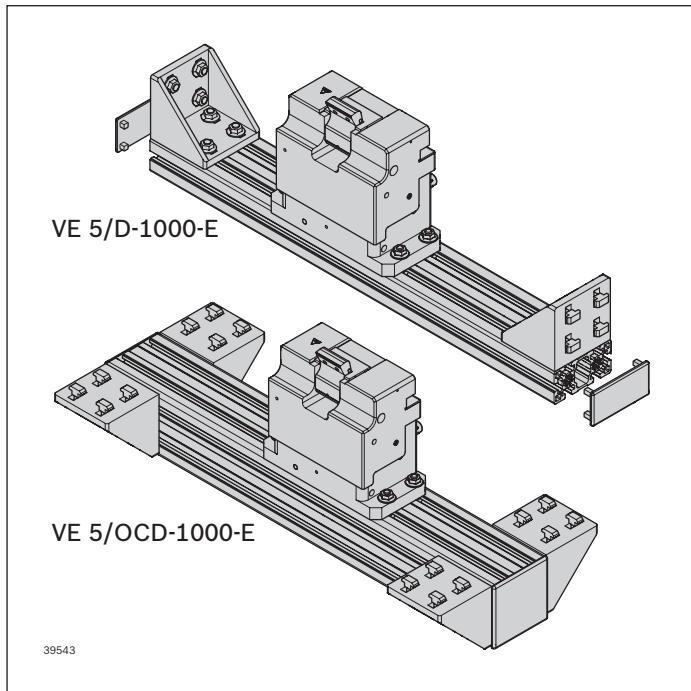

Stop gate VE 5/D-1000-E

b (mm)	Material number
455; 650; 845; 1040	3 842 998 924
	b = ... mm

b = Track width

Stop gate VE 5/OCD-1000-E

b (mm)	AO	Material number
400 ... 1500	1; 2; 3; 4	3 842 998 925
		b = ... mm

b = Track width

AO = Installation location

- 1: ST 5/OC; AS 5/OC; PE 5/OC; PE 5/OC-T
- 2: PE 5/OC; PE 5/OC-T (b = 455, l_T = 455)
- 3: PE 5/OC (b = 455, l_T = 650)
- 4: PE 5/OC-T (l_T = 455, b = 650)

Permissible impact force per WT

m_{WT} (kg)	v_N¹⁾ (m/min)
50 ... 1000	6 ... 9
50 ... 900	12
50 ... 800	15
50 ... 700	18

¹⁾ Conveyor speed

Trap guard

Material number
3 842 552 672

Dimensions

Stop gate VE 5/D-1000-E

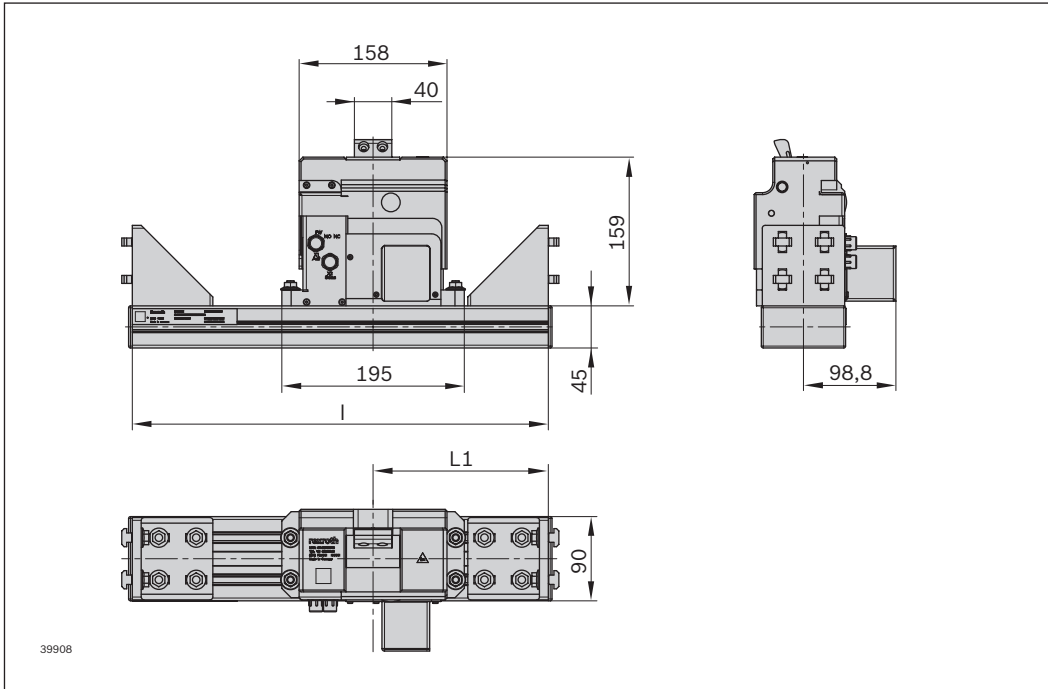

VE 5/OCD-1000-E

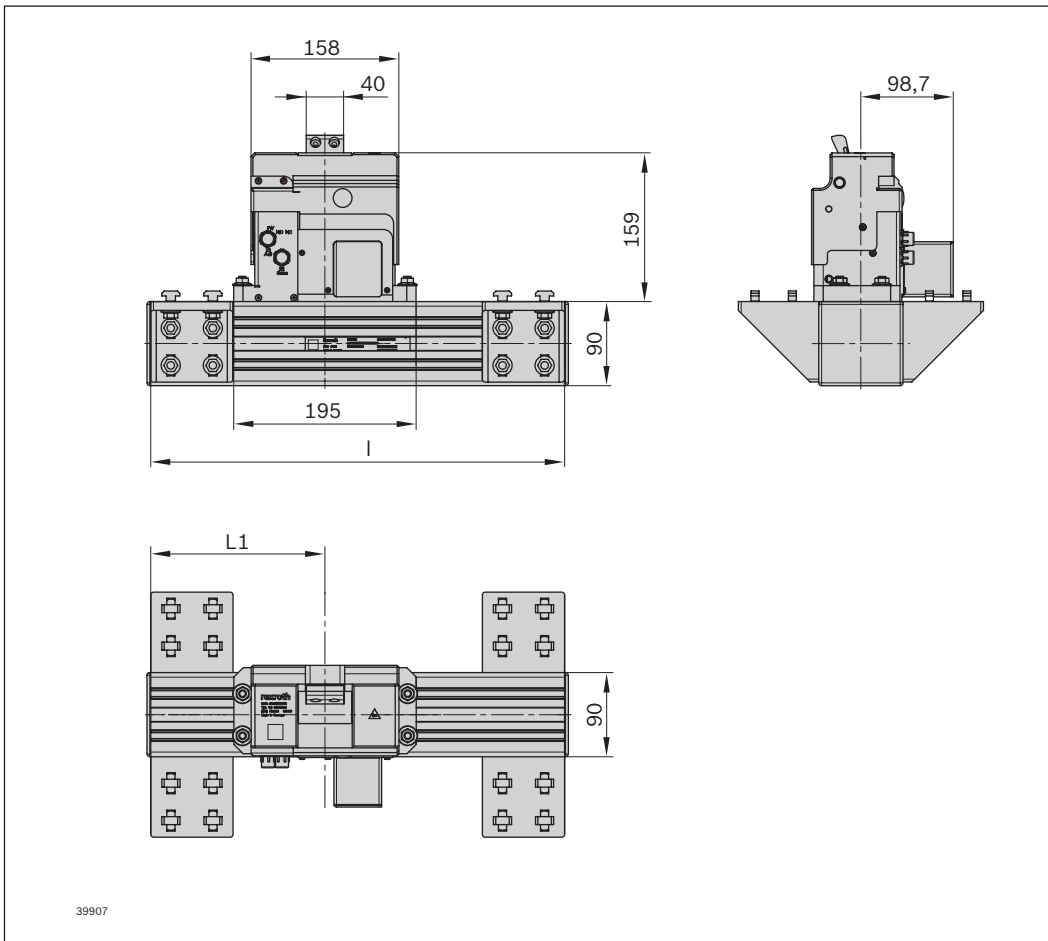

Clamping holder for sensors



Clamping holder for sensors

Use

- ▶ Clamping holder for sensor \varnothing 12 mm, for screwing onto the stop gate

Material

- ▶ Brass; nickel-plated

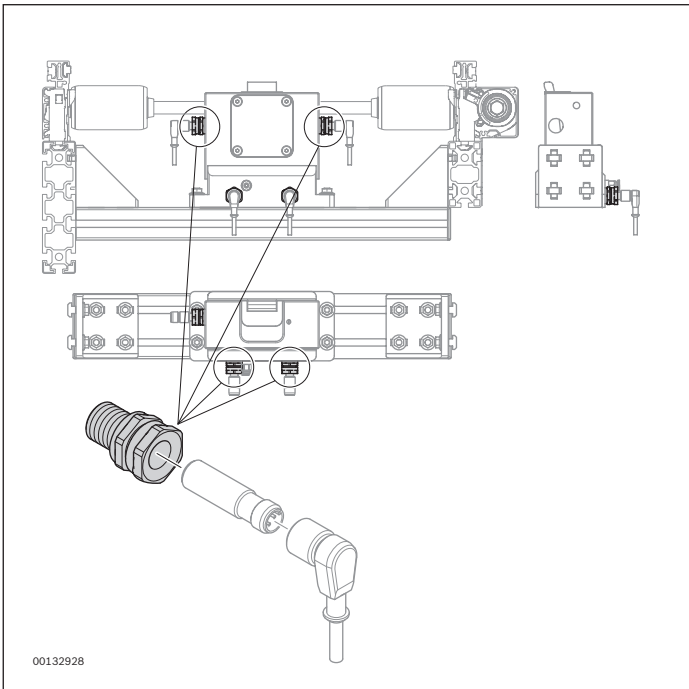

Clamping holder

		Material number
	1	3 842 545 974

Sensors with push-in fitting M8x1, M12x1 and M18x1



Use

- ▶ Detection of the position of a workpiece pallet, position inquiry in respect of lift/transverse units and positioning units

Required accessories

- ▶ Switch bracket SH 2/U-H, see page 9-22
- ▶ Assembly kit for switch bracket, see page 9-24
- ▶ Clamping holder for sensor, see page 9-18

Version

Material number		3842549811	3842549813 ¹⁾	3842551761	3842549814	3842557633 ¹⁾	3842558990 ¹⁾	3842545972
Properties								
Protection class		IP 67	IP 67	IP 68	IP 67	IP 68	IP 68	IP 67
Material		Housing: CuZn; nickel-free coating Active surface: LCP	Housing: CuZn; nickel-free coating Active surface: LCP	Housing: Stainless steel; non-rusting Active surface: PBT	Housing: CuZn; nickel-free coating Active surface: LCP	Housing: CuZn; nickel-free coating Active surface: LCP	Housing: CuZn; nickel-free coating Active surface: LCP	Housing: CuZn; nickel-free coating Active surface: LCP
Max. operating temperature	T °C	-25 ... +70	-25 ... +70	-25 ... +70	-25 ... +70	-25 ... +70	-25 ... +70	-15 ... +70
Dimensions	mm	M12x44	M12x44	M8x30	M12x45	M12x45	M12x60	M18x65
Length	L mm	44	44	30	45	45	60	65
Push-in fitting		M8x1	M8x1	M8x1	M12x1	M12x1	M12x1	M18x1
Additional information								
Rated switching distance	S _N mm	4	8	2	4	8	8	13
Switching frequency	Hz	2500	800	1500	300	500	1000	800
Operating current	mA	200	200	200	200	200	200	200
Mechanical installation		Flush	Not flush	Flush	Flush	Not flush	Not flush	Not flush
Function display		LED	LED	LED	LED	LED	LED	LED
Switching output		PNP	PNP	PNP	PNP	PNP	PNP	PNP
Switching function		Normally open (NO)	Normally open (NO)	Normally open (NO)	Normally open (NO)	Normally open (NO)	Normally open (NO)	Normally open (NO)
Operating voltage	V DC	10 ... 30	10 ... 30	10 ... 30	10 ... 30	10 ... 30	10 ... 30	10 ... 30
Approvals		CE, UL, CSA	CE, UL, CSA	cULus, CE, EAC	cULus, CE, EAC	cULus, CE, EAC	cULus, CE, EAC	cULus, CE, EAC
Conformity with standards		IEC 60947-5-2	IEC 60947-5-2	IEC 60947-5-2	IEC 60947-5-2	IEC 60947-5-2	IEC 60947-5-2	IEC 60947-5-2

¹⁾ Not suitable for position inquiry in respect of stop gates

Ordering information

Circuit diagram M8x1

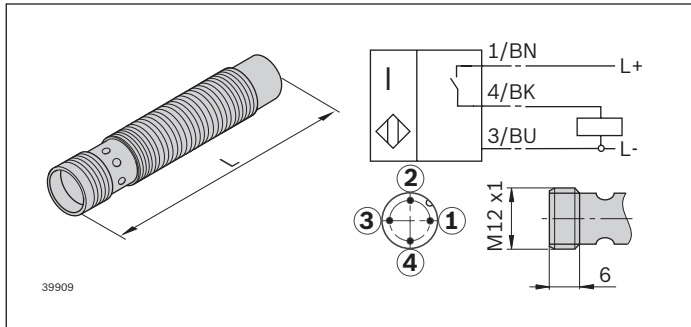

Plug connection	Length (mm)	Material number
M8x1	44	3 842 549 811
	44	3 842 549 813
	30	3 842 551 761

Circuit diagram M12x1

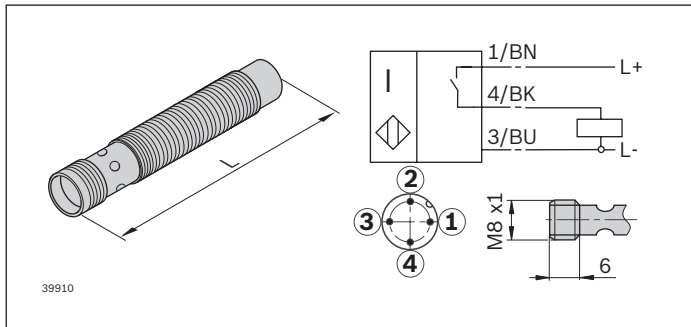

Plug connection	Length (mm)	Material number
M12x1	45	3 842 549 814
	45	3 842 557 663
	60	3 842 558 990

Circuit diagram M18x1

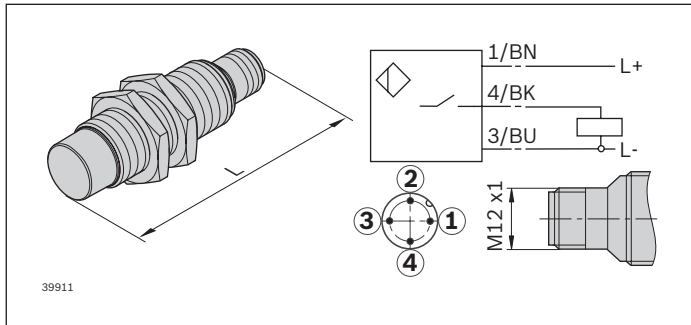

Plug connection	Length (mm)	Material number
M18x1	65	3 842 545 972

Sensor application matrix

		Diameter with push-in fitting		Sensor	
		M12 with M12		3842549814 3842557633 3842558990	
		M18 with M12		3842545972	
		M8 with M8		3842549811 3842549813 3842551761	
Position inquiry					
Stop gate VE 5					
Lift	VE 5/200	3 842 998 518			x
Lift	VE 5/OC-200	3 842 998 577			x
Stop blade and lift	VE 5/D-300	3 842 998 517			x
Stop blade and lift	VE 5/OCD-300	3 842 998 578			x
Stop blade and lift	VE 5/D-1000	3 842 998 805			x
Stop blade and lift	VE 5/OCD-1000	3 842 998 806			x
Stop blade	VE 5/D-301	3 842 998 079		x	
Stop blade	VE 5/OCD-301	3 842 998 080		x	
Lift	VE 5/D-301	3 842 998 079			
Lift	VE 5/OCD-301	3 842 998 080			Sensor on request
Positioning unit PE 5					
	PE 5	3 842 998 786			
	PE 5/T	3 842 998 177			
	PE 5/OC	3 842 998 178			
	PE 5/OC-T	3 842 998 804			
	PE 5/L	3 842 998 048			x
	PE 5/LT	3 842 998 049			x
Lift transverse unit HQ 5					
Lift	HQ 5/XH	3 842 998 929			x
Lift	HQ 5/H	3 842 998 928			x
WT in position	HQ 5/XH	3 842 998 929			x
WT in position	HQ 5/H	3 842 998 928			x
Diverter DI 5					
	DI 5/XH	3 842 998 529			
	DI 5/H	3 842 998 528			
	DI 5/XH-3W	3 842 998 807			Sensor on request
	DI 5/H-3W	3 842 998 808			
Rotary unit DE 5					
	DE 5	3 842 998 863	x	x	
	DE 5/FR	3 842 998 862	x	x	
	DE 5/OC	3 842 998 864	x	x	
WT position inquiry					
	SH 2/U-H	3 842 537 289		x	
	SH 2/U-H	3 842 537 289			
WT in position	in PE5 b>455 (3 842 998 786)				x

Switch bracket SH 2/U-H



Use

- ▶ Fastening for a M12x1 sensor for workpiece pallet position sensing from below and for position inquiry at HQ 5... and PE 5...
- ▶ Especially sturdy metal design

Version

- ▶ Die-cast aluminum
- ▶ Integrated stop for 12 mm sensor

Mounting location

- ▶ On the assembly kit for the switch bracket

Scope of delivery

- ▶ Incl. fastening material for assembly

Required accessories

- ▶ Assembly kit for switch bracket SH 2/U-H, see page 9-24
- ▶ Sensor M12x1 with $S_N \geq 4$ mm switching distance, see page 9-19

Ordering information

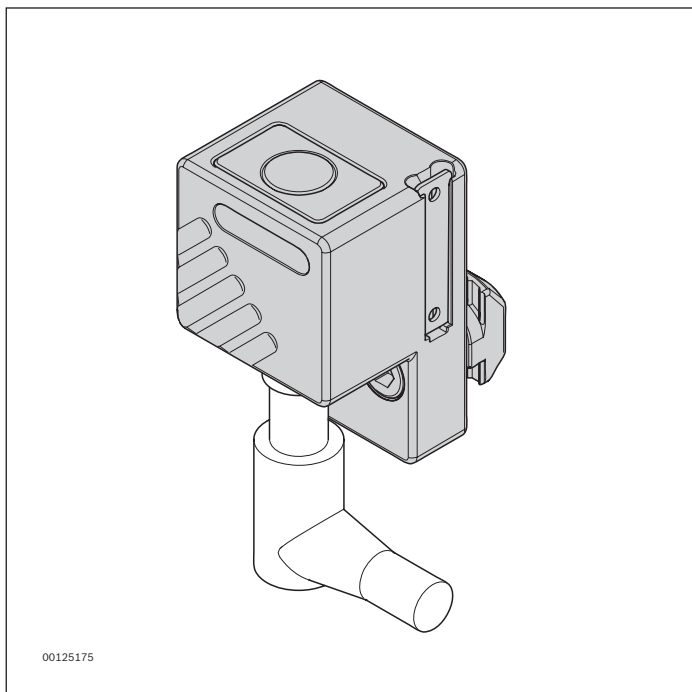

00125175

Switch bracket SH 2/U-H

Material number
3 842 537 289

Dimensions

Switch bracket SH 2/U-H

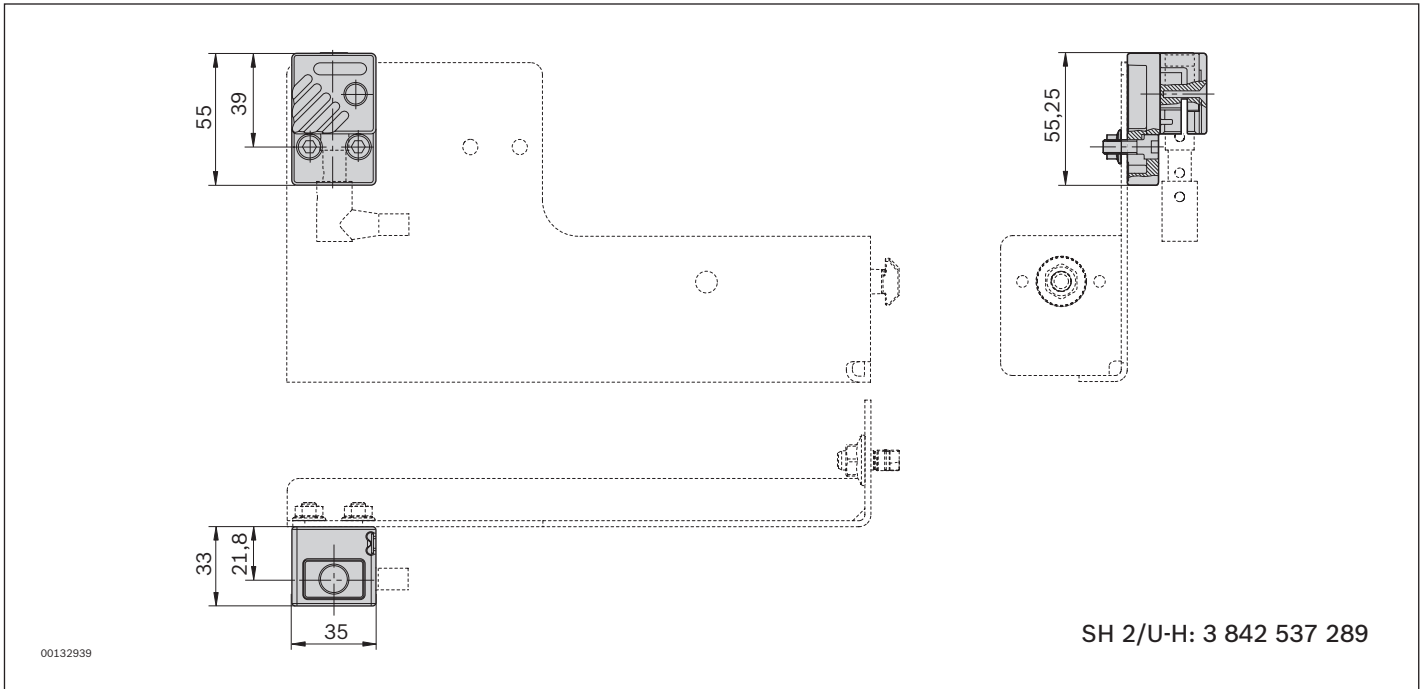

Assembly kit for switch bracket SH 2/U-H



Use

- ▶ Holding plate to bring the switch bracket into the correct inquiry position

Version

- ▶ Centering lugs for pre-positioning and fast assembly

Scope of delivery

- ▶ Incl. fastening material for assembly
- ▶ ST 5/H; ST 5/XH; ST 5/OC: Incl. 45x90 bracket for reinforcement as needed

Condition on delivery

- ▶ Not assembled

Required accessories

- ▶ Switch bracket SH 2/U-H, see page 9-22
- ▶ Sensor M12x1 with $S_N \geq 8$ mm switching distance, see page 9-19

	b (mm)	Mounting location	Material number
Assembly kit SH 2/U-H on conveyor unit ST 5/XH, ST 5/H	455; 650; 845; 1040	ST 5/XH, ST 5/H	3 842 545 134
Assembly kit SH 2/U-H on conveyor unit ST 5/OC	455; 650; 845	ST 5/OC	3 842 545 533
Assembly kit SH 2/U-H on positioning unit PE 5	*	PE 5, HQ 5	3 842 545 132

b = Track width

* Not required for b = 455 mm (fitted to stop gate without assembly kit)



Identification systems

Identification systems	10-2
Assembly kit for identification system ID 200 in the longitudinal conveyor	10-3
Assembly kit for identification system ID 200 in Open Center sections	10-4
Kit for installation in workpiece pallet WT 5	10-5

Identification systems



Identification and data tag systems are used to control numerous production and transport systems in assembly technology applications.

Data related to objects is the basis for

- ▶ Targeted control of processes and processing steps
- ▶ Infeeding or outfeeding workpiece pallets according to type or variant when manufacturing product variants on flexible assembly systems.

You can find our current range of identification and data tag systems in the RFID systems catalog.

Required accessories

- ▶ Communication module ID 200/C..., see RFID Systems catalog
- ▶ Antenna ID 200/A..., see RFID Systems catalog
- ▶ Mobile data tag MDT 3/2K-H (3 842 410 102), see RFID Systems catalog
- ▶ Cables, see RFID Systems catalog
- ▶ Assembly kit for identification system read/write heads, see RFID Systems catalog

RFID Systems catalog

	Material number
DE	3 842 541 003
EN	3 842 541 004
FR	3 842 541 005
IT	3 842 541 006

Assembly kit for identification system ID 200 in the longitudinal conveyor

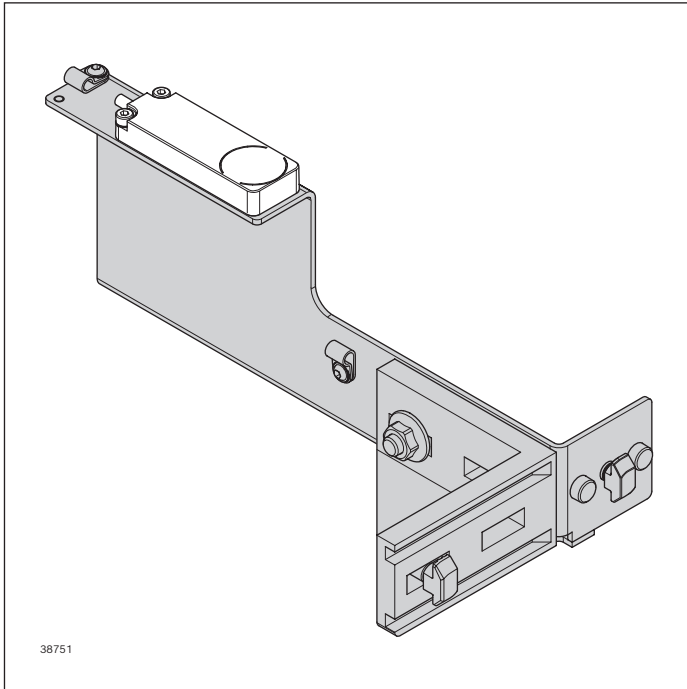

Use

- ▶ Fastening of the write/read head ID 200/-... in the longitudinal conveyor

Notice: Identification system ID 200 in transverse conveyor on request.

Version

- ▶ Centering lugs for pre-positioning and fast assembly

Mounting location

- ▶ On the section profile

Scope of delivery

- ▶ Incl. fastening material for assembly and a 45x90 bracket for reinforcement as needed

Condition on delivery

- ▶ Not assembled

Required accessories

- ▶ Communication module ID 200/C..., see RFID Systems catalog
- ▶ Antenna ID 200/A..., see RFID Systems catalog
- ▶ Mobile data tag MDT 3/2K-H (3 842 410 102), see RFID Systems catalog
- ▶ Cables, see RFID Systems catalog

Assembly kit for identification system ID 200, longitudinal conveyor

b (mm)	Material number
455; 650; 845	3 842 545 144

b = Track width

Assembly kit for identification system ID 200 in Open Center sections

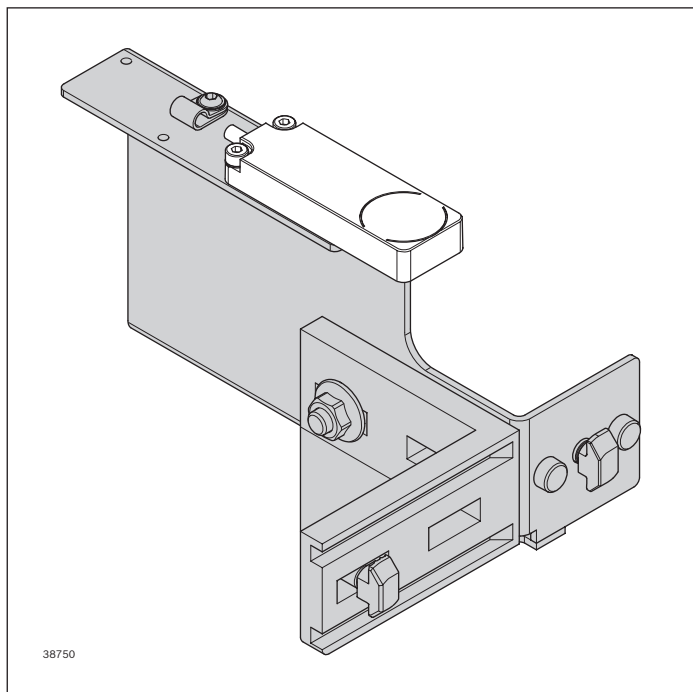

Use

- ▶ Fastening of the write/read head ID 200/-... in the longitudinal conveyor

Notice: Identification system ID 200 in transverse conveyor on request.

Version

- ▶ Centering lugs for pre-positioning and fast assembly

Mounting location

- ▶ On the section profile

Scope of delivery

- ▶ Incl. fastening material for assembly and a 45x90 bracket for reinforcement as needed

Condition on delivery

- ▶ Not assembled

Required accessories

- ▶ Communication module ID 200/C..., see RFID Systems catalog
- ▶ Antenna ID 200/A..., see RFID Systems catalog
- ▶ Mobile data tag MDT 3/2K-H (3 842 410 102), see RFID Systems catalog
- ▶ Cables, see RFID Systems catalog

Assembly kit for identification system ID 200, longitudinal conveyor

b (mm)	Material number
455; 650; 845	3 842 545 539

b = Track width

Kit for installation in workpiece pallet WT 5

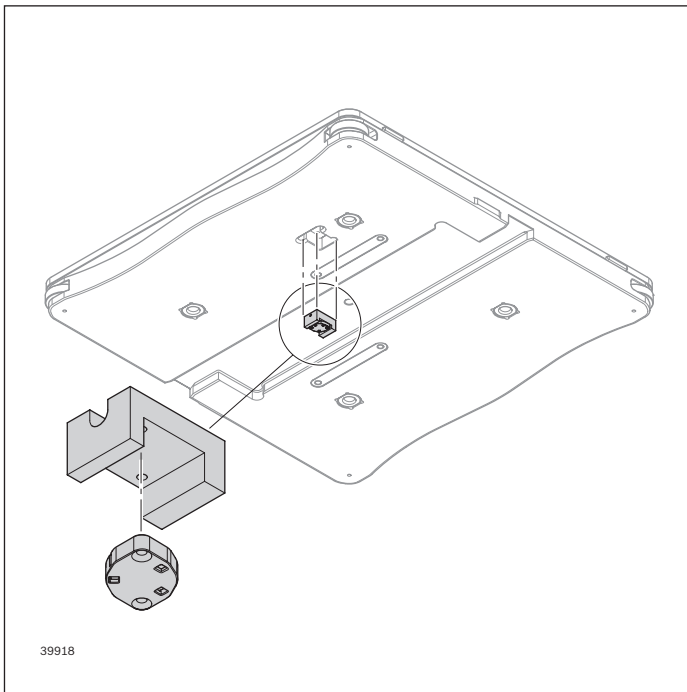

Use

- ▶ For installation of the data tag in workpiece pallet WT 5

Mounting location

- ▶ On workpiece pallet WT 5

Scope of delivery

- ▶ Incl. fastening material for mounting the kit

Condition on delivery

- ▶ Not assembled

Required accessories

- ▶ For data tag, see RFID systems catalog

Kit for identification system ID 200

Material number
3 842 545 450

10-6 **TS 5 5.0** | Identification systems
Kit for installation in workpiece pallet WT 5



Tools

Disassembly tool

11-2

Disassembly tool



Use

- To gently remove the covers (on the king shaft and passive side).

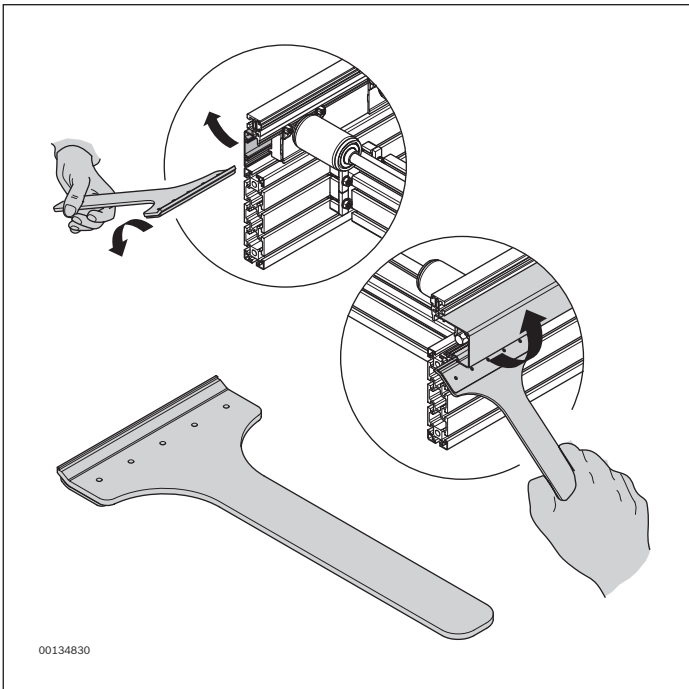

00134830

Product description	Material number
Disassembly tool	3 842 545 836



MTpro – Planning software

MTpro – Planning software

12-3

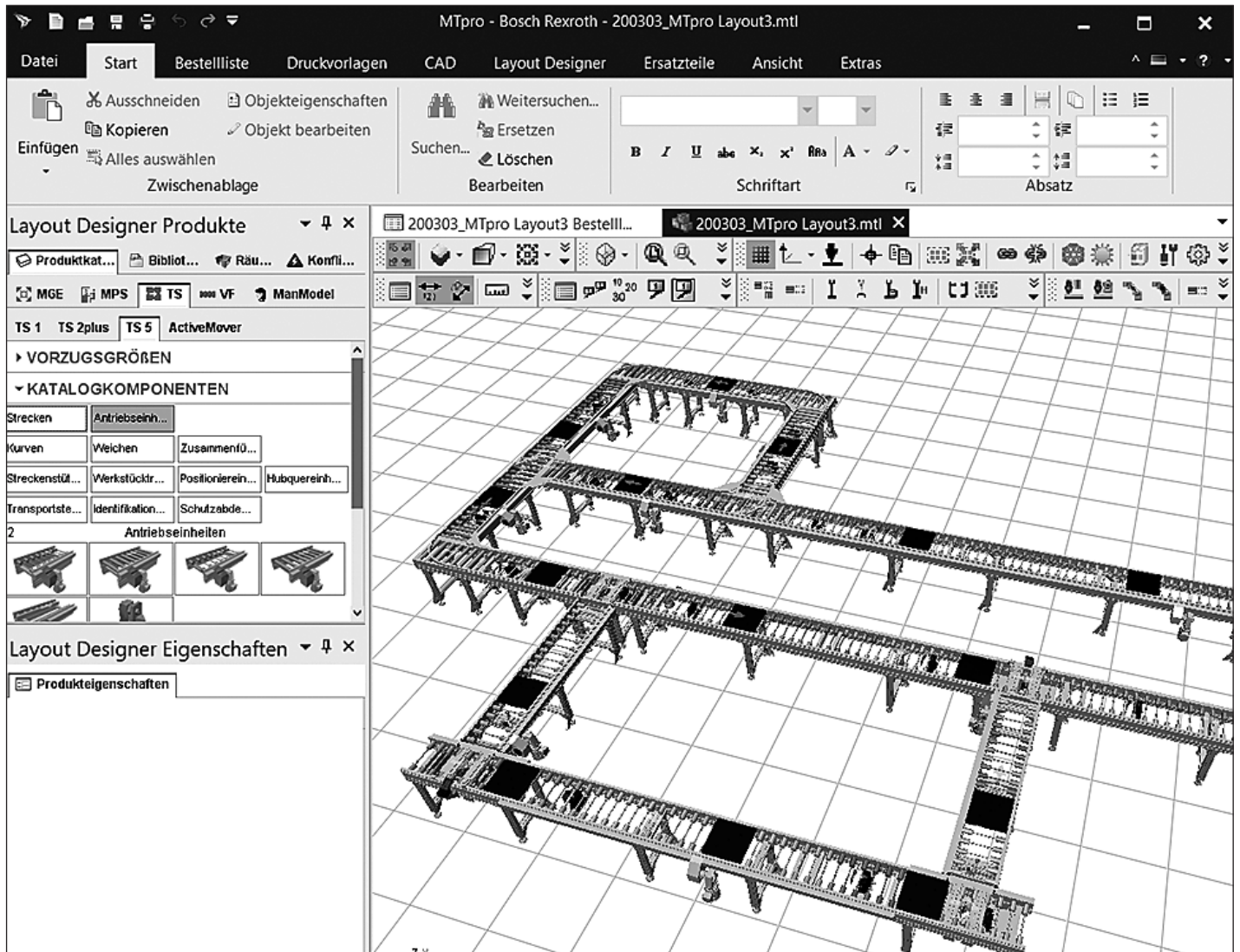

MTpro – Planning software

MTpro is a software program used for planning assembly systems. It assists you from selection to configuration and ordering of the Rexroth products. The program offers the following functions and full content in seven languages (en/de/fr/es/it/ja/zh):

Layout Designer for planning and designing complete frames and conveyor systems

- ▶ Simple design using the drag & drop and snap functions without a CAD system
- ▶ Design logic for automatic configuration and assembly adaptation
- ▶ Automatic order list generation of all small parts and accessories
- ▶ Export of 3D volume models
- ▶ Library for saving and reusing your own modules and layouts

Product information

- ▶ Technical data
- ▶ Catalog data sheets
- ▶ Assembly instructions
- ▶ Spare parts lists and drawings

Configuration and calculation

- ▶ Product configuration and generation of ordering information
- ▶ Issuing of order lists in user-specific presentations
- ▶ Direct connection to Rexroth eShop
- ▶ Quick & Easy profile configuration and drafting
- ▶ Other design and calculation programs

CAD library

- ▶ Configurable CAD models
- ▶ Memories in standard formats
- ▶ Direct integration into all common CAD systems

System requirements

- ▶ Windows from version 10 onwards
- ▶ USB data tag in vCard format
- ▶ At least 6 GB of free hard drive space
- ▶ Adobe Reader from version 10 onwards
- ▶ Internet access for Layout Designer licensing and automatic updates

rexroth
A Bosch Company

Engineering Software

MTpro 5.0

Bosch Rexroth AG
Postfach 30 02 07
70442 Stuttgart
mtpro@boschrexroth.de
www.boschrexroth.com

rexroth
A Bosch Company

Installation information
www.boschrexroth.com/mtpro

© Bosch Rexroth AG 2019
Subject to modifications!

3 842 539 057 (2019-10)
DE+EN+FR+IT+ES+JA+ZH

Material number 3 842 539 057 for ordering
of a USB data tag or via download at:
www.boschrexroth.com/mtpro

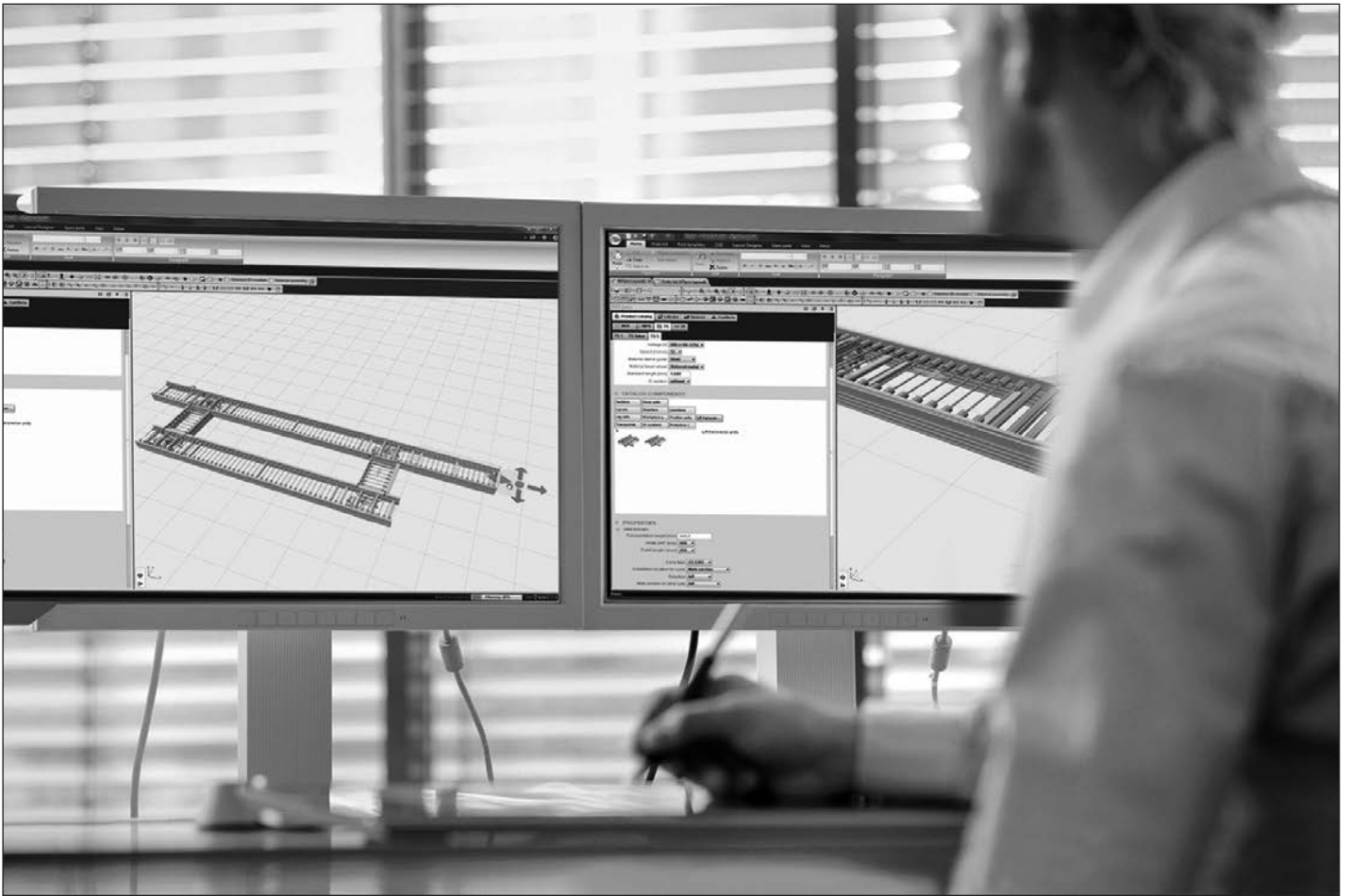

Technical data

System specifications	13-2
Drive data	13-6
Motor data	13-7
Transport and nominal speed v_N	13-9
Motor connection	13-10
Frequency converter (FU)	13-11
Ordering parameters for SEW motors	13-13
Conversion table for metric/imperial dimensions	13-15
Function plans	13-16
Compressed air consumption	13-29

System specifications

Application

The Rexroth transfer systems all form a program of fine-tuned mechanical components that are used to convey, separate, and position workpiece pallets. With these components, you can create almost any system layout you need.

The systems are primarily used to convey workpieces (on Rexroth workpiece pallets) to and from manual or automatic work stations on an assembly line.

Planning

Transfer system planning, setup, initial start-up and maintenance should only be done by trained personnel. Rexroth offers training courses for this.

Scope of delivery – small parts

The sensors, pneumatic valves, and electrical and pneumatic installation material that are necessary for operation are usually not included in the scope of delivery. These parts are only preassembled if they guarantee special functional safety or if installing them at a later point would require too much effort.

Please note the references for the required flow control valves and check valves in the pneumatic switching plan (listed in the assembly and operating manual) must be followed.

Notices

Examples

Installation references, pneumatic switching plans and typical function processes are described in the catalogs and assembly instructions. These must be followed when setting up and commissioning the system.

CE identification, responsibility

Components that fall under the EC Machinery Directive are delivered with the corresponding manufacturer's

declaration. Overall responsibility for system safety (declaration of conformity, CE identification) lies with the system builder. The references in the assembly instructions and in the Instructions for Employees on Safety – 3 842 527 147 must be followed.

Materials used

The materials used in the components are primarily:

- ▶ Non-rusting steel or steel with a corrosion protected surface,
- ▶ Brass,
- ▶ Cast or malleable aluminum alloys,
- ▶ Polyurethane, polyamide, in some cases with additives to improve electrical and mechanical characteristics, and UHMW polyethylene.
- ▶ NBR or Viton for elastic seals.

Media resistance

Resistant to many common media used in production such as water, mineral oil, grease, and detergents. Contact your Rexroth representative if you have any doubts about resistance to specific chemicals, e.g. test oil, doped oils, aggressive detergents, solvents, or brake fluid. Avoid prolonged contact with highly reactive acidic or alkaline materials.

Contamination

Wear may increase dramatically if the system is contaminated, particularly with abrasive media from the surrounding area such as sand and silicates from construction, but also due to processes running on the transfer system (e.g. welding beads, pumice dust, glass shards, shavings, or lost parts, etc.). In such cases, maintenance intervals must be substantially shortened.

Such cases require special attention when planning the system and adjusting the maintenance intervals.

Functional safety

Resistance to media and contamination does not mean that functional safety is guaranteed in every case.

- ▶ Liquids that thicken on evaporation and are highly viscous or adhesive (sticky) could lead to a disruption in function.
- ▶ Media with lubricating properties may reduce the drive power transferred by friction if they are carried over onto systems with rollers.

Environmental sustainability, recycling

The materials used are environmentally friendly. They can be recycled or reused (components may have to be processed and replaced). Recyclability is ensured by the selection of materials and the ability to take the components apart.

Pneumatic connection data

Oiled or non-oiled, filtered, dry compressed air.
Operating pressure 6 bar. Performance data is for an operating pressure of 6 bar.

Maintenance

The TS components require very little maintenance. If maintenance-free operation cannot be achieved at an economically justifiable cost, maintenance instructions are specified in the operating manual.

Wear

Wear is caused by the basic principle of this system and cannot be avoided. Constructive measures and selection of the proper materials will help functional safety last for the service life of the system. However, wear depends on the operating, maintenance, and ambient conditions of the system and the location (resistance, contamination).

Measures to reduce wear

The following measures reduce wear and the friction caused by it:

- ▶ Switch off conveyor sections when the system is not running, e.g. during breaks, overnight, on the weekend.
- ▶ Only select conveyor section speeds that correspond with the particular function.
- ▶ Minimize the weight of the workpiece pallet – do not overload workpiece supports with material.
- ▶ Avoid unnecessary accumulation sections, e.g. by reducing the WT number
- ▶ Switch off accumulation sections carrying heavy workpiece pallets if WT transport is not necessary.
- ▶ Very important: Avoid contamination by abrasive media or reduce contamination through regular cleaning.

Load specifications

Permitted loads apply for conveyor sections only under the condition that workpiece pallets with the maximum permitted weight have accumulated.

Accumulation operation is not permitted at curves, diverters, junctions, or the positioning unit.

Wear and conveyor speed

Nominal data for the permitted workpiece pallet weight describe operation with standard speeds and normal operating conditions.

Wear on the workpiece pallet wear pads and the conveyor medium will not influence system function throughout the service life.

Loading the workpiece pallet, gravity center position

Concentric load with a low center of gravity is generally preferable. Incorrect load distribution with a high and/or eccentric gravity center on the WT may have a negative influence on smooth running and safety. Pay attention when arranging supports and workpieces on the workpiece pallet that the center of gravity of the loaded WT is within the area $1/3$ of the length or width from the center of the WT. The maximum height of the center of gravity over the transport level should not exceed $1/2$ of the WT length or width.

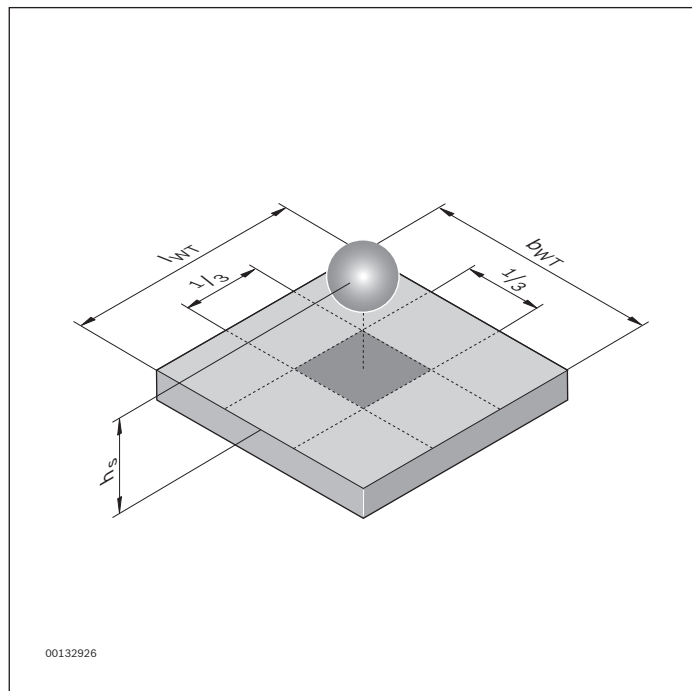

Loading the workpiece pallet, combination of empty and loaded workpiece pallet

When setting up and testing the modular units, the workpiece pallets should not all have the same weight on the conveyor sections, i.e. full and empty pallets should all come through the circuit. Extreme differences in weight may require special measures to avoid functional disruptions. This applies, e.g. to the permitted accumulation length before stop gates, for the function of dampers and dampened stop gates. Function is usually not limited if the weight ratio is 2:1 between heavy workpiece pallets (loaded with a workpiece) and light workpiece pallets (empty).

Loading the workpiece pallet, minimum weights

The minimum weight of the workpiece pallet is generally not relevant. In special cases, depending on the marginal conditions, an application-specific minimum weight may be required for safe and continuous transport. This can occur, for example, if switching elements have to be manually operated (e.g. on a rocker), or if a light WT does not run smoothly when changing directions. In such unusual cases, additional weight should be added when designing the workpiece support.

Overloading

Overloading the conveyor section can cause the conveyor medium to fail and motors and gears to fail prematurely. When overloading of pneumatic components occurs, function cannot be guaranteed.

Weight of the workpiece pallet, maximum weights

The permissible total weight of the workpiece carrier for the drive module and the conveyor unit depends on the length of the workpiece pallet l_{WT} , the roller spacing p and the roller type. The carrying force per roller is 50 kg, and the workpiece pallet must always be on at least 3 rollers. Alternative load limits must be observed for curves, junctions, diverters, lift transverse units, positioning units and rotary units, see the following graphic.

Permissible workpiece pallet weights on the modular units at medium load and speed below 9 m/min*

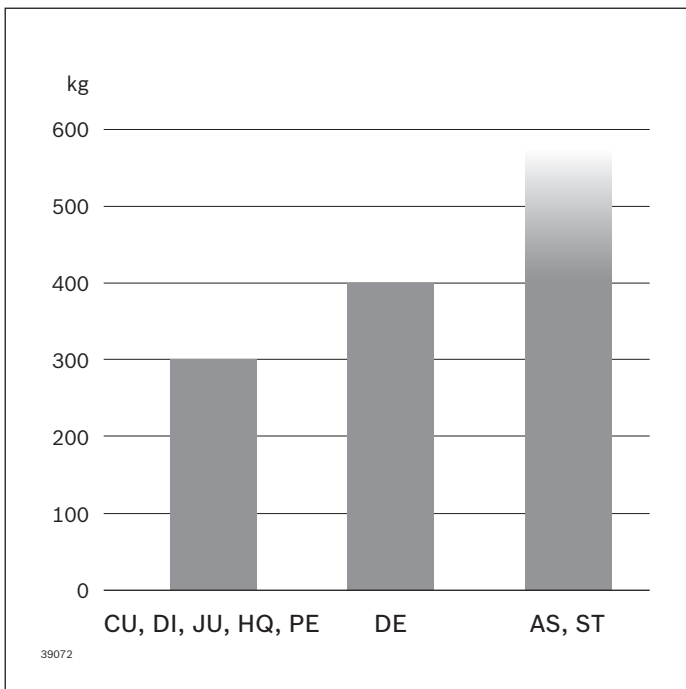

Transport speed, dynamic influences

When the transport speed increases bumps when changing directions and the rebound force on the stop gates also increase. This may require longer damping periods or shock absorbers before the next movement.

* The permissible load depends on the speed

Drive data

Definition of the basic principles of motor specifications

The specified performances, torques and revolutions per minute are rounded values and apply to:

- Operating time/day = 8 h (100% duty cycle)
- Uniform operation (continual), no, or very light, impacts in a rotational direction at 10 switching cycles/hour
- Installation positions and designs described in the catalog
- Maintenance-free gears with life-long lubrication,
- Ambient operating temperature 0 ... 60 °C. Gear unit with life-long lubrication for ambient operating temperature ≤ 0 °C available on request
- Protection class IP 55
- $f_{\text{mains}} = 50$ Hz constant
- $T_{\text{U}} = 20$ °C for gears
40 °C for motors

- Installation altitude ≤ 1000 m above sea level
- If the drive is overloaded, the service life is reduced.
Overload by 10%: = 75% service life
Overload by 20%: = 50% service life
- The gear motor (GM = 1) corresponds to the operating mode S1 (continuous operation)

In the case of other operating conditions, the achievable values may differ from those stated.

In the case of extreme operating conditions, please consult your distribution partner.

Motor data

Electrical connection requirements:

Connection to a 3-phase, 5-wire system (L1, L2, L3, N, PE), a connection diagram is included in the terminal box. All motors are equipped with a thermal contact*), which must be connected to an overload switch-off.

All of the motors comply with protection class IP 55.

*) Bi-metal thermal contact, opening, tripping at $150\text{ °C} \pm 5\text{ °C}$.

Motor for push-on gearbox (with plug AT=S)



Gear motor (with plug AT=S)

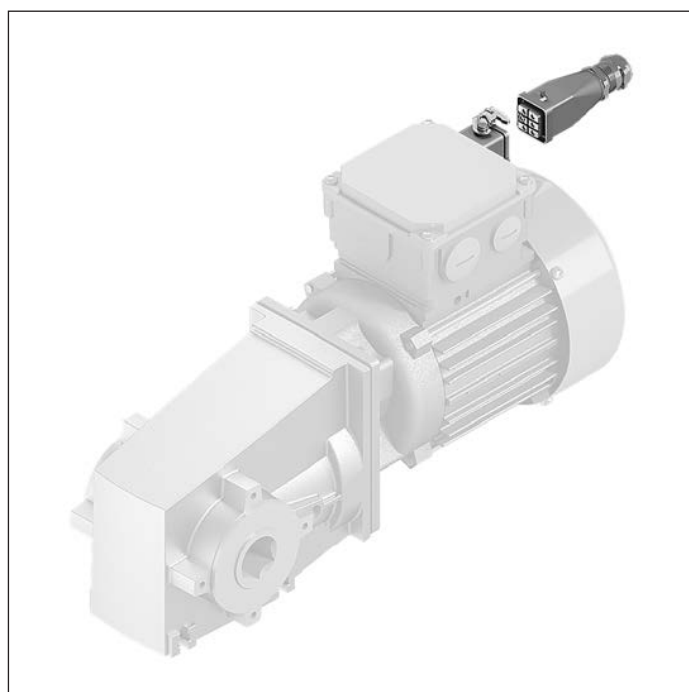

Country classification

	Europe	Switzerland	USA	Canada	Brazil	Australia	New Zealand	South Korea	China	India
Line voltage (3x....)	400 V	400 V	480 V ¹⁾	480 V ¹⁾ 575 V	220 V 380 V ³⁾ 440 V ¹⁾	400 V 415 V ²⁾	400 V 415 V ²⁾	220 V 380 V ³⁾ 440 V ¹⁾	380 V ²⁾	415 V ²⁾
Line voltage tolerance	±10%	±10%	±10%	±10%	±10%	±5%	±5%			±5%
Line frequency	50 Hz	50 Hz	60 Hz	60 Hz	60 Hz	50 Hz	50 Hz	60 Hz	50 Hz	50 Hz

¹⁾ ~ 460 V / 60 Hz

²⁾ ~ 400 V / 50 Hz

³⁾ ~ 400 V / 60 Hz

Motor data

Performance data

Notice: Values are typical. Subject to change. See motor type plate for official data.
Please note the country assignment.

Voltage class	A		B	D
Circuit	Δ		Y	Y
Voltage U at f = 50 Hz	200 V ±10%		400 V +10...-12%	
Voltage U at f = 60 Hz	220 V ±10%	400 V ±10%	460 V +10...-12%	575 V ±10%

Motor type	IE3	Current consumption at rated power				Power factor cos φ	Power output at	
		I _N (A)	I _N (A)	I _N (A)	I _N (A)		(50 Hz) P (kW)	(60 Hz) P (kW)
524	x	0.65	0.35	0.32	0.24	0.6	0.09	0.1
624	x	1.15	0.65	0.55	0.45	0.66	0.18	0.22
634	x	1.65	0.9	0.85	0.65	0.6	0.25	0.29
714b	x	1.9	1.1	0.95	0.75	0.73	0.37	0.42
804a	x	3.1	1.8	1.45	1.15	0.65	0.55	0.63
716	x	1.3	0.75	0.6	0.62	0.68	0.18	0.22
734	x	1.9	1.05	0.95	0.72	0.74	0.37	0.42
734a	x	2.5	1.4	1.3	1	0.66	0.45	0.52
714a	x	1.65	0.95	0.85	0.65	0.60	0.25	0.29
716a	x	1.3	0.75	0.6	0.52	0.61	0.18	0.22
718b	x	0.95	0.55	0.48	0.38	0.6	0.12	0.14
814	x	3.1	1.7	1.45	1.1	0.69	0.55	0.63
824	x	4.1	2.25	2	1.6	0.66	0.75	0.86

Suitable for continuous operation, start-stop operation with a duty cycle of up to 70% and frequency converter operation.

Certification for the motor, cable and plug components:

IE3 motors: CE, cURUS, CCC

 Gear motor

3-phase motors

T _u (°C)	P _v / P _N
< 40	1 ¹⁾
45	0.95
50	0.90
55	0.85
60	0.8

¹⁾ Rated motor power (0.37; 0.25; 0.12 kW)

Rated motor power

The ambient operating temperature T_u influences the rated power P_N of the gear motors.

Transport and nominal speed v_N

The transport speed v_N is specified for the rated power and frequencies of 50 Hz or 60 Hz.

The actual values v vary depending on:

- ▶ Tolerance of the standard motors
- ▶ Performance range of the motors
- ▶ Load on the conveyor section

	v_N (m/min)	v (m/min)	n_2 (min ⁻¹)	400 V / 50 Hz		400 V / 60 Hz		P (W)	Type
				P (W)	Type	v (m/min)	n_2 (min ⁻¹)		
AS 5/XH	2*	2.17	11.5	120	718b	2.64	14	120	718b
AS 5/H	4*	4.4	23.3	250	714a	3.46	18.3	250	716a
AS 5/OC	6	5.51	29.2	370	714b	6.61	35	370	714b
	9	9.0	47.7	370	714b	8.38	44.5	370	714b
	12	11.31	60	370	714b	10.8	57.3	370	714b
	15	13.85	73.5	370	714b	16.62	88.2	370	714b
	18	16.96	90	370	714b	16.62	88.2	370	714b
	HQ 5	6 (b = 455 mm)	6.01	46.67	90	30/524	5.69	44.21	100
6 (b = 650/845 mm)		6.01	46.67	180	30/624	5.41	42	220	40/624
9 (b = 455 mm)		9.02	70	90	20/524	9.02	70	100	24/524
9 (b = 650/845 mm)		9.02	70	180	20/624	8.66	67.2	220	25/624
12 (b = 455 mm)		12.02	93.33	90	15/524	10.82	84	100	20/524
12 (b = 650/845 mm)		12.02	93.33	250	15/634	10.82	84	220	20/624

v = Transport speeds at other voltages/frequencies available on request

n_2 = Gear output speed

P = Motor output

* Special technical constraints

AS 5/XH, AS 5/H technical data:

Max. torque limit: 45 Nm (toothed belt) limited

Toothed belt drive gear ratio: 1:1

Flange \varnothing : 75 mm

Drive shaft: SW27

Conveyor rollers \varnothing : 60 mm

Motor connection

Motor connection with plug (AT = 1), circuit diagram

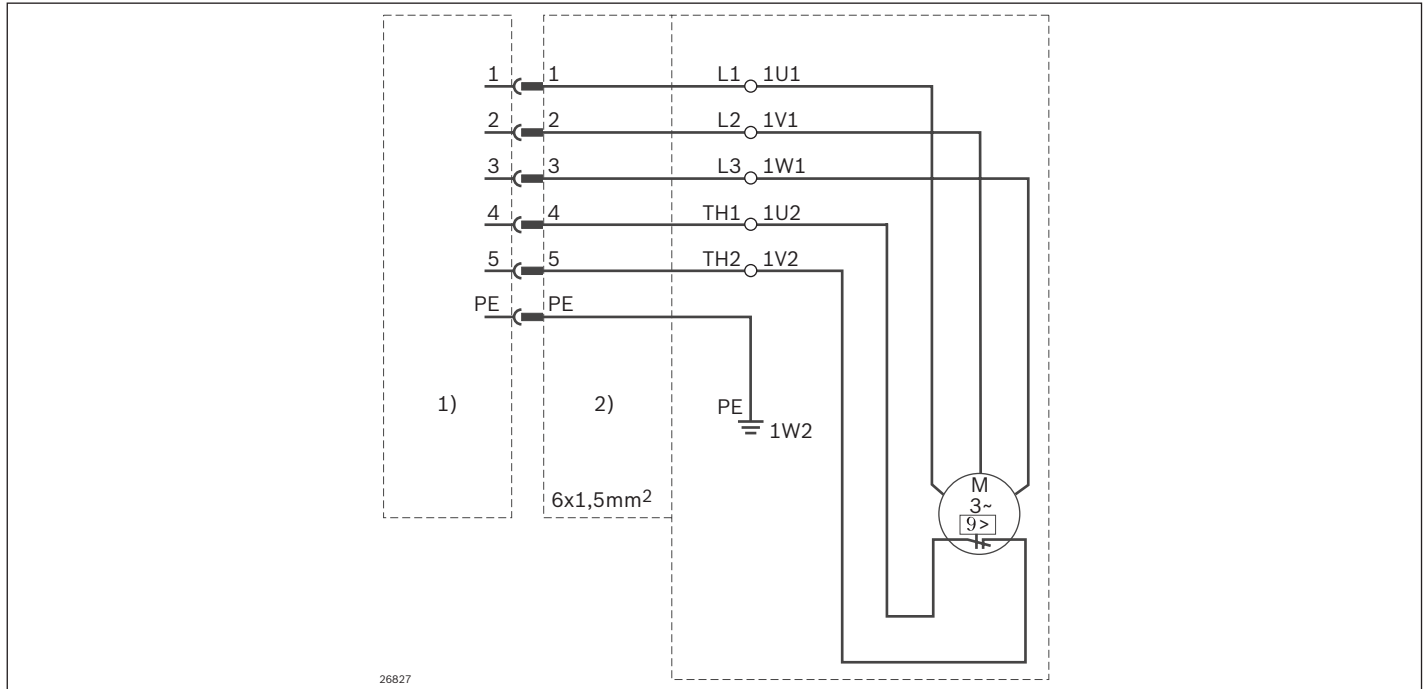

1) Connection cable side

2) Motor side

The push-in fitting consists of UL components.

Connection list

3~ motor connection terminals	Pin no.	Code
U1	1	L1
V1	2	L2
W1	3	L3
TW1	4	Th1
TW2	5	Th2
	PE	PE

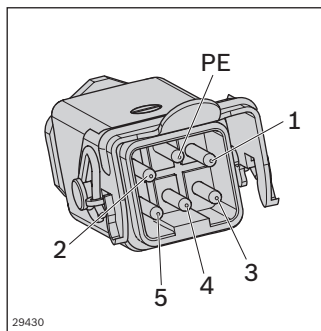

Motor side

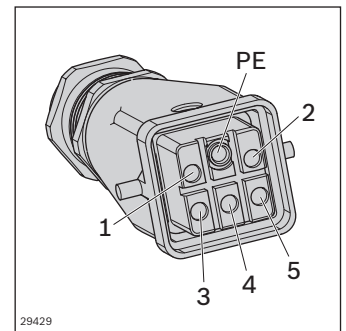

Connection cable side

Frequency converter (FU)

Drive spectrum of motors with frequency converters (FU)

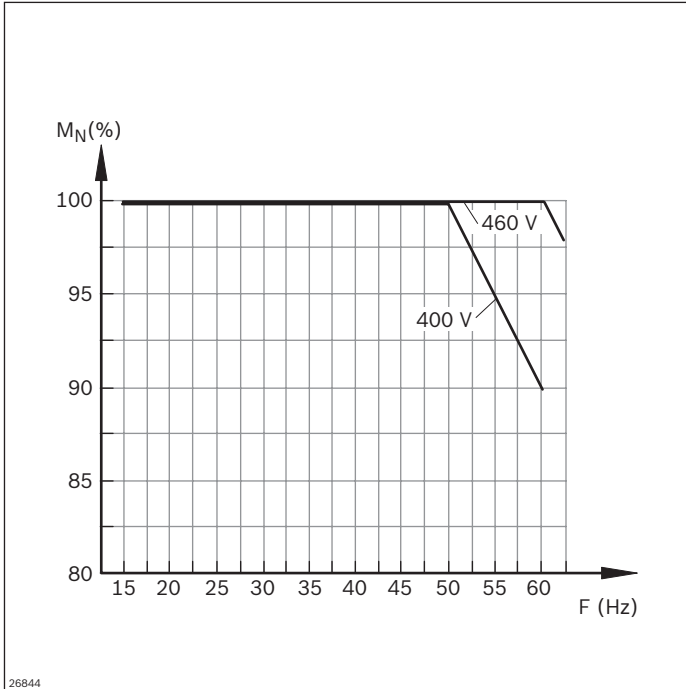

Technical information:

At rotating field frequencies of ≥ 15 Hz, the motor can be operated under normal operating conditions without an external fan. The motor's thermal conditions should be considered at rotating field frequencies of ≤ 20 Hz. At rotating field frequencies > 50 Hz, higher speeds can also be achieved with a corresponding drop in performance. In the range 20 ... 50 Hz, the full torque is available.

Base speed range of motor (m/min) at 50 Hz	Min ¹⁾ (m/min)	Max ²⁾ (m/min)	Max (m/min) at max. 80% torque
5 ³⁾	2	6	8
10 ³⁾	4	12	16
13	5	15	21
16	6	19	26
21	7	25	34
27	9	32	43
33	11	39	52
40	13	48	-
50	16	60	-

¹⁾ Min corresponds to approx. 16 Hz supply frequency

²⁾ Max corresponds to approx. 60 Hz supply frequency

³⁾ At 460 V/60 Hz max (m/min) 20% higher

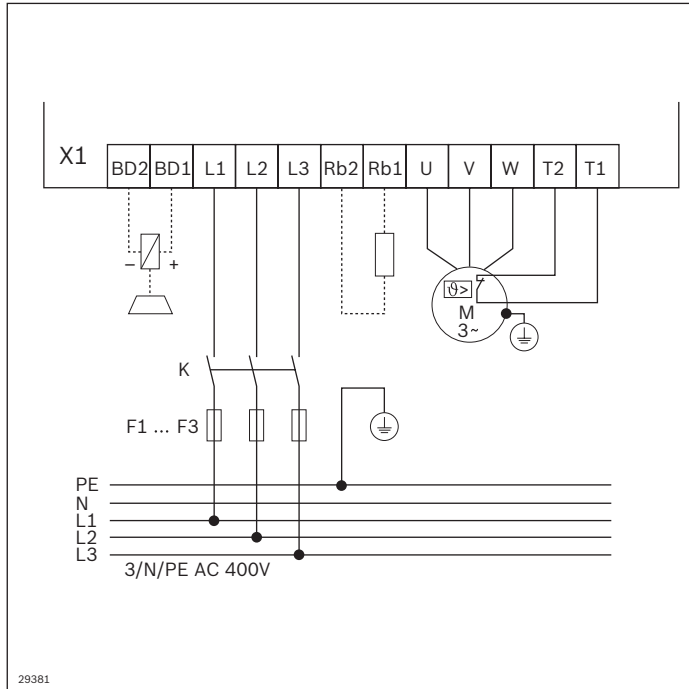

Frequency converter (FU) accessories

In order to operate a drive with a frequency converter (FU), the user needs to work out the minimum wiring for the internal and external voltage supply (see terminal assignment plan left).

- Minimum wiring required for operation
- *)---- Additional wiring to change rotational direction

Ordering parameters for SEW motors

The following ordering information is required if using gear motors from SEW-Eurodrive GmbH & Co, Bruchsal:

- Motor type
- Ratio
- Installation position
- Drive output position
- Terminal box position

- Cable entry (fig. 4)
- Motor voltage/frequency¹⁾
- Thermal class¹⁾
- Motor protection class¹⁾

¹⁾ www.seweurodrive.com

Motor data for SEW motors

v_N (m/min)	400 V / 50 Hz							Type SAF37...	400 V / 60 Hz						
	v (m/min)	i	n_1 (min ⁻¹)	n_2 (min ⁻¹)	M_N (Nm)	P (W)	v (m/min)		i	n_1 (min ⁻¹)	n_2 (min ⁻¹)	M_N (Nm)	P (W)	Type SAF37...	
2	2.07	122.94	1320	11	91	180	DR63M4	2.07	144.4	1620	11	92	180	DR63M4	
4	4.14	55.93	1300	22	81	250	DR63L4	4.14	71.44	1600	22	84	250	DR63L4	
6	6.03	43.68	1380	32	81	370	DRS71S4	6.03	53.83	1700	32	80	370	DRS71S4	
9	9.04	28.76	1380	48	75	370	DRS71S4	9.04	35.1	1700	48	75	370	DRS71S4	
12	11.49	22.5	1380	61	73	550	DRS71M4	11.12	28.76	1690	59	75	550	DRS71M4	
15	14.32	18.34	1380	76	52	550	DRS71M4	14.13	22.5	1690	75	73	550	DRS71M4	
18	19.41	13.39	1380	103	49	550	DRS71M4	17.53	18.24	1690	93	52	550	DRS71M4	
2 to 7¹⁾	1.5-7.53	35.1	280-1400	8.0-40	78	370	DRS71S4MM03	1.5-7.53	35.1	280-1400	8.0-40	78	370	DRS71S4MM03	
7 to 18¹⁾	3.95-19.79	13.39	280-1400	21-105	49	550	DRS71M4MM05	3.95-19.79	13.39	280-1400	21-105	49	550	DRS71M4MM05	

13

Motor data for SEW motors for HQ 5: b = 455

v_N (m/min)	400 V / 50 Hz							Type WAF10...	400 V / 60 Hz						
	v (m/min)	i	n_1 (min ⁻¹)	n_2 (min ⁻¹)	M_N (Nm)	P (W)	v (m/min)		i	n_1 (min ⁻¹)	n_2 (min ⁻¹)	M_N (Nm)	P (W)	Type WAF10...	
6	6.09	27.50	1300	47	12.0	90	DT56M4	6.34	32.50	1600	49	12.0	90	DT56M4	
9	8.59	19.50	1300	67	9.4	90	DT56M4	8.41	24.50	1600	65	9.4	90	DT56M4	
12	11.69	14.33	1300	91	7.6	90	DT56M4	12.49	16.50	1600	97	7.6	90	DT56M4	

Motor data for SEW motors for HQ 5: b = 650/845

v_N (m/min)	400 V / 50 Hz							Type WAF20...	400 V / 60 Hz						
	v (m/min)	i	n_1 (min ⁻¹)	n_2 (min ⁻¹)	M_N (Nm)	P (W)	v (m/min)		i	n_1 (min ⁻¹)	n_2 (min ⁻¹)	M_N (Nm)	P (W)	Type WAF20...	
6	6.18	27.50	1320	48	24.0	180	DR63M4	6.42	32.50	1620	50	24.0	180	DR63M4	
9	8.72	19.50	1320	68	19.0	180	DR63M4	8.52	24.50	1620	66	19.0	180	DR63M4	
12	11.86	14.33	1320	92	15.0	180	DR63M4	12.49	16.50	1600	97	15.0	250	DR63L4	

v = Transport speeds at other voltages/frequencies available on request

n_1 = Motor speed

n_2 = Gear output speed

P = Motor output

¹⁾ Controlled by a frequency converter (FU)

AS 5/XH, AS 5/H technical data:

Max. torque limit: 45 Nm (toothed belt) limited

Toothed belt drive gear ratio: 1:1

Flange \varnothing : 120 mm

Drive shaft: SW27 on shaft \varnothing 20

Conveyor rollers \varnothing : 60 mm

Motor installation position, terminal box, cable entry

Motor mounting	Installation position	Drive output	Terminal box
R	M2 (M1)	B	0°
L	M2 (M1)	A	180 °

Position of terminal box

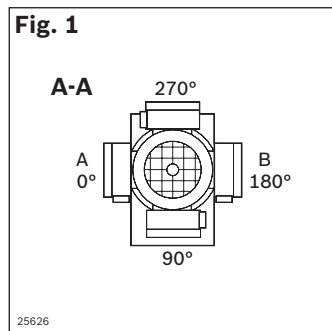

Installation position horizontal top/vertical

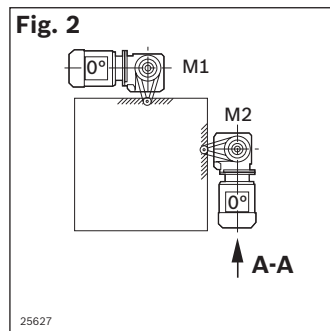

Installation position horizontal

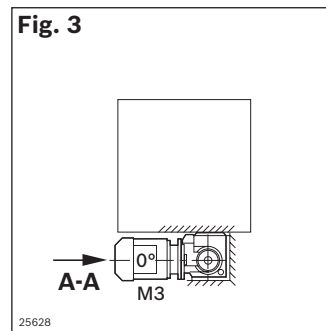

Cable entry point

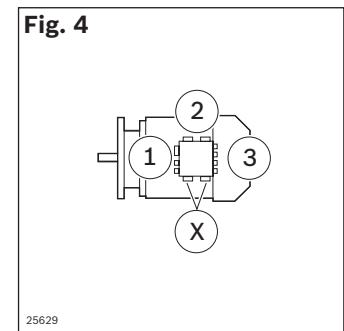

Conversion table for metric/imperial dimensions

Measurement	Multiply	by	to get:
Linear	millimeters (mm)	0.03937	inches
	inches	25.4	millimeters (mm)
	kilometers (km)	0.6214	miles
	miles	1.6093	kilometers (km)
Area	millimeters ² (mm ²)	0.00155	inches ²
	inches ²	645.16	millimeters ² (mm ²)
Volume	centimeters ³ (cm ³)	0.06102	inches ³
	inches ³	16.387	centimeters ³ (cm ³)
	1 cm ³ = 1 milliliter (ml)		
	1000 ml = 1 Liter		
Acceleration	meter/second ² (m/s ²)	39.37	inch/second ²
	inch/second ²	0.0254	meter/second ² (m/s ²)
Velocity	meter/second	3.281	feet/second
	feet/second	0.3048	meter/second
Mass	kilogram (kg)	2.2046	pounds
	pounds	0.4536	kilogram (kg)
Force	kilograms-f (kgf)	9.807	Newtons (N)
	Newtons (N)	0.10194	kilograms-f (kgf)
	pounds-f	4.448	Newtons (N)
Pressure	Newtons	0.2248	pounds-f
	bar	14.5	PSI
	PSI	0.069	bar
Torque	Newton meters (Nm)	8.851	pound inches
	pound inches	0.11298	Newton meters (Nm)
Moment of Inertia	centimeters ⁴ (cm ⁴)	0.02403	inches ⁴
	inches ⁴	41.623	centimeters ⁴ (cm ⁴)
Power	kilowatts (Kw)	1.34	horsepower (HP)
	horsepower (HP)	0.746	kilowatts (Kw)
Energy	Joules (J)	0.7376	foot/pounds (ft/lbs)
	foot/pounds (ft/lbs)	1.3558	Joules (J)

Metric Tap/Drill Specifications

Tap	Drill Size
M4 × 0.7	3.3 mm
M5 × 0.8	4.2 mm
M6 × 1	5.0 mm
M8 × 1.25	6.8 mm
M12 × 1.75	10.2 mm
M16 × 2	14.0 mm

Temperature

Degrees Celsius

$$5 \times (\text{degrees Fahrenheit} - 32) / 9$$



Degrees Fahrenheit

$$9 \times (\text{degrees Celsius}) + 32 / 5$$

Function plans

On the following pages, you can find proven fundamental function plans for control tasks in transfer systems.

Characters are used in the action blocks that deviate from DIN IEC 61131-3. They are explained in the following table.

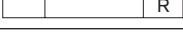
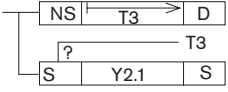
Action block	Explanation
	Storing
	Non-storing
	Set
	Reset
	Non-storing trigger of a time function (with runtime T), after which a switching function is triggered.

Simple stop gates VE 5 are used to stop the workpiece pallets. The position of the workpiece pallets is queried with separate sensors.

The function plans are simplified accordingly if using stop gates with integrated sensors and internal switching logic.

General abbreviations

- WT = Workpiece pallets
- VE = Stop gate
- S... = Signal transmitter
- Y... = Valve
- Z... = Cylinder
- LT = Longitudinal conveyor (main section)
- QT = Transverse conveyor (secondary section)
- HQ = Lift transverse unit
- DA = Damper
- ① = Start pulse after end of start-up
- ② = Enable cyclic travel

Function plans

Curve CU

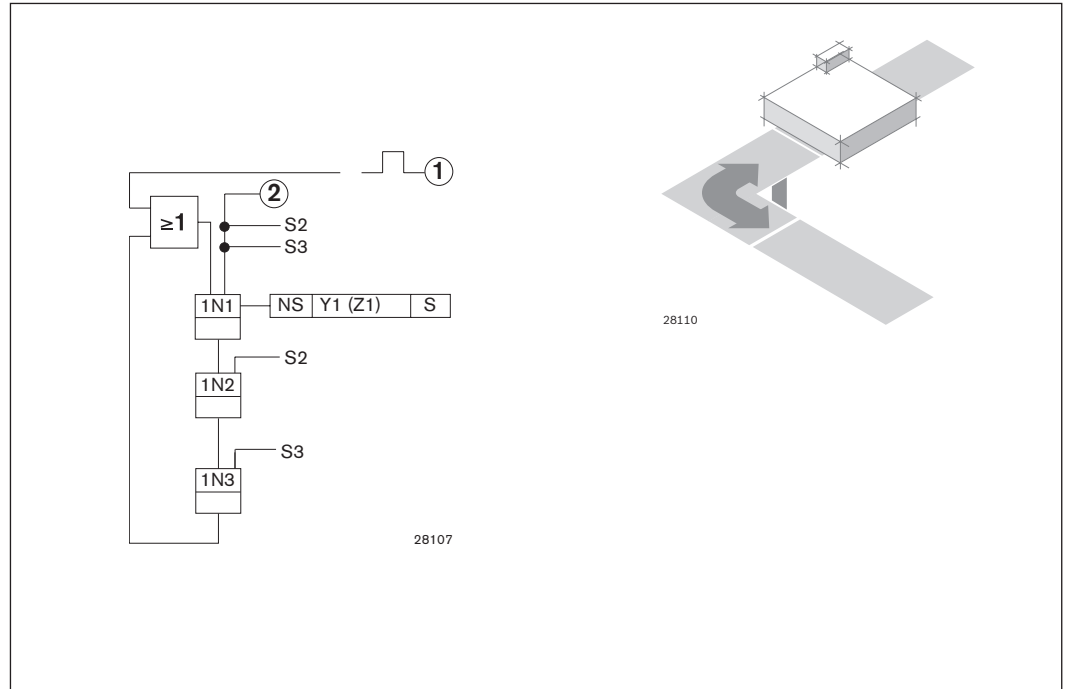
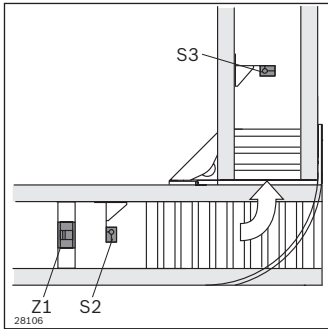

- S2 = WT after VE
- S3 = WT after CU
- Y1 = Open VE (Z1)

Function plans

Diverter DI

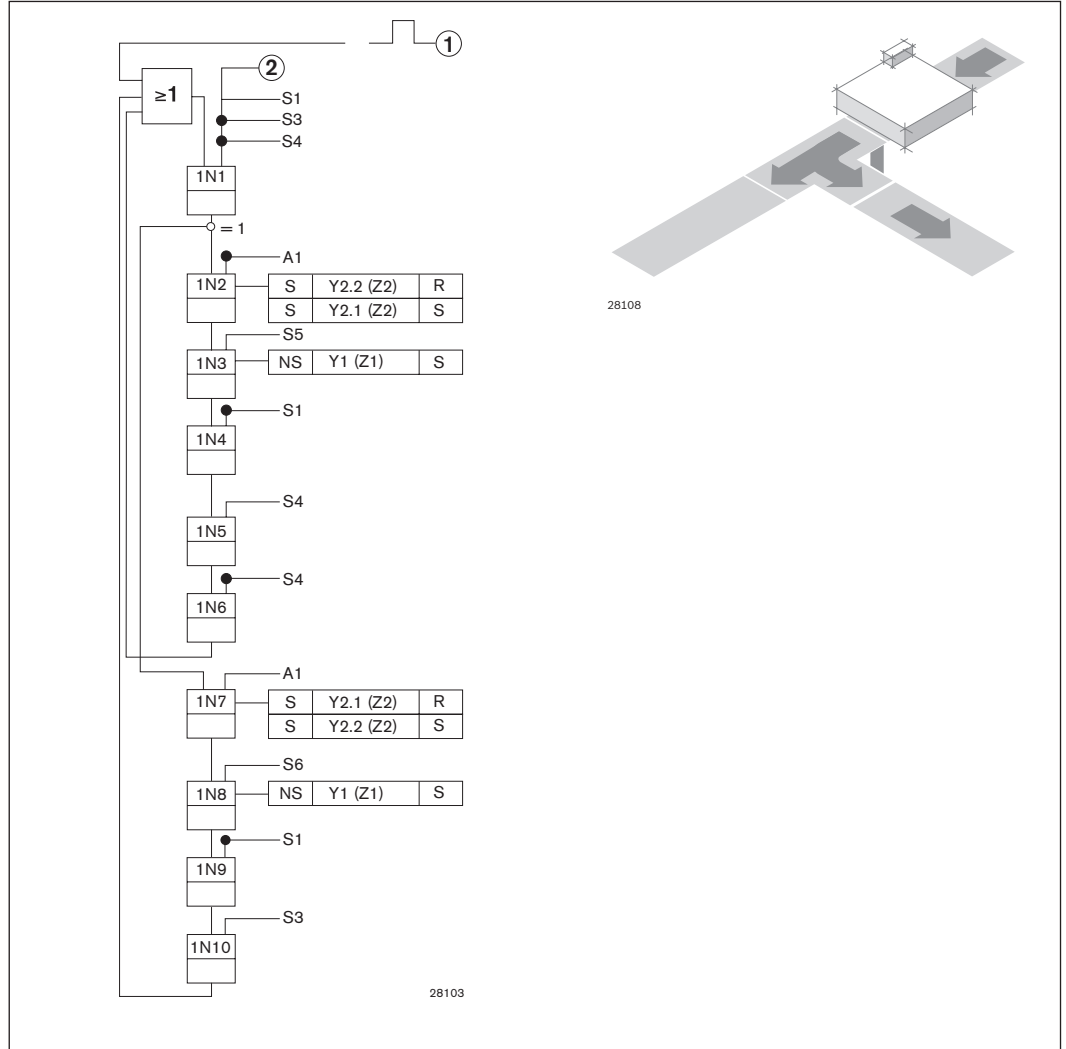
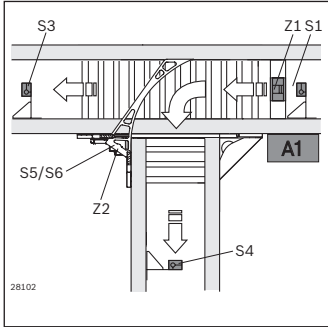

- S1 = WT at VE (Z1)
- S3 = WT behind main section diverter
- S4 = WT behind secondary section diverter
- S5 = Diverter open
- S6 = Diverter closed
- Y2 = Diverter (Z2)
- Y1 = Stop gate (Z1)
- A1 = Identification system with straight-ahead signal

Function plans

Junction JU

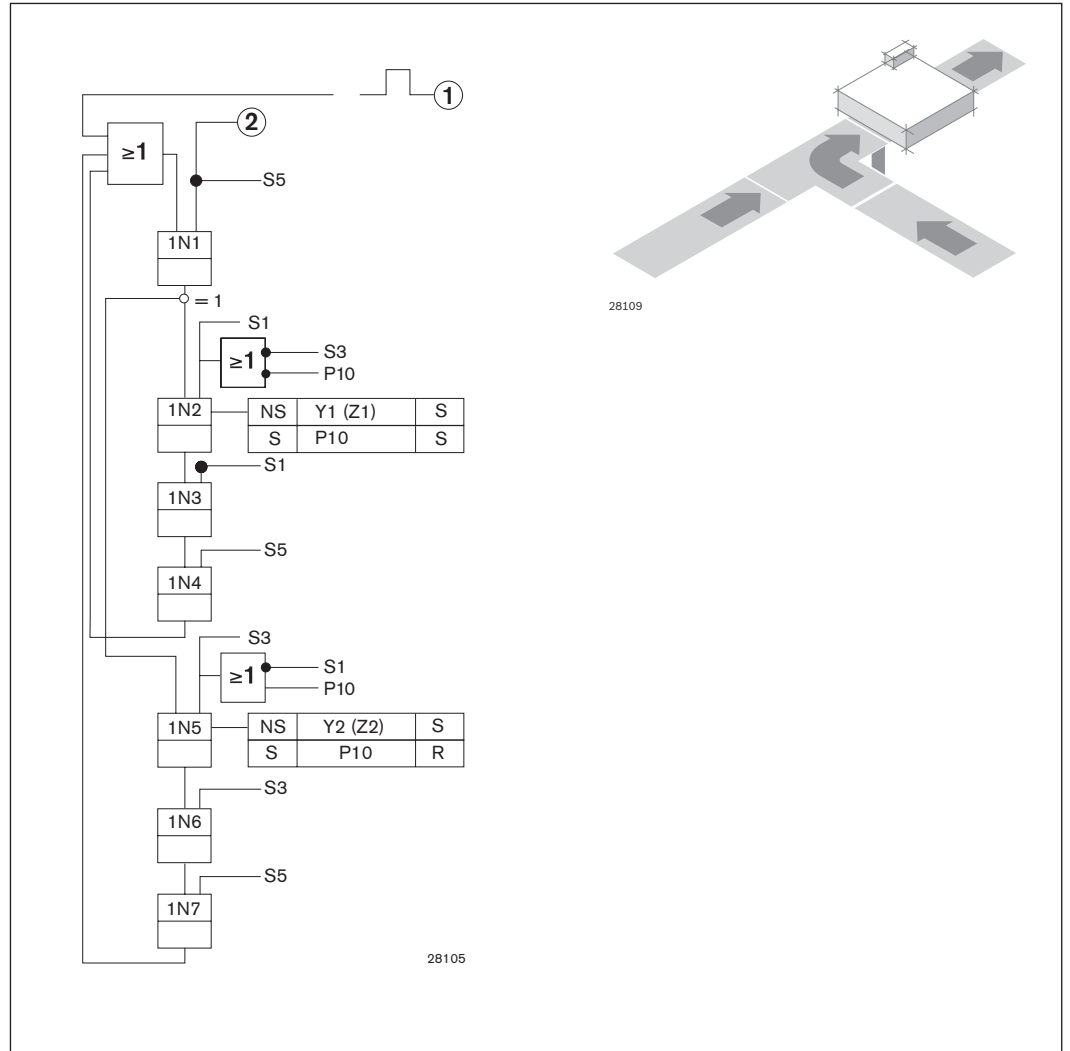
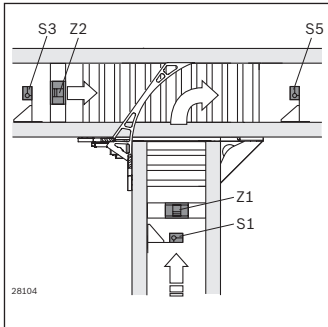

- S1 = WT at VE (Z1)
- S3 = WT at VE (Z2)
- Y1 = Secondary section VE (Z1)
- Y2 = Main section VE (Z2)
- P10 = Priority main section

Function plans

Three-way diverter

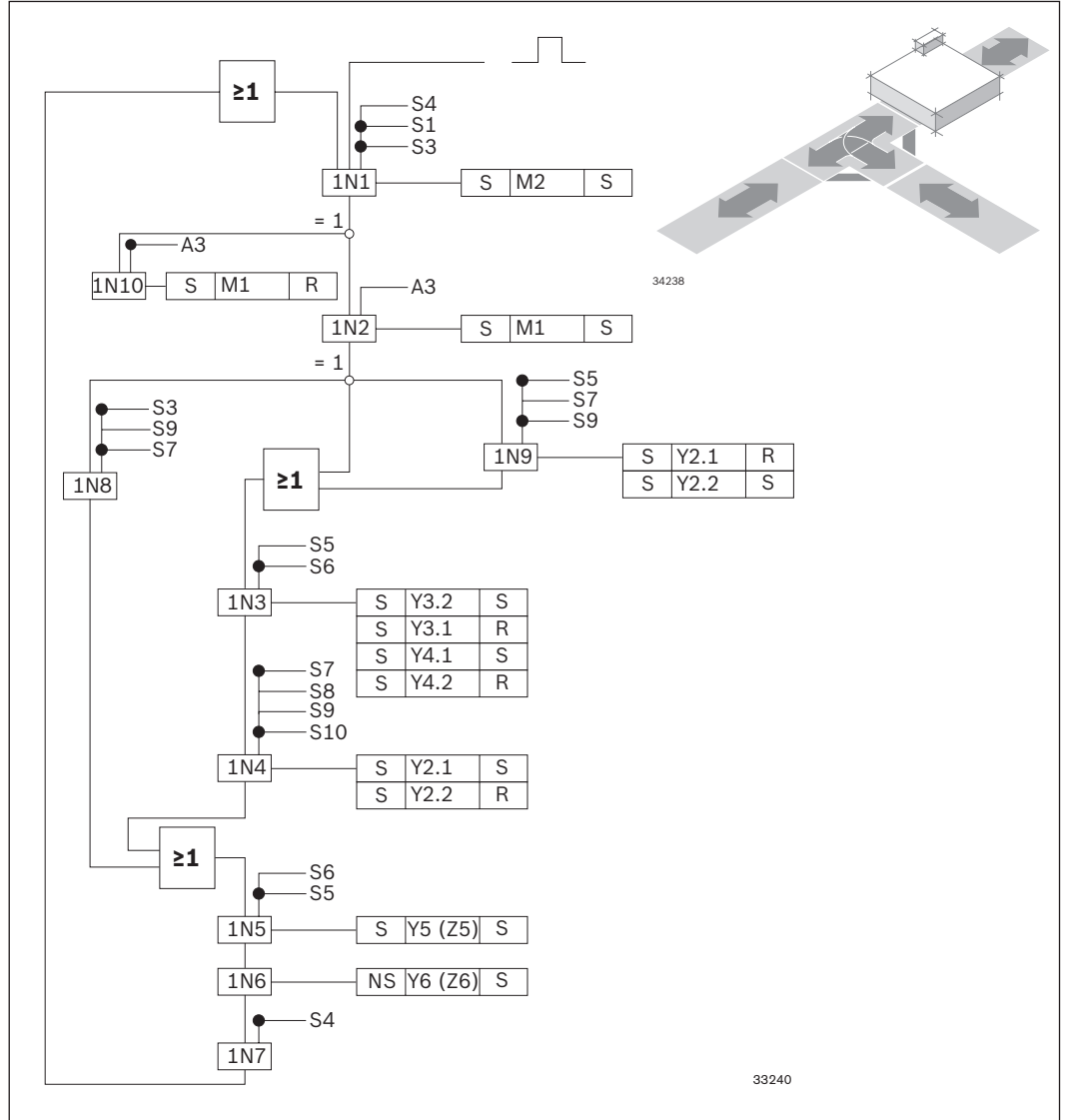
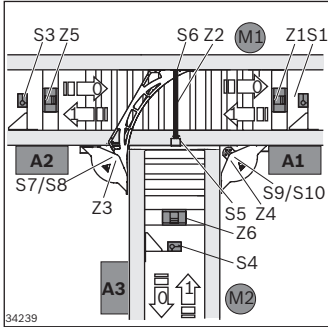

S5 = Diverter closed
 S6 = Diverter open
 S7 = Top
 S8 = Bottom
 S9 = Top
 S10 = Bottom
 A1/A2 = 0 = branch
 1 = straight on

A3 = 0 = right
 1 = left
 Y1, Y5, Y6 = Stop gate (Z1, Z5, Z6)
 Y2.1 = Open
 Y2.2 = Closed
 Y3.1 = Top
 Y3.2 = Bottom
 Y4.1 = Top

Y4.2 = Bottom
 M1 = 0 = right
 1 = left
 M2 = 0 = bottom
 1 = top

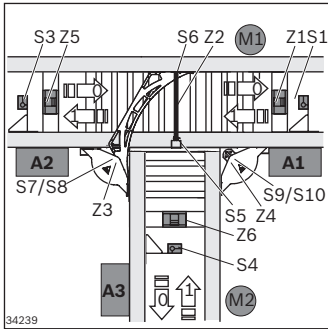

34239

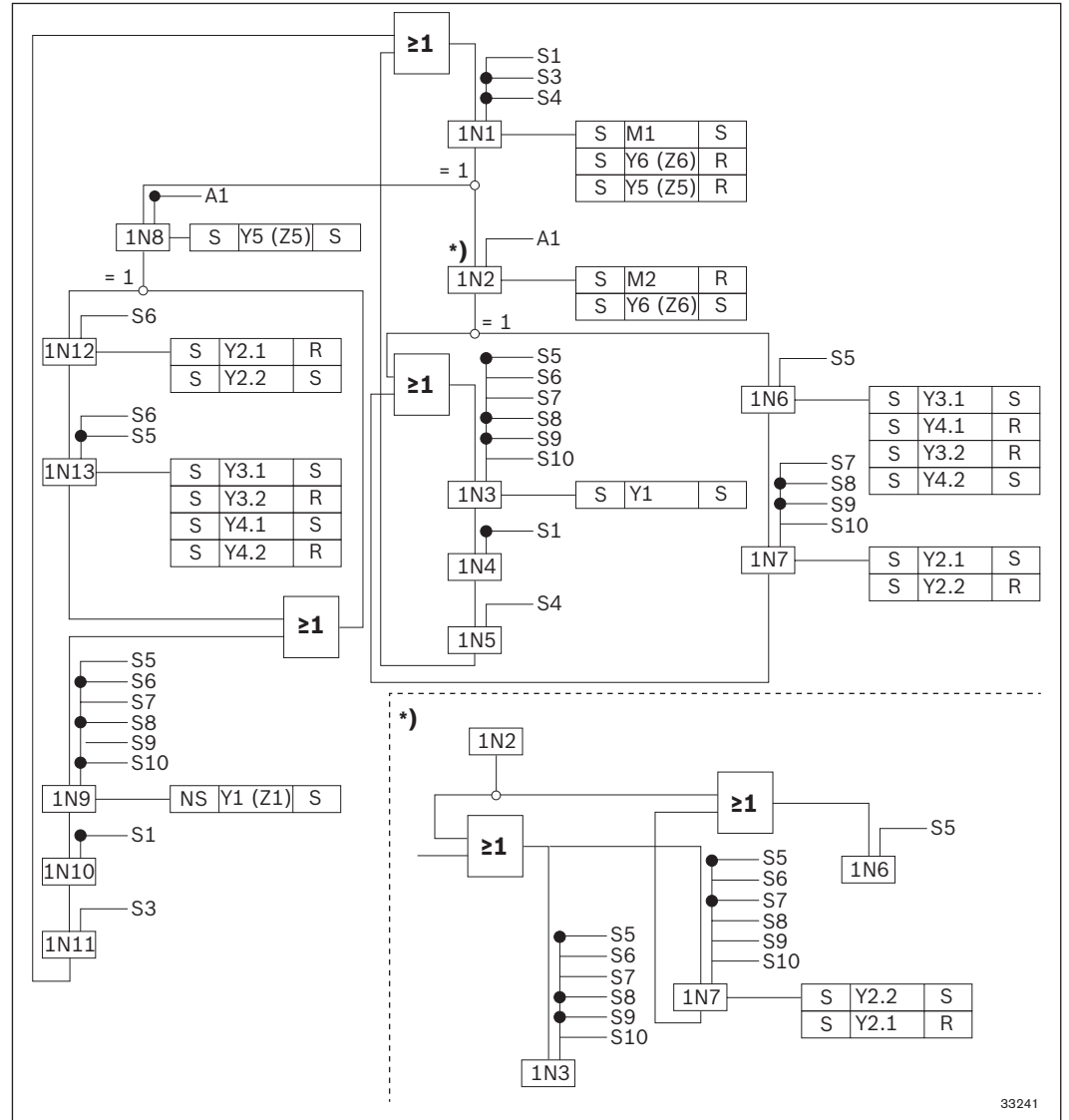

33241

* Optional kit

S5 = Diverter closed
 S6 = Diverter open
 S7 = Top
 S8 = Bottom
 S9 = Top
 S10 = Bottom
 A1/A2 = 0 = branch
 1 = straight on

A3 = 0 = right
 1 = left
 Y1, Y5, Y6 = Stop gate (Z1, Z5, Z6)
 Y2.1 = Open
 Y2.2 = Closed
 Y3.1 = Top
 Y3.2 = Bottom
 Y4.1 = Top

Y4.2 = Bottom
 M1 = 0 = right
 1 = left
 M2 = 0 = bottom
 1 = top

Function plans

Rotary unit

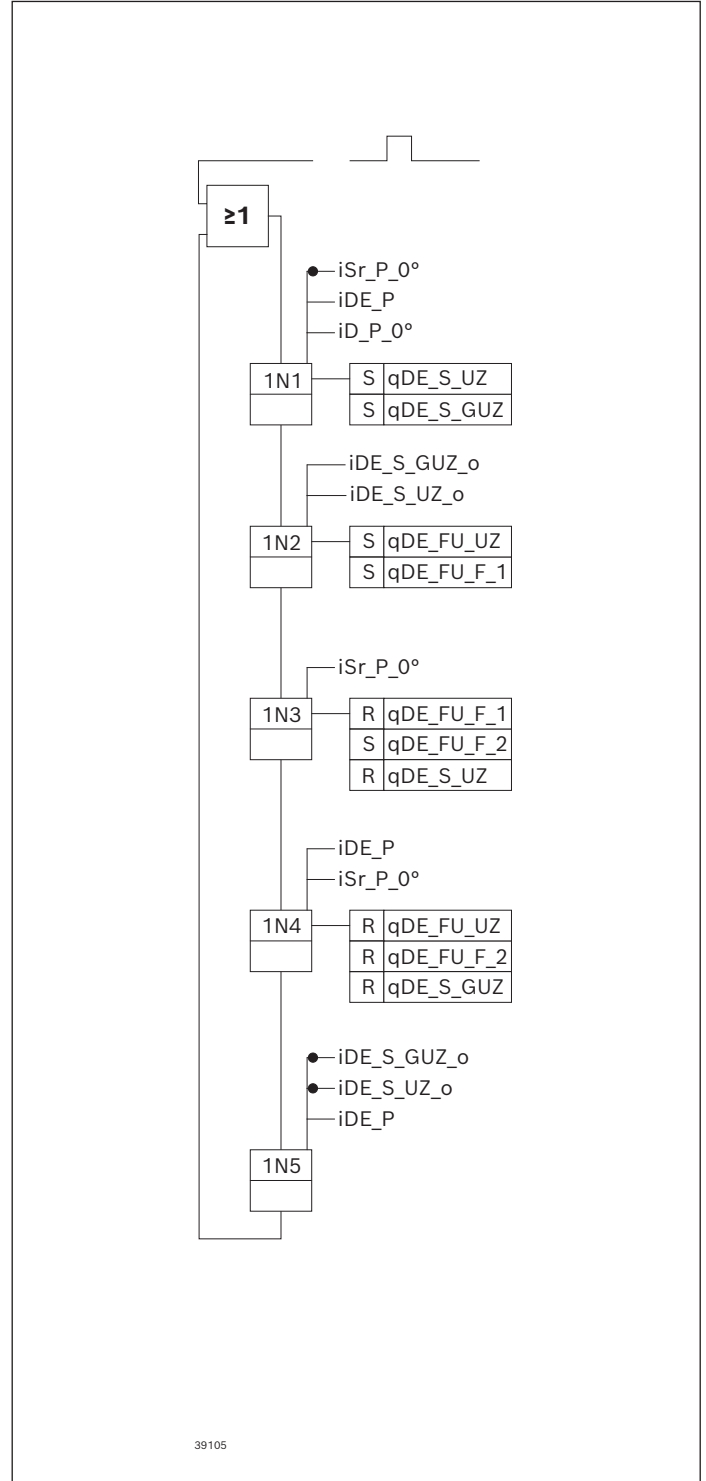
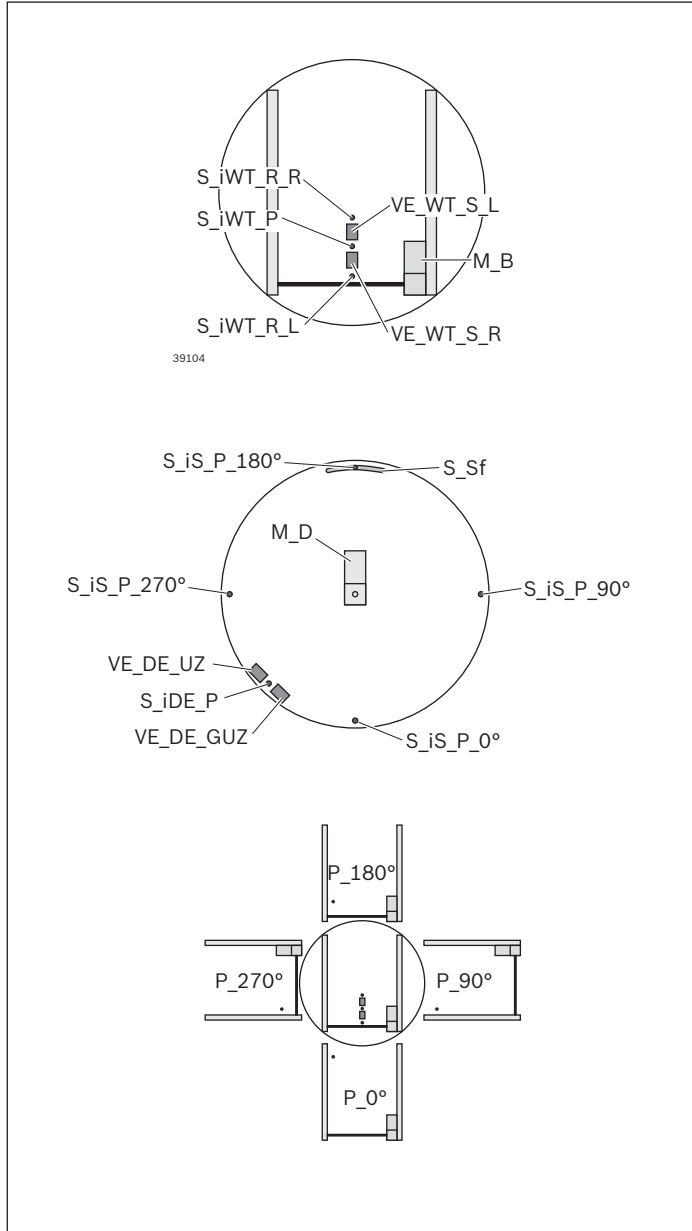

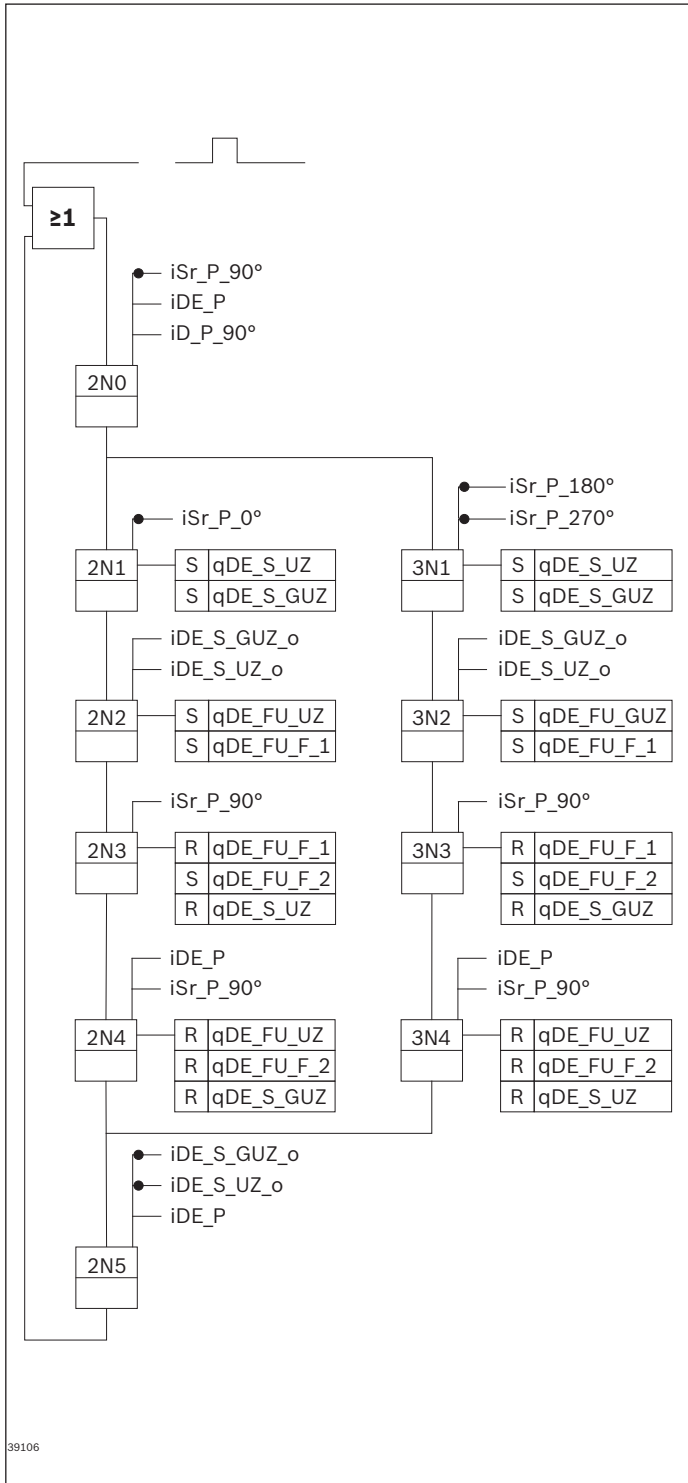

- iSr_P_0° = iStop ramp Pos 0
- iDE_P = iDE in Pos
- Id_P_0° = iRot to Pos 0
- iDE_S_GUZ_o = iDE stopper open in counter-clockwise direction
- iDE_S_UZ_o = iDE stopper open in clockwise direction
- iSr_P_90° = iStop ramp Pos 90
- Id_P_90° = iRot to Pos 90
- iSr_P_180° = iStop ramp Pos 180
- iSr_P_270° = iStop ramp Pos 270

Rotary unit

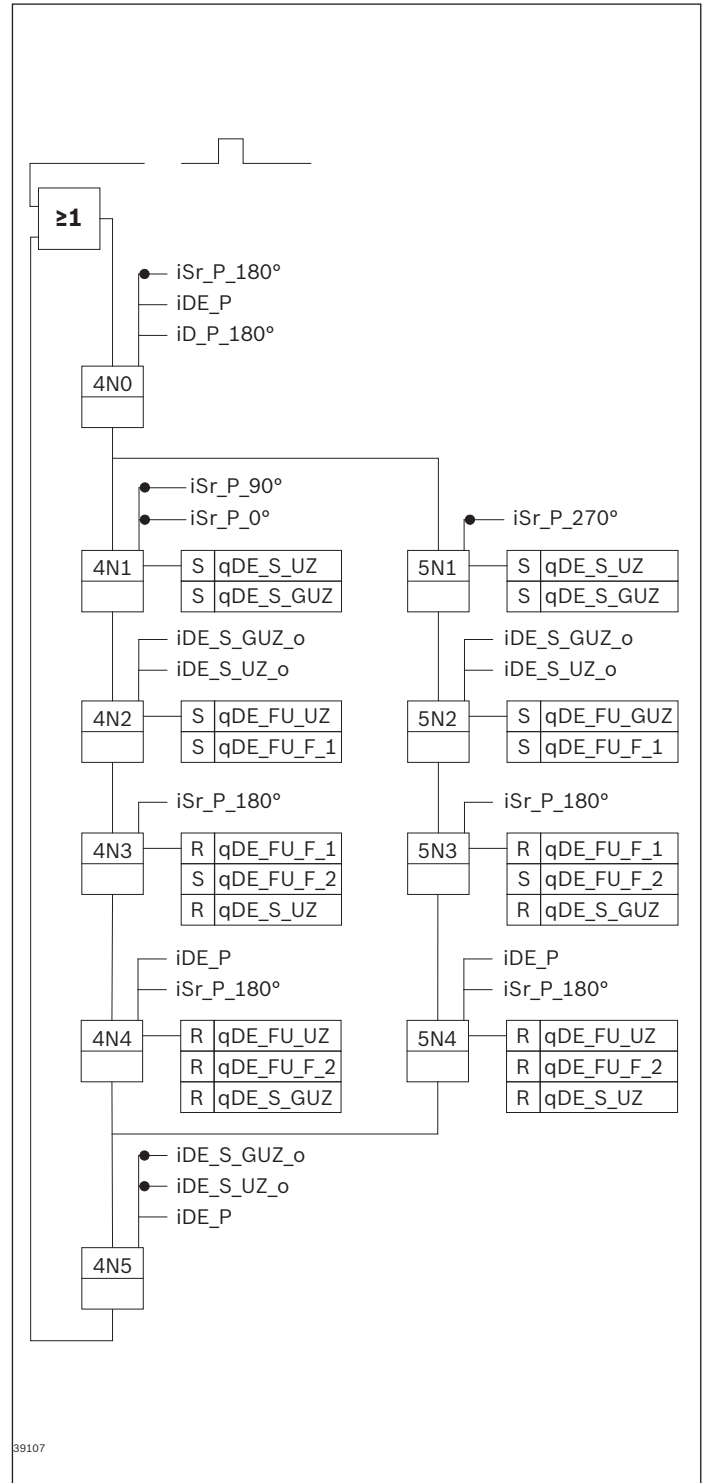
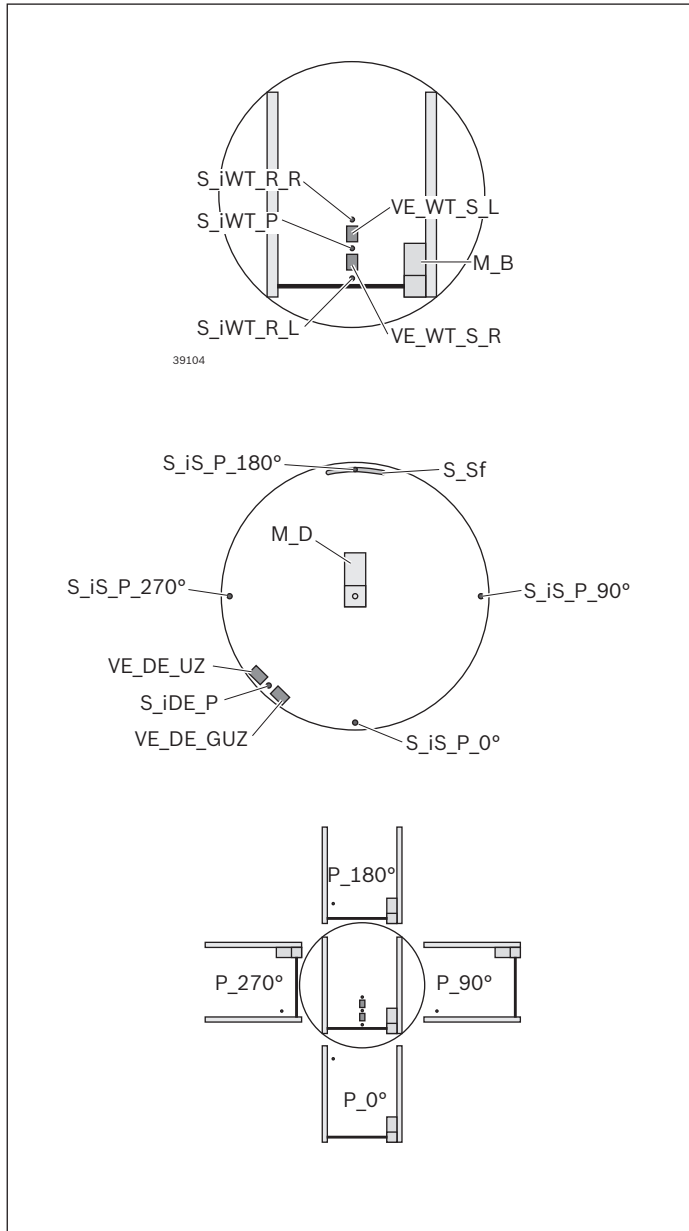

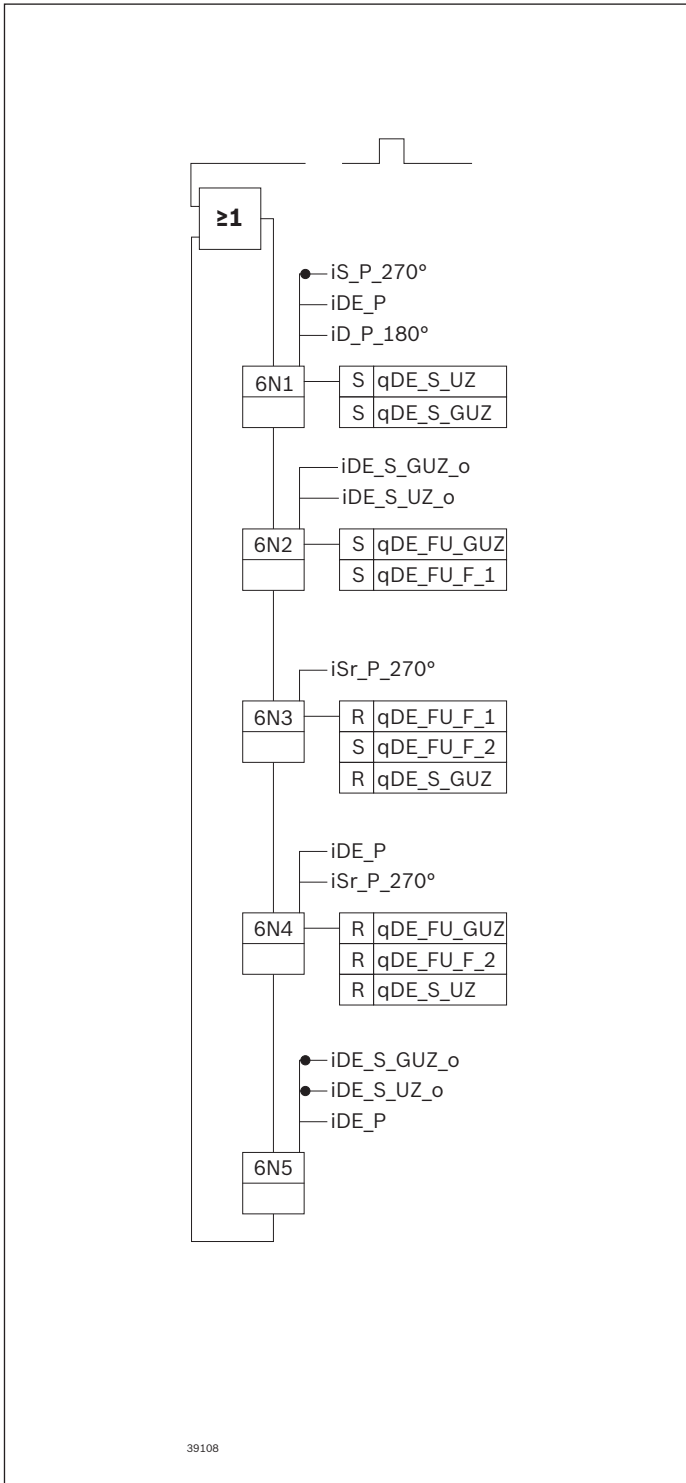

- iSr_P_0° = iStop ramp Pos 0
- iDE_P = iDE in Pos
- iDE_S_GUZ_o = iDE stopper open in counter-clockwise direction
- iDE_S_UZ_o = iDE stopper open in clockwise direction
- iSr_P_90° = iStop ramp Pos 90
- iSr_P_180° = iStop ramp Pos 180
- iSr_P_270° = iStop ramp Pos 270
- Id_P_180° = iRot to Pos 180

Function plans

Lift transverse unit HQ (stop gate, infeding)

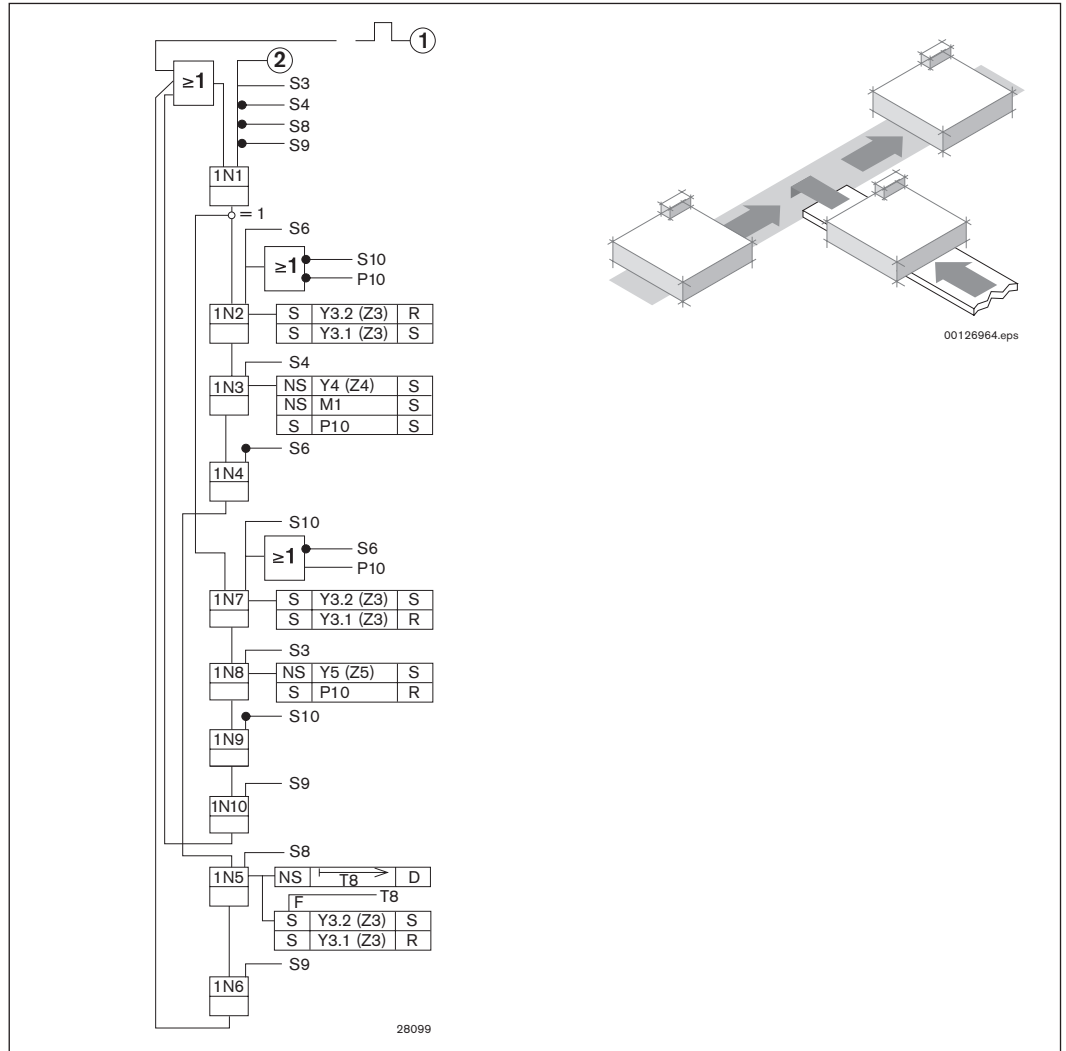
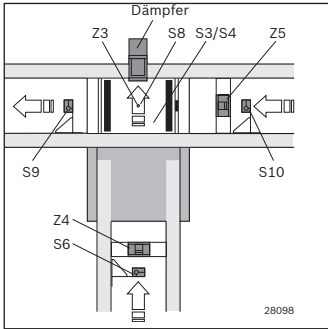

- | | | | | | |
|-----|---|-------------------------------|-----|---|--|
| T8 | = | Delaying time 100...200 ms | Y4 | = | Secondary section VE (Z4) + main section DA (Z6) |
| S3 | = | Lift end position at bottom | Y5 | = | Main section VE (Z5) |
| S4 | = | Lift end position at top | M1 | = | Motor HQ |
| S6 | = | WT before VE (Z4) | P10 | = | Priority main section |
| S8 | = | WT on HQ | | | |
| S9 | = | Enable main section 2 | | | |
| S10 | = | WT in front of stop gate (Z5) | | | |
| Y3 | = | Lift cylinder HQ (Z3) | | | |

Function plans

Lift transverse unit HQ (separating, outfeeding)

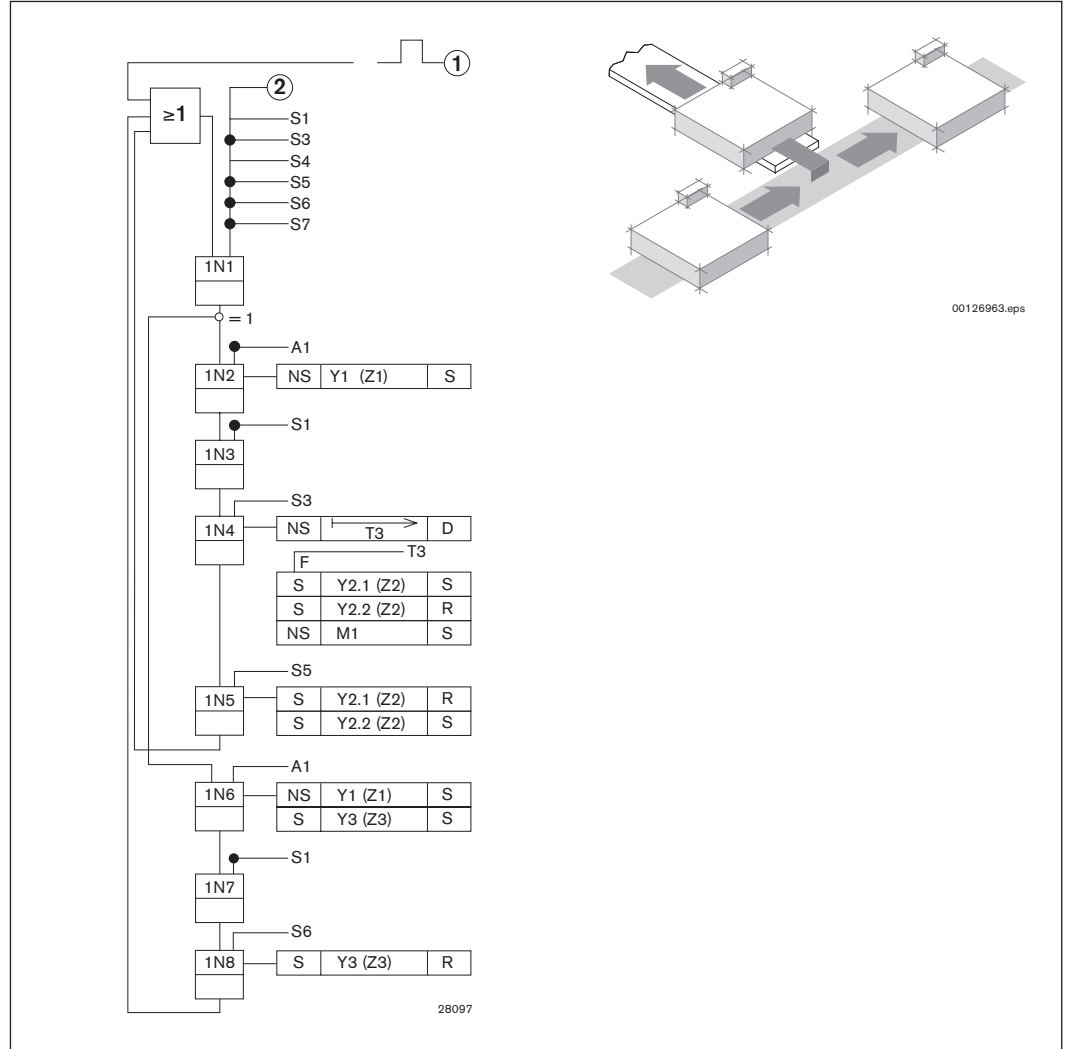
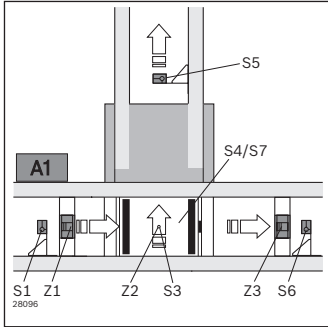

- T8 = Delaying time 100...200 ms
- S4 = Lift end position at bottom
- S7 = Lift end position at top
- S1 = WT before VE (Z1)
- S3 = WT on HQ
- S5 = Enable main section
- S6 = WT after stop gate (Z3)

- Y2 = Lift cylinder HQ (Z2)
- Y1 = Main section VE (Z1)
- Y3 = Main section VE (Z3)
- M1 = Motor HQ
- A1 = Identification system with straight ahead signal

Function plans

Positioning unit PE

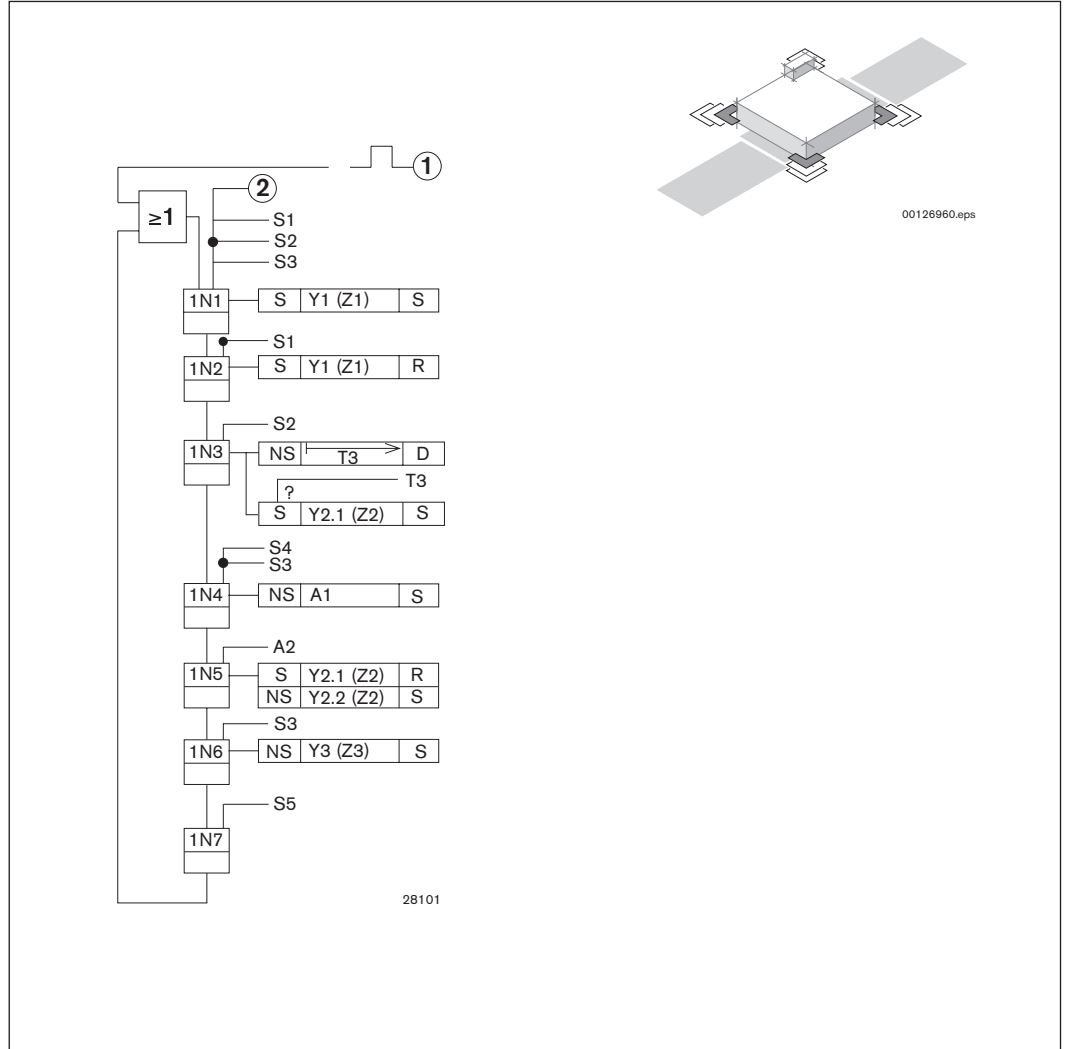
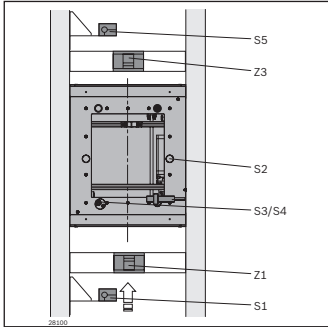

- S1 = WT before VE
- S2 = WT arrival
- S3 = Bottom end position of lift
- S4 = Top end position of lift
- S5 = WT after VE
- Y1 = Open VE (Z1)
- Y2 = WT lift (Z2)
- Y3 = Open VE (Z3)
- A1 = Start of processing
- A2 = End of processing

Compressed air consumption

Unit	Type	Diameter Ø (mm)	Lift (mm)	Volume*) (cm³)	Air consumption at 6 bar (l)
Positioning unit	PE 5	63	110	664	3.98
	PE 5/T				
	PE 5/OC				
	PE 5/OC-T				
	PE 5/L	4 x63	23	699	4.19
	PE 5/L-T				
Lift transverse unit	HQ 5	4 x63	13	513	3.08
	HQ 5/XH				
	HQ 5/H				
Stop gate	VE 5/200		15	43	0.26
	VE 5/D-300		15	95	0.57
	VE 5/D-301		30	103	0.62
	VE 5/D-1000		15	43	0.26
Diverter	DI 5/XH	25	47	42	0.25
	DI 5/H				
	DI 5/XH-3W (b=455)	16		105	0.63
	DI 5/H-3W (b=455)				
	DI 5/XH-3W (b=845)	16		152	0.91
	DI 5/H-3W (b=845)				
	DI 5/XH-3W (b=1040)	16		197	1.18
DI 5/H-3W (b=1040)					

*) Details on request

Material number overview

3 842 146 815	7-10	3 842 545 267	2-11	3 842 545 614	4-16	3 842 545 972	6-4, 6-7, 9-19, 9-20, 9-21
3 842 146 848	5-23, 5-27, 5-31, 7-3, 7-10	3 842 545 268	2-11	3 842 545 616	4-9	3 842 545 974	9-18
3 842 345 081	5-23, 5-27, 5-31, 6-23, 7-11, 8-24	3 842 545 269	2-11	3 842 545 617	4-9	3 842 545 975	6-17
3 842 410 102	10-2, 10-3, 10-4	3 842 545 270	2-11	3 842 545 619	4-9	3 842 548 863	7-6
3 842 503 845	4-7, 4-14	3 842 545 271	2-11	3 842 545 620	4-16	3 842 548 865	7-4, 7-8
3 842 511 783	4-7, 4-14, 4-21	3 842 545 276	4-7, 4-14	3 842 545 621	4-9	3 842 548 869	7-4, 7-6, 7-8
3 842 511 855	4-24	3 842 545 321	4-24	3 842 545 626	4-16	3 842 549 670	4-24
3 842 516 214	4-21	3 842 545 354	4-26	3 842 545 628	4-9	3 842 549 782	6-17
3 842 526 560	5-23, 5-27, 5-31, 7-3, 7-11	3 842 545 355	4-26	3 842 545 629	4-9	3 842 549 783	6-17
3 842 527 147	13-2	3 842 545 360	4-9, 6-21	3 842 545 630	4-16	3 842 549 784	6-17
3 842 528 715	7-11	3 842 545 361	4-9, 6-21	3 842 545 637	4-16	3 842 549 811	5-23, 5-27, 5-31, 9-3, 9-6, 9-12, 9-19, 9-20
3 842 528 718	5-23, 5-27, 5-31, 6-23, 7-11, 8-24	3 842 545 362	4-9, 6-21	3 842 545 638	4-9	3 842 549 812	5-23, 5-27, 5-31
3 842 528 746	4-25	3 842 545 363	4-9, 6-21	3 842 545 639	4-16	3 842 549 813	5-23, 5-27, 5-31, 9-19, 9-20
3 842 530 236	4-24	3 842 545 364	4-9	3 842 545 640	4-9	3 842 549 814	5-23, 5-27, 5-31, 9-3, 9-6, 9-12, 9-19, 9-20, 9-21
3 842 537 289	6-4, 6-7, 8-3, 8-9, 8-12, 8-15, 9-21, 9-22	3 842 545 365	4-9	3 842 545 641	4-9	3 842 551 761	5-23, 5-27, 5-31, 9-9, 9-19, 9-20, 9-21
3 842 539 057	12-3	3 842 545 403	4-9, 6-21	3 842 545 642	4-16	3 842 552 658	6-23
3 842 541 003	10-2	3 842 545 404	4-9, 6-21	3 842 545 643	4-16	3 842 552 659	6-23
3 842 541 004	10-2	3 842 545 404	4-9, 6-21	3 842 545 643	4-16	3 842 552 660	6-23
3 842 541 005	10-2	3 842 545 405	4-9, 6-21	3 842 545 644	4-9	3 842 552 661	6-23
3 842 541 006	10-2	3 842 545 406	4-16	3 842 545 645	4-9	3 842 552 662	6-23, 8-24
3 842 545 080	2-4	3 842 545 407	4-16	3 842 545 648	4-26	3 842 552 663	6-23, 8-24
3 842 545 081	2-11	3 842 545 408	4-16	3 842 545 659	4-14	3 842 552 664	6-23, 8-24
3 842 545 083	2-4	3 842 545 409	4-16	3 842 545 660	4-14	3 842 552 665	6-23, 8-24
3 842 545 084	2-11	3 842 545 410	4-16	3 842 545 661	4-14	3 842 552 672	9-7, 9-13, 9-16
3 842 545 086	2-4	3 842 545 411	4-16	3 842 545 662	4-14	3 842 552 821	3-35
3 842 545 087	2-11	3 842 545 412	4-16	3 842 545 663	4-14	3 842 553 184	3-35
3 842 545 089	2-4	3 842 545 413	4-16	3 842 545 664	4-14	3 842 553 445	3-34
3 842 545 090	2-11	3 842 545 414	4-16	3 842 545 665	4-14	3 842 553 447	3-33
3 842 545 092	2-4	3 842 545 415	4-16	3 842 545 666	4-14	3 842 553 449	3-33
3 842 545 093	2-11	3 842 545 416	4-16	3 842 545 667	4-14	3 842 553 450	3-33
3 842 545 095	2-4	3 842 545 417	4-14	3 842 545 668	4-14	3 842 553 451	3-33
3 842 545 096	2-11	3 842 545 418	4-14	3 842 545 669	4-14	3 842 553 452	3-33
3 842 545 128	6-15	3 842 545 419	4-14	3 842 545 670	4-14	3 842 553 453	3-33
3 842 545 130	6-15	3 842 545 420	4-14	3 842 545 671	4-14	3 842 553 454	3-33
3 842 545 132	8-3, 8-15, 9-24	3 842 545 421	4-7	3 842 545 672	4-14	3 842 553 457	3-34
3 842 545 134	9-24	3 842 545 422	4-7	3 842 545 673	4-14	3 842 553 459	3-33
3 842 545 144	10-3	3 842 545 423	4-7	3 842 545 674	4-14	3 842 553 512	3-34
3 842 545 150	4-24	3 842 545 424	4-7	3 842 545 675	4-14	3 842 554 557	8-26
3 842 545 151	4-24	3 842 545 425	4-7	3 842 545 676	4-14	3 842 554 558	8-26
3 842 545 152	4-24	3 842 545 426	4-7	3 842 545 677	4-14	3 842 554 559	8-26
3 842 545 153	4-24	3 842 545 427	4-7	3 842 545 678	4-14	3 842 554 560	8-26
3 842 545 154	4-24	3 842 545 428	4-7	3 842 545 679	4-7	3 842 554 561	8-26
3 842 545 155	4-24	3 842 545 429	4-7	3 842 545 680	4-7	3 842 554 562	8-26
3 842 545 156	4-24	3 842 545 430	4-7	3 842 545 681	4-7	3 842 554 569	8-26
3 842 545 157	4-24	3 842 545 431	4-7	3 842 545 682	4-7	3 842 554 570	8-26
3 842 545 158	4-24	3 842 545 432	4-7	3 842 545 683	4-7	3 842 554 571	8-26
3 842 545 160	4-26	3 842 545 433	4-7	3 842 545 684	4-7	3 842 554 572	8-26
3 842 545 214	4-7, 4-9, 4-14, 4-16, 4-21, 4-22, 4-24	3 842 545 434	4-7	3 842 545 685	4-7	3 842 554 573	8-26
3 842 545 215	4-26	3 842 545 435	4-7	3 842 545 686	4-7	3 842 554 574	8-26
3 842 545 216	4-26	3 842 545 436	4-7	3 842 545 687	4-7	3 842 554 931	2-6
3 842 545 217	4-26	3 842 545 437	4-7	3 842 545 688	4-7	3 842 554 932	2-6
3 842 545 218	4-26	3 842 545 438	4-7	3 842 545 689	4-7	3 842 557 633	5-23, 5-27, 5-31, 9-19, 9-21
3 842 545 248	4-24	3 842 545 439	4-7	3 842 545 690	4-7	3 842 557 663	9-20
3 842 545 264	2-6, 2-10, 2-12	3 842 545 440	4-7	3 842 545 691	4-7	3 842 558 990	9-19, 9-20, 9-21
3 842 545 266	2-11	3 842 545 441	4-7	3 842 545 692	4-7	3 842 559 589	3-25, 3-27, 4-21
		3 842 545 442	4-7	3 842 545 693	4-7		
		3 842 545 443	4-7	3 842 545 694	4-7		
		3 842 545 444	4-7	3 842 545 695	4-7		
		3 842 545 445	4-7	3 842 545 696	4-7		
		3 842 545 446	4-7	3 842 545 697	4-7		
		3 842 545 447	4-7	3 842 545 698	4-7		
		3 842 545 448	4-7	3 842 545 699	4-25		
		3 842 545 449	4-7	3 842 545 700	4-24		
		3 842 545 450	4-7	3 842 545 701	4-24		
		3 842 545 451	4-7	3 842 545 702	4-24		
		3 842 545 452	4-7	3 842 545 703	4-24		
		3 842 545 453	4-7	3 842 545 704	4-24		
		3 842 545 454	4-7	3 842 545 705	4-24		
		3 842 545 455	4-7	3 842 545 706	4-24		
		3 842 545 456	4-7	3 842 545 707	4-24		
		3 842 545 457	4-7	3 842 545 708	4-24		
		3 842 545 458	4-7	3 842 545 709	4-24		
		3 842 545 459	4-7	3 842 545 710	4-24		
		3 842 545 460	4-7	3 842 545 711	4-24		
		3 842 545 461	4-7	3 842 545 712	4-24		
		3 842 545 462	4-7	3 842 545 713	4-24		
		3 842 545 463	4-7	3 842 545 714	4-24		
		3 842 545 464	4-7	3 842 545 715	4-24		
		3 842 545 465	4-7	3 842 545 716	4-24		
		3 842 545 466	4-7	3 842 545 717	4-24		
		3 842 545 467	4-7	3 842 545 718	4-24		
		3 842 545 468	4-7	3 842 545 719	4-24		
		3 842 545 469	4-7	3 842 545 720	4-24		
		3 842 545 470	4-7	3 842 545 721	4-24		
		3 842 545 471	4-7	3 842 545 722	4-24		
		3 842 545 472	4-7	3 842 545 723	4-24		
		3 842 545 473	4-7	3 842 545 724	4-24		
		3 842 545 474	4-7	3 842 545 725	4-24		
		3 842 545 475	4-7	3 842 545 726	4-24		
		3 842 545 476	4-7	3 842 545 727	4-24		
		3 842 545 477	4-7	3 842 545 728	4-24		
		3 842 545 478	4-7	3 842 545 729	4-24		
		3 842 545 479	4-7	3 842 545 730	4-24		
		3 842 545 480	4-7	3 842 545 731	4-24		
		3 842 545 481	4-7	3 842 545 732	4-24		
		3 842 545 482	4-7	3 842 545 733	4-24		
		3 842 545 483	4-7	3 842 545 734	4-24		
		3 842 545 484	4-7	3 842 545 735	4-24		
		3 842 545 485	4-7	3 842 545 736	4-24		
		3 842 545 486	4-7	3 842 545 737	4-24		
		3 842 545 487	4-7	3 842 545 738	4-24		
		3 842 545 488	4-7	3 842 545 739	4-24		
		3 842 545 489	4-7	3 842 545 740	4-24		
		3 842 545 490	4-7	3 842 545 741	4-24		
		3 842 545 491	4-7	3 842 545 742	4-24		
		3 842 545 492	4-7	3 842 545 743	4-24		
		3 842 545 493	4-7	3 842 545 744	4-24		
		3 842 545 494	4-7	3 842 545 745	4-24		
		3 842 545 495	4-7	3 842 545 746	4-24		
		3 842 545 496	4-7	3 842 545 747	4-24		
		3 842 545 497	4-7	3 842 545 748	4-24		
		3 842 545 498	4-7	3 842 545 749	4-24		
		3 842 545 499	4-7	3 842 545 750	4-24		
		3 842 545 500	4-7	3 842 545 751	4-24		
		3 842 545 501	4-7	3 842 545 752	4-24		
		3 842 545 502	4-7	3 842 545 753	4-24		
		3 842 545 503	4-7	3 842 545 754	4-24		
		3 842 545 504	4-7	3 842 545 755	4-24		
		3 842 545 505	4-7	3 842 545 756	4-24		
		3 842 545 506	4-7	3 842 545 757	4-24		
		3 842 545 507	4-7	3 842 545 758	4-24		
		3 842 545 508	4-7	3 842 545 759	4-24		
		3 842 545 509	4-7	3 842 545 760	4-24		
		3 842 545 510	4-7	3 842 545 761	4-24		
		3 842 545 511	4-7	3 842 545 762	4-24		
		3 842 545 512	4-7	3 842 545 763	4-24		
		3 842 545 513	4-7	3 842 545 764	4-24		
		3 842 545 514	4-7	3 842 545 765	4-24		
		3 842 545 515	4-7	3 842 545 766	4-24		
		3 842 545 516	4-7	3 842 545 76			

3 842 559 590	3-25, 3-27, 4-21
3 842 562 895	3-28
3 842 563 978	3-25, 3-27, 4-7, 4-14, 4-21, 4-24
3 842 996 185	8-3, 8-5, 8-6, 8-8, 8-21
3 842 996 330	7-5
3 842 996 331	7-7
3 842 996 332	7-9
3 842 998 048	8-10, 9-21
3 842 998 049	8-13, 9-21
3 842 998 079	9-10, 9-21
3 842 998 080	9-10, 9-21
3 842 998 177	8-7, 9-21
3 842 998 178	8-16, 9-21
3 842 998 517	9-7, 9-21
3 842 998 518	9-4, 9-21
3 842 998 520	4-4
3 842 998 521	4-4
3 842 998 522	4-11
3 842 998 523	4-11
3 842 998 525	5-5
3 842 998 526	5-5
3 842 998 528	5-9, 9-21
3 842 998 529	5-9, 9-21
3 842 998 530	5-14
3 842 998 531	5-14
3 842 998 562	2-13
3 842 998 563	2-13
3 842 998 564	2-13
3 842 998 565	2-13
3 842 998 566	2-13
3 842 998 567	2-13
3 842 998 568	2-13
3 842 998 569	2-13
3 842 998 570	2-13
3 842 998 571	2-13
3 842 998 572	2-13
3 842 998 573	2-13
3 842 998 574	4-18
3 842 998 577	9-4, 9-21
3 842 998 578	9-7, 9-21
3 842 998 604	5-26, 5-30, 5-34, 6-19
3 842 998 605	5-26, 5-30, 5-34, 6-19
3 842 998 786	8-4, 9-21
3 842 998 804	8-19, 9-21
3 842 998 805	9-13, 9-21
3 842 998 806	9-13, 9-21
3 842 998 807	5-19, 9-21
3 842 998 808	5-19
3 842 998 837	3-5
3 842 998 838	3-5
3 842 998 839	3-10
3 842 998 840	3-10
3 842 998 841	3-15
3 842 998 842	3-22
3 842 998 862	5-28
3 842 998 863	5-24
3 842 998 864	5-32
3 842 998 924	9-15, 9-16
3 842 998 925	9-15, 9-16
3 842 998 928	6-8, 9-21
3 842 998 929	6-8, 9-21
3 842 998 930	6-5

Index

- ▶ **A**
 - Accessories
 - Frequency converter (FU) 3-35
 - Workpiece pallets 2-6
 - Ambient conditions 1-6
 - Assembly kit for PE 5 and PE 5/T 8-21
 - Assembly kit for switch bracket
 - SH 2/U-H 9-24
 - Assembly kits for ID 200
 - in Open Center sections 10-4
 - in the longitudinal conveyor 10-3
 - Attachment kit 2-6
- ▶ **B**
 - Base body 2-4
- ▶ **C**
 - Carrying plates
 - Standard sizes 2-10
 - Variable dimensions 2-12
 - Clamping holder for sensors 9-18
 - Compressed air consumption 13-29
 - Connection bridge 6-18
 - Connection kit AB 5 on CU 5 3-28
 - Connection kit for connecting
 - the transverse section 6-16
 - Connection kits
 - Coupling 4-25
 - Intermediate plates
 - for module transitions 4-26
 - Profile connector for
 - lateral guide 4-25
 - Profile connector for
 - section profile 4-25
 - Conversion table for
 - metric/imperial dimensions 13-15
 - Conveyor units
 - Selection 4-2
 - ST 5/OC (Open Center) 4-17
 - ST 5/XH-FR, ST 5/H-FR
 - (with full rollers) 4-10
 - ST 5/XH, ST 5/H
 - (with split rollers) 4-3
 - Coupling 4-26
 - Cover
 - for lateral guide of lift
 - transverse unit HQ 5 6-22
 - for transition OC/XH, OC/H 4-23
 - of lateral guide for
 - positioning units 8-24
 - Curves CU 5/XH, CU 5/H 5-4
 - Curves/diverters/rotary units
 - Curves CU 5/XH, CU 5/H 5-4
 - Design 5-2
 - Diverters DI 5/XH, DI 5/H 5-8
 - Junctions JU 5/XH, JU 5/H 5-13
 - Limits for the permissible
 - gravity center position
 - for junctions and diverters 5-17
 - Limits for the permissible gravity
 - center position
 - for the three-way diverter 5-22
 - Rotary unit DE 5 5-23
 - Rotary unit DE 5/FR 5-27
 - Rotary unit DE 5/OC 5-31
 - Three-way diverter
 - DI 5/XH-3W, DI 5/H-3W 5-18
 - ▶ **D**
 - Damper DA 5/200, DA 5/1000 6-14
 - Disassembly tool 11-2
 - Diverters DI 5/XH, DI 5/H 5-8
 - Dowel 7-10
 - Drive data 13-6
 - Drive kit AB 5 3-21
 - Drive layout 3-3
 - Drive options for an
 - Open Center section 3-19
 - Drive units
 - AS 5/OC (Open Center) 3-14
 - AS 5/XH, AS 5/H
 - (with split rollers) 3-4
 - AS 5/XH-FR, AS 5/H-FR
 - (with full rollers) 3-9
 - Connection kit AB 5 on CU 5 3-28
 - Design 3-2
 - Drive kit AB 5 3-21
 - Drive layout 3-3
 - Drive options for an
 - Open Center section 3-19
 - End plates for AB 5
 - with ST 5/OC 3-26
 - End plates for AB 5
 - with ST 5/XH, ST 5/H,
 - ST 5/XH-FR, ST 5/H-FR 3-24
 - Frequency converter (FU) 3-31
 - FU accessories 3-35
 - Selection of gear
 - motor GM on AB 5 3-30
 - Selection of gear motor
 - GM on AS 5 3-20
 - ▶ **E**
 - End plates
 - for AB 5 with ST 5/OC 3-26
 - for AB 5 with ST 5/XH, ST 5/H,
 - ST 5/XH-FR, ST 5/H-FR 3-24
 - for ST 5/OC 4-20
 - for ST 5/XH-FR, ST 5/H-FR 4-13
 - for ST 5/XH, ST 5/H 4-6
 - Energy efficiency – Rexroth 4EE 1-9
 - Explanation of parameters b
 - and IT 1-10
 - ▶ **F**
 - Foundation brackets, dowels 7-10
 - Frequency converter (FU) 3-31, 13-11
 - Attachment kit 3-34
 - Communication module 3-33
 - Connection cable 3-34
 - Connection unit 3-34
 - Frequency converters 3-33
 - FU accessories 3-35
 - Manual control unit 3-35
 - Switching/potentiometer unit 3-35
 - Function plans 13-16
 - Curve CU 13-17
 - Diverter DI 13-18
 - Junction JU 13-19
 - Lift transverse unit HQ
 - (separating, outfeeding) 13-27
 - Lift transverse unit HQ
 - (stop gate, infeeding) 13-26
 - Positioning unit PE 13-28
 - Rotary unit 13-22, 13-24
 - Three-way diverter 13-20
 - ▶ **I**
 - Identification systems 10-1, 10-2
 - Assembly kit in
 - Open Center sections 10-4
 - Assembly kit in the
 - longitudinal conveyor 10-3
 - Kits for installation
 - in workpiece pallet WT 5 10-5
 - Intermediate plates for
 - module transitions 4-26
 - ▶ **J**
 - Junctions JU 5/XH, JU 5/H 5-13
 - ▶ **K**
 - Kits for installation in
 - workpiece pallet WT 5 10-5
 - ▶ **L**
 - Layout design – selection
 - of modular units 1-11
 - Layout of the drive units 3-2
 - Leg set
 - SZ 5 7-4
 - SZ 5/OC 7-8
 - SZ 5/U 7-6
 - Leg sets
 - Design 7-1
 - Design 7-2

- Foundation brackets, dowels 7-10
- Leg set SZ 5 7-4
- Leg set SZ 5/OC 7-8
- Leg set SZ 5/U 7-6
- Lift transverse unit HQ 5 6-4
 - Connection bridge 6-18
 - Connection kit for connecting the transverse section 6-16
 - Cover for lateral guide of lift transverse unit HQ 5 6-22
 - Damper 6-14
 - Protective covers 6-20
- Limits for the permissible gravity center position
 - for junctions and diverters 5-17
 - for the three-way diverter 5-22
- Longitudinal conveyor 4-1
 - Connection kits 4-25
 - Conveyor units ST 5/OC (Open Center) 4-17
 - Conveyor units ST 5/XH-FR, ST 5/H-FR (with full rollers) 4-10
 - Conveyor units ST 5/XH, ST 5/H (with split rollers) 4-3
 - Cover for transition OC/XH, OC/H 4-23
 - End plates for ST 5/OC 4-20
 - End plates for ST 5/XH-FR, ST 5/H-FR 4-13
 - End plates for ST 5/XH, ST 5/H 4-6
 - Protective covers for ST 5/OC 4-22
 - Protective covers for ST 5/XH-FR, ST 5/H-FR 4-15
 - Protective covers for ST 5/XH, ST 5/H 4-8
 - Selection of conveyor units 4-2
- **M**
 - Material number overview 14-1
 - Motor connection 13-10
 - Motor data 13-7, 13-8
 - MTpro – Planning software 12-1, 12-3
- **O**
 - Open Center section
 - Drive options 3-19
 - Operating principle 1-3
 - Choice of system 1-3
 - Ordering parameters for SEW motors 13-13
- **P**
 - Permissible workpiece pallet load 2-8
 - Planning software, MTpro 12-1, 12-3
 - Positioning and orientation 8-1
 - Assembly kit for positioning unit PE 5 and PE 5/T 8-21
 - Cover of lateral guide for positioning units 8-24
 - Design 8-2
 - Positioning unit PE 5 8-3
 - Positioning unit PE 5/L 8-9
 - Positioning unit PE 5/L-T 8-12
 - Positioning unit PE 5/OC 8-15
 - Positioning unit PE 5/OC-T 8-18
 - Positioning unit PE 5/T 8-6
 - Protective covers for PE 5/OC and PE 5/OC-T 8-25
 - Protective sleeves for PE 5, PE 5/T, PE 5/L and PE 5/L-T 8-22
 - Positioning bushing set 2-6
 - Positioning unit
 - PE 5 8-3
 - PE 5/L 8-9
 - PE 5/L-T 8-12
 - PE 5/OC 8-15
 - PE 5/OC-T 8-18
 - PE 5/T 8-6
 - Profile connector 4-25
 - for lateral guide 4-25
 - for section profile 4-25
 - Protective covers
 - for lift transverse unit HQ 5 6-20
 - for PE 5/OC and PE 5/OC-T 8-25
 - for ST 5/OC 4-22
 - for ST 5/XH-FR, ST 5/H-FR 4-15
 - for ST 5/XH, ST 5/H 4-8
 - Protective sleeves for PE 5, PE 5/T, PE 5/L and PE 5/L-T 8-22
- **R**
 - Rotary unit 5-23
 - DE 5 5-23
 - DE 5/FR 5-27
 - DE 5/OC 5-31
- **S**
 - Selection 1-11
 - Conveyor units 4-2
 - Gear motor GM on AB 5 3-30
 - Gear motor GM on AS 5 3-20
 - of workpiece pallets in accordance with load limits 2-9
 - Workpiece pallets 2-2
 - Selection data 1-5
 - Sensor application matrix 9-21
 - Sensors with push-in fitting 9-19
 - M8x1 9-20
 - M12x1 9-20
 - M18x1 9-20
 - Sensor application matrix 9-21
 - Sensors with push-in fitting M8x1, M12x1 and M18x1 9-19
 - Stop gate
 - VE 5/200, VE 5/OC-200 9-3
 - VE 5/D-300, VE 5/OCD-300 9-6
 - VE 5/D-301, VE 5/OCD-301 9-9
 - Stop gate VE 5/D-1000-E, VE 5/OCD-1000-E 9-15
 - Stop gate VE 5/D-1000, VE 5/OCD-1000 9-12
 - Switch bracket SH 2/U-H 9-22
- Transverse conveyor 6-1
 - Connection bridge 6-18
 - Connection kit for connecting the transverse section 6-16
 - Cover for lateral guide of lift transverse unit HQ 5 6-22
 - Damper DA 5/200, DA 5/1000 6-14
 - Design 6-2
 - VE 5/D-1000, VE 5/OCD-1000 9-12
 - Switch bracket SH 2/U-H 9-22
 - System specifications 13-2
- **T**
 - Technical data 13-1
 - Compressed air consumption 13-29
 - Conversion table for metric/imperial dimensions 13-15
 - Drive data 13-6
 - Frequency converter (FU) 13-11
 - Function plans 13-16, 13-17, 13-18, 13-19, 13-20, 13-22, 13-26, 13-27, 13-28
 - Motor connection 13-10
 - Motor data 13-7, 13-8
 - Ordering parameters for SEW motors 13-13
 - System specifications 13-2
 - Transport and nominal speed 13-9
 - Three-way diverter DI 5/XH-3W, DI 5/H-3W 5-18
 - Tools 11-1
 - Disassembly tool 11-2
 - Transfer system TS 5 1-1
 - Ambient conditions 1-6
 - a premier-class roller conveyor 1-2
 - Energy efficiency – Rexroth 4EE1-9
 - Explanation of parameters b and IT 1-10
 - Layout design – selection of modular units 1-11
 - Operating principle 1-3
 - TS 5 features 1-5
 - Transport and nominal speed 13-9
 - Transportation control 9-1, 9-2
 - Assembly kit for switch bracket SH 2/U-H 9-24
 - Clamping holder for sensors 9-18
 - Sensors with push-in fitting M8x1, M12x1 and M18x1 9-19
 - Stop gate VE 5/200, VE 5/OC-200 9-3
 - Stop gate VE 5/D-300, VE 5/OCD-300 9-6
 - Stop gate VE 5/D-301, VE 5/OCD-301 9-9
 - Stop gate VE 5/D-1000-E, VE 5/OCD-1000-E 9-15
 - Stop gate VE 5/D-1000, VE 5/OCD-1000 9-12
 - Switch bracket SH 2/U-H 9-22

– Lift transverse unit HQ 5	6-4
– Protective covers for lift transverse unit HQ 5	6-20
TS 5 features	1-5
– Selection data	1-5

► W

Workpiece pallet load limits	2-9
Workpiece pallets	2-1
– Accessories	2-6
– Base body	2-4
– Carrying plates, standard sizes	2-10
– Carrying plates, variable dimensions	2-12
– Permissible load	2-8
– Selection	2-2
– Selection in accordance with load limits	2-9

Notes

Bosch Rexroth AG

Postfach 30 02 07
70442 Stuttgart, Germany
www.boschrexroth.com

Further information online:



Find your local contact person here:

<https://addresses.boschrexroth.com>



Rexroth media directory

Commercial media and technical documentation is available for download 24/7 at:
www.boschrexroth.com/mediadirectory



The data specified above only serves to describe the product. No statements concerning a certain condition or suitability for a certain application can be derived from our information. The information given does not exempt the user from the obligation of own judgment and verification. It must be remembered that our products are subject to a natural process of wear and aging.

3 842 540 380 (2021-09)
© Bosch Rexroth AG 2021
Subject to changes!